

Stewart-Amos

Owner's Manual



STEWART-AMOS

Sweeper Co.

GALAXY R6

SAFETY, OPERATION MAINTENANCE MANUAL



SN 3019 AND UP

LAST UPDATED FEBRUARY 2015





I. Table of Contents

General Safety Guideline	1
A. Safety Alert Symbols	13
B. Chassis Driver Safety Instructions	13
C. Operator Safety Instructions.....	14
D. Maintenance Safety Instructions.....	18
I. Warranty Information.....	21
II. Customer Assistance	23
III. General Sweeper System Description.....	24
A. Auxiliary Engine Shroud	25
B. Curb broom.....	26
C. Hopper	26
D. Hydraulic System	28
E. Lights, Flashers, Alarm	30
F. Spray Bar	31
G. Sweeping Hood.....	32
H. Water System	33
I. Dual Steering.....	34
J. Hand Hose.....	35
IV. SWEEPER STARTUP PROCEDURES AND OPERATION	36
A. Control panel	37
B. Bleeder Valve (Throttle Type Lever)	38
C. Auxiliary Engine Control System	39
D. Sweeping	40
A. E. Sweeping Condition Control	41
F. Gutter Broom Operation	42
G. Dust Suppression System	42
H. Shutting Down the Sweeper	44
I. Dumping the Hopper.....	45
J. Dual Steering.....	46
K. 12-VoLt Backup System.....	47

L. Rapid Reference Operating Outline	47
M. Recommended Operating Equipment.....	48
V. General Sweeper Maintenance Checks	49
A. Lubrication Maintenance Schedule	50
B. PERIODIC MAINTENANCE SCHEDULES.....	51
B1. DAILY MAINTENANCE	Error! Bookmark not defined.
B2. WEEKLY MAINTENANCE (EVERY 40 HOURS OF OPERATION)	53
C. COMPONENT MAINTENANCE PROCEDURES	54
C1. CLEARING OBSTRUCTIONS FROM THE INLET TUBE	54
C2. CLEANING MAINTENANCE	55
C3. STORAGE MAINTENANCE	55
C4. AUXILIARY ENGINE MAINTENANCE	56
C5. BOLT CHECK MAINTENANCE.....	61
C6. CURB BROOM MAINTENANCE.....	62
C7. Drive Train Maintenance	69
C8. Fan Housing Maintenance	72
C9. SEAL MAINTENANCE.....	81
C10. SWEEPER ENGINE/FAN RPM CHECK.....	82
C11. SWEEPER FLUID MAINTENANCE.....	83
C12. SWEEPER FILTER MAINTENANCE.....	84
C13. SWEEPING HOOD MAINTENANCE	85
C14. Water system Maintenance	89
VI. Troubleshooting.....	92
A. MISCELLANEOUS.....	92
B. SWEEPING HOOD.....	95
C. GUTTER BROOM	95
D. HYDRAULIC SYSTEM.....	99
E. WATER SYSTEM.....	100
PARTS MANUAL.....	102
MAINFRAME	104
POWER MODULE.....	106



ENGINE SKID.....	108
HYDRANT FILL TUBE.....	110
MANIFOLD.....	111
HOSES SCHEMATIC.....	112
HYDRAULIC RESERVOIR.....	114
FAN HOUSING	116
FAN LINER KIT.....	117
COMPLETE HOPPER	118
HOPPER	120
TOP DOOR.....	122
INSPECTION DOOR.....	123
DUMP DOOR	124
LIGHT BAR	126
PICKUP FLAPS.....	127
PICKUP HEAD	128
REAR BUMPER.....	130
TOOL BOX.....	131
SHROUD	132
GUTTER BROOM UPPER SECTION.....	134
GUTTER BROOM UNDER SECTION.....	136
WATER SYSTEM.....	138
ENGINE CONTROL BOX	140
SWEEPER CONTROL PANEL.....	142
CAB PANEL MOUNTING	144
AUXILIARY CONTROL BOX.....	145
AUXILIARY CONTROL BOX SCHEMATIC.....	146
VALVE HARNESS.....	147
BODY HARNESS	148
SWITCH BOX HARNESS.....	149
BUMPER HARNESS	150
TOP MARKER HARNESS.....	151



TOP BEACON HARNESS	152
HAND HOSE.....	154
R-6 DECAL CHART.....	157
INDEX BY PAGE.....	173
INDEX BY PART#.....	179

General Safety Guideline

Safety is always of prime importance when operating any type of machine or vehicle in the vicinity of people. All persons working with this unit are to be knowledgeable of the safety practices and features detailed in this section.

Safety Is a Shared Responsibility

Safety is everyone's responsibility. Working together with Safety as the prime objective will insure a safe work environment and reduce injuries.

The operator must become familiar with safe operating procedures and use the equipment in the fashion that it was intended. Routine inspections and maintenance will prevent premature wear, expensive downtime and ensure that the equipment functions as it is intended.

Recognize Safety Information

This is the safety alert symbol. When you see this symbol in the manual or on your machine, be alert to the potential for personal injury.

DANGER: Identifies the most serious hazard

WARNING: identifies a potential hazard if safety precautions are not take

CAUTION: Identifies a general safety precaution



Equipment Lockout

It is strongly recommended that a commonly known Equipment Lockout procedure be enforced at your work environment. This is a series of precautions designed to protect any personnel that is inspecting, cleaning, or repairing the equipment. The Lockout Procedure should include the following.

1. Apply Parking Brake.
2. Place hopper, hopper door in secure positions so that they cannot accidentally fall. If required, install additional blocking devices such as hopper safety pins.
3. Turn off Auxiliary Engine.
4. With auxiliary engine off, turn key to run position and work hydraulic functions to relieve any residual pressure in the hydraulic system.
5. Remove keys from ignition.
6. Store keys in pocket or in a safe controlled area.
7. Place an "OUT OF SERVICE" sign on the steering wheel using a non-reusable fastener.
8. Place an "OUT OF SERVICE" sign on the front window.
9. Disconnect negative terminal from battery.

Hopper Port Restrictors

To control the decent of the hopper under all conditions port restrictors are used in the hopper lift cylinders. These port restrictors are sized to give a controlled decent of the hopper even if a hydraulic hose would rupture with a full hopper at the top of its travel. The hopper would come back to the at rest position with minimal damage to the equipment.

DANGER: Do not remove or modify any port restrictors





General Safety Precautions

Before Operating Machine

1. Read the operators manual and the engine manual to familiarize yourself with safe operating practices before operating the machine.
2. Read the chassis operator's manual thoroughly to familiarize yourself with safe operating practices before operating machine.
3. Be sure all observers are clear of the machine and at a safe distance.
4. Ensure mirrors, windows, lights, and monitor equipment (if equipped), are clean and adjusted properly at all times.
5. Do not enter hopper unless engine is shut off, key is removed and there is a note posted indicating not to start the engine. (See Equipment Lockout).

When Operating Machine

1. Operate controls from the operator's station only.
2. Keep all riders off the machine.
3. Keep all safety shields in place.
4. Ensure the area is clear of any persons or possible obstructions.
5. Do not wear loose clothing or jewelry.
6. Do not leave the vehicle before it is brought to a complete stop and the parking brake is applied.
7. Be cautious while driving with an unevenly distributed load.
8. Inspect for overhead hazards (e.g. power lines) before raising the hopper.
9. Raise the hopper only on level ground.
10. Ensure the hopper has completely lowered and the hopper door is closed before moving the vehicle. Do not move vehicle with hopper up.
11. Do not stand under the hopper when it is in the dump position.

When Servicing Machine

1. Follow the Equipment Lockout procedure described above.
2. Install safety pins into holes in slide frame to prevent scissor frame from moving when servicing under the hopper. (See Safety Features).
3. Never work under a loaded hopper even with safety pins installed.

Safety Features

This machine is equipped with many safety features. To operate this equipment safely, it is imperative to be aware of these functions. Please read all of the features listed, as the order they are presented does not reflect the degree of importance. Some safety features listed are options and MAY or MAY NOT be on your unit.

If there are concerns, report to your supervisor or maintenance department.

1. Decals - These must be clean and visible at all times.
2. Mirrors - A variety of mirrors, including large convex ones, are to help ensure adequate rear vision. These must be properly adjusted, clean and visible at all times!
3. Cameras – All machines are equipped with side and rear cameras, if so equipped, they must be in proper working order at all times. The rear camera option is also wired to the chassis transmission, when the chassis is shifted into reverse the rear camera will automatically activate and will go off automatically when chassis is shifted out of reverse.
4. Marker Lights - There is 1 marker lamp on each side of the sweeper and an ID bar at the back on the elevator cover. Marker lights are wired direct to chassis lights and come on with chassis lights.
5. Beacon and/or Strobe Lights - The switch is installed in the sweeper control box inside the cab. The lights are mounted on the front and rear canopy of sweeper.
6. Gutter Broom Lights - These lights are used for work lights and are mounted at both gutter brooms. The switch is found on the control box in the cab.
7. Main Broom Light - This light is used for a work light and is mounted on the drivers side at the back above the main broom. The switch for this work light is combined with the gutter broom light switch in the 3rd position.
8. Backup Alarm - When the truck is put into reverse this alarm sounds. The alarm is mounted to the rear canopy frame.
9. Hopper Safety Prop - If any work is to be done under a lifted hopper, insert props into the main frame roller rails. This will restrict any movement of the scissors frame sliders, thus keeping the hopper stable. **NEVER** use the safety pins to hold a **LOADED HOPPER!**
10. Arrow Board (option) - A separate control box mounted in the cab controls the arrow board mounted on the rear of the sweeper. A switch and pattern selector with indicator lights controls the order the light pattern.
11. Fire Extinguisher (option) - This is located in the cab behind the driver's seat.
12. First Aid Kit (option) - This is located inside the cab behind the driver's seat.

FOLLOW SAFETY INSTRUCTIONS

Carefully read all safety messages in this manual and on your machine safety signs.

Keep safety signs in good condition. Replace missing or damaged safety signs. Be sure new equipment components and repair parts include the current safety signs. Replacement safety signs are available from your dealer.



Learn how to operate the machine and how to use controls properly. Do not let anyone operate without instruction.

Keep your machine in proper working condition. Unauthorized modifications to the machine may impair the function and/or safety and affect machine life.



If you do not understand any part of this manual and need assistance, contact your dealer.

PREVENT BYPASS STARTING

Do not start engine by shorting across starter terminal.

Start engines only from operator's station with transmission in park.



HANDLE FUEL SAFELY-AVOID FIRES

Handle fuel with care: It is highly flammable. Do not refuel the machine while smoking or when near open flame or sparks.

Always stop engine before refueling machine. Fill fuel tank outdoors.

Prevent fires by keeping machine clean of accumulated trash, grease, and debris. Always clean up spilled fuel.

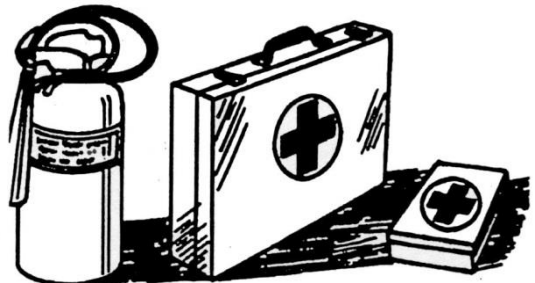

PREPARE FOR EMERGENCIES

Be prepared if a fire starts.

Keep a first aid kit and fire extinguisher handy.

Keep emergency numbers for doctors, ambulance service, hospital, and fire department near your telephone.



NEVER USE STARTING FLUID

Starting fluid is highly flammable and can cause serious damage to engines.

WEAR PROTECTIVE CLOTHING

Wear close fitting clothing and safety equipment appropriate to the job.

Operating equipment safely requires the full attention of the operator. Do not wear radio or music headphones while operating machine.

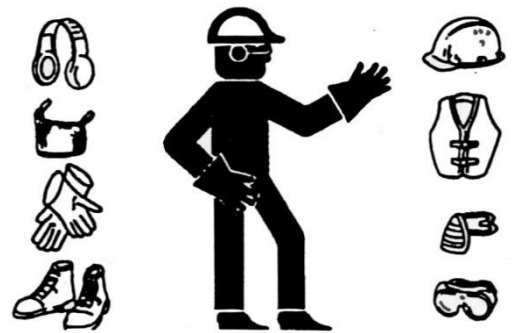

PROTECT AGAINST NOISE

Prolonged exposure to loud noise can cause impairment or loss of hearing.

Wear a suitable hearing protective device such as earmuffs or earplugs to protect against objectionable or uncomfortable loud noises.



HANDLE CHEMICAL PRODUCTS SAFELY

Direct exposure to hazardous chemicals can cause serious injury. Potentially hazardous chemicals used with this equipment include such items as lubricants, coolants, paints, and adhesives.

A Material Safety Data Sheet (MSDS) provides specific details on chemical products: physical and health hazards, safety procedures, and emergency response techniques.



Check the MSDS before you start any job using a hazardous chemical. That way you will know exactly what the risks are and how to do the job safely. Then follow procedures and recommended equipment. (See your dealer for MSDS on chemical products used with this equipment.)

DISPOSE OF WASTE PROPERLY

Improperly disposing of waste can threaten the environment and ecology. Potentially harmful waste used with this equipment include such items as oil, fuel, coolant, brake fluid, filters, and batteries.

Use leak proof containers when draining fluids. Do not use food or beverage containers that may mislead someone into drinking from them.

Do not pour waste onto the ground, down a drain, or into any water source.

Air conditioning refrigerants escaping into the air can damage the Earth's atmosphere. Government regulations may require a certified air conditioning service center to recover and recycle used air conditioning refrigerants.

Inquire on the proper way to recycle or dispose of Waste from your local environmental or recycling center, or from your dealer.

PRACTICE SAFE MAINTENANCE

Understand service procedure before doing work. Keep area clean and dry.

Never lubricate, service, or adjust machine while it is moving. Keep hands, feet, and clothing from power-driven parts. Disengage all power and operate controls to relieve pressure. Lower equipment to the ground. Stop the engine. Remove the key. Allow machine to cool.

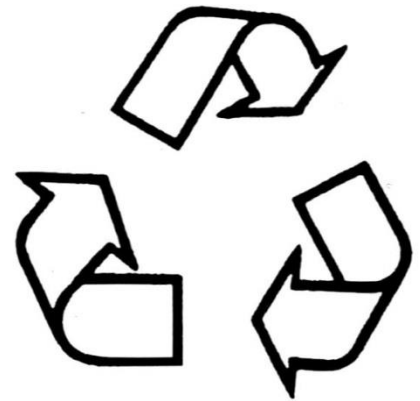

Securely support any machine elements that must be raised for service work.

Keep all parts in good condition and properly installed.

Fix damage immediately. Replace worn or broken parts. Remove any buildup of grease, oil, or debris.

Disconnect battery ground cable (-) before making adjustments on electrical systems or welding on machine.

WORK IN VENTILATED AREA

Engine exhaust fumes can cause sickness or death. If it is necessary to run an engine in an enclosed area, remove the exhaust fumes from the area with an exhaust pipe extension.

If you do not have an exhaust pipe extension, open the doors and get outside air into the area.

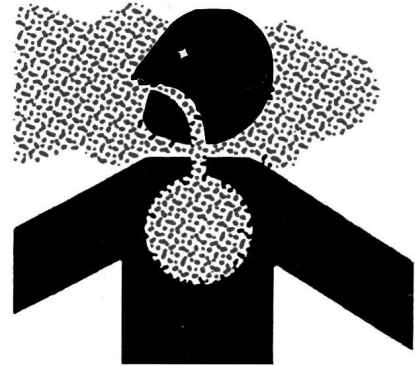

AVOID HIGH-PRESSURE FLUIDS

Escaping fluid under pressure can penetrate the skin causing serious injury.

Avoid the hazard by relieving pressure before disconnecting hydraulic or other lines. Tighten all connections before applying pressure.

Search for leaks with a piece of cardboard. Protect hands and body from high pressure fluids.

If an accident occurs, see a doctor immediately. Any fluid injected into the skin must be surgically removed within a few hours or gangrene may result. Doctors unfamiliar with this type of injury should reference a knowledgeable medical source.



**AVOID HEATING NEAR PRESSURIZED
FLUID LINES**

Flammable spray can be generated by heating near pressurized fluid lines, resulting in severe burns to yourself and bystanders. Do not heat by welding, soldering, or using a torch near pressurized fluid lines or other flammable materials. Pressurized lines can be accidentally cut when heat goes beyond the immediate flame area.



**REMOVE PAINT BEFORE WELDING OR
HEATING**

Avoid potentially toxic fumes and dust.

Hazardous fumes can be generated when paint is heated by welding, soldering, or using a torch.

Do all work outside or in a well ventilated area.
Dispose of paint and solvent properly.

Remove paint before welding or heating:

If you sand or grind paint, avoid breathing the dust.
Wear an approved respirator.

If you use solvent or paint stripper, remove stripper with soap and water before welding. Remove solvent or paint stripper containers and other flammable material from area. Allow fumes to disperse at least 15 minutes before welding or heating.



SERVICE COOLING SYSTEM SAFELY

Explosive release of fluids from pressurized cooling system can cause serious burns.

Shut off engine. Only remove filler cap when cool enough to touch with bare hands. Slowly loosen cap to first stop to relieve pressure before removing completely.



AVOID HARMFUL ASBESTOS DUST

Avoid breathing dust that may be generated when handling components containing asbestos fibers. Inhaled asbestos fibers may cause cancer.

Components in products that may contain asbestos fibers are brake pads, brake band and lining assemblies, clutch plates, and some gaskets. The asbestos used in these components is usually found in a resin or sealed in some way. Normal handling is not hazardous as long as airborne dust containing asbestos is not generated.

Avoid creating dust. Never use compressed air for cleaning. Avoid brushing or grinding materials containing asbestos. When servicing, wear an approved respirator. A special vacuum cleaner is recommended to clean asbestos. If not available, apply a mist of oil or water on the material containing asbestos. Keep bystanders away from the area.

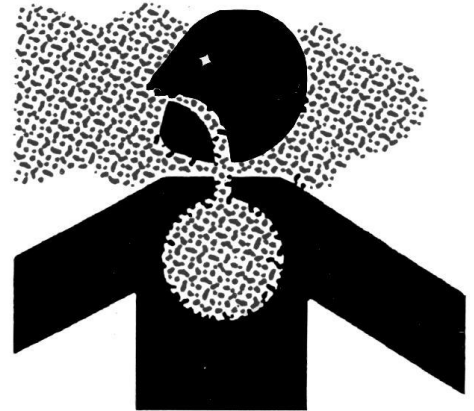

STAY CLEAR OF ROTATING EQUIPMENT

Entanglement in rotating equipment can cause serious injury or death. Keep shields in place at all times.

Wear close fitting clothing. Stop the engine before making adjustments or performing any type service on the equipment.



DIESEL FUEL STORAGE

Proper fuel storage is critically important. Use clean storage and transfer tanks. Periodically drain water and sediment from bottom of tank. Store fuel in a convenient place away from buildings.

IMPORTANT: DO NOT store diesel fuel in galvanized containers. Diesel fuel stored in galvanized containers reacts with zinc coating on container to form zinc flakes. If fuel contains water, a zinc gel will also form. The gel and flakes will quickly plug fuel filters, damage injection nozzles and injection pump.

DO NOT use brass-coated containers for fuel storage. Brass is an alloy of copper and zinc.

FILLING FUEL TANK



CAUTION: Handle fuel carefully. Do not fill the fuel tank when engine is running. DO NOT smoke while filling fuel tank or servicing fuel system.

IMPORTANT: The fuel tank is vented through the filler cap. If a new filler cap is required, always replace it with an original vented cap.

Fill fuel tank at the end of each day's operation to prevent condensation in tank as moist air cools and freezes during cold weather.

Store diesel fuel in plastic, aluminum, or steel containers specifically coated for diesel fuel storage.

Avoid storing fuel over long periods of time. If fuel is stored for more than a month prior to use, or there is a slow turnover in fuel tank or supply tank, add a fuel conditioner to stabilize the fuel and prevent water condensation. Fuel conditioner also reduces fuel gelling and controls wax separation during cold weather.

Consult your engine distributor or servicing dealer for recommendations and local availability. Always follow manufacturer's directions on label.



Read and understand these safety sections before operating or servicing the sweeper. Learn how to stop the sweeper's engines suddenly in an emergency. Only persons who have read the manuals and have been properly trained should operate the sweeper.

- Do not operate the sweeping unit without having the sweeping hood hoses in place.
- Remove the truck's ignition keys whenever working under the truck or sweeper.
- Open (turn off) the optional battery disconnect switch (located beside the battery tray) when working on or near the auxiliary engine or its drive belts. This is to prevent an accidental starting or cranking of the auxiliary engine.
- Do not dump the hopper unless it is on level ground. When you dump, the truck must be in "PARK" and the emergency brake must be engaged. Do not try to dump the hopper over a dock or open pit.
- Whenever working under a raised hopper, make sure the safety chocks (provided with the unit) are in place at the dump cylinders.
- Whenever the hopper is lowered, beware of the area between the hopper and the frame. This is where a crushing injury may occur when either the hopper or the frame moves.
- Do not remove any of the belt guards, or work near drive belts while wearing any jewelry or loose clothing.
- To keep the engines in good condition, always use the proper tools for the job you are performing.
- Additional important safety guidelines are located in the Owner's Manuals for the chassis and sweeper engine.

Safety is of the utmost importance. Most accidents can be avoided by being aware of the conditions, the area and the equipment being operated. Always observe reasonable precautions and be a safe and careful operator.

A. Safety Alert Symbols

The Safety Alert Symbol, accompanied by a word, appears on the decals attached to your sweeper.

When you see one of these symbols It means that your safety is Involved! Be alert and use Caution! Read, understand and follow all safety messages. You should always practice usual and customary safe working precautions in order to avoid serious injury or death. Also, use good common sense to avoid accidents and hazards.

The following one-word cautions used with the symbols are:



CAUTION! This is the lowest level of a safety message.
It warns of possible injury and the signs are black and yellow.



WARNING! These signs will warn you of a serious injury or possible death.
These signs are black and orange.

Always maintain the safety decals in good, readable condition. If the decals are unreadable, damaged or missing, install replacement decals immediately. Contact Stewart-Amos Sweeper Co. for replacement of any decals needed.

All protective safety devices, guards and safety shields should be used and kept in good working condition. They should be inspected daily for any missing, worn or broken components. If any damage arises they must be replaced so they are in good working condition before the sweeper is operated. This must always be done to prevent the possibility of serious injury or death from thrown objects or entanglement. Never remove, modify or cut any of the sweeper's protective shields and guards!

The sweeper must be equipped with a fire extinguisher, rated for all fires, located in an accessible and visible area. Never obstruct access to the fire extinguisher. It should be inspected routinely by a certified inspector for operational use, and replaced as needed.

B. Chassis Driver Safety Instructions

1. The sweeper operator must possess a valid motor vehicle license and meet any other requirements of the state in which the sweeper is operated. Contact your local State Department of Public Safety for any special licensing requirements needed to operate the sweeper in your area.

2. The operator of the sweeper must be trained and knowledgeable in the use and safety of this sweeper. This includes reading and completely understanding the Owner/Operator Manuals for the sweeper, the truck and the auxiliary engine. If the operator has any questions or does not fully understand information in any of the Manuals, contact the manufacturer of the equipment discussed in that Manual for a detailed explanation. Never allow an untrained or unqualified driver to operate the sweeper.
3. New operators should be trained in an open area, one that is clear of obstructions, prior to operating on public roadways.
4. Never use drugs or alcohol immediately before or while driving/operating the sweeper. Drugs and alcohol will affect the operator's alertness and coordination, which can affect their ability to operate the sweeper safely. Any operator using prescription or over-the-counter medication must consult a medical professional to determine any side effects of the medication that might reduce their ability to operate the sweeper safely. Never knowingly allow anyone to operate the sweeper when their alertness or coordination is impaired, as doing so could cause serious injury or death to the operator or others.
5. **Prolonged exposure to loud noise may cause permanent hearing loss!** Sweeper operation can be noisy enough to cause permanent hearing loss. We strongly recommend that operators always wear hearing protection when the noise in the cab exceeds 80 dB. Noise over 85 dB, when sustained over an extended amount of time, has been shown to cause hearing loss. Noise exceeding 90 dB over an extended amount of time will cause permanent or total hearing loss. Please note that hearing loss from loud noises from sweepers, radios, mowers, chain saws and other such sources close to the ear is cumulative over a lifetime with no hope of natural recovery.

C. Operator Safety Instructions

THE SAFETY INSTRUCTIONS LISTED BELOW ARE INCLUDED IN ORDER TO PREVENT ACCIDENTS, SERIOUS INJURY, DISMEMBERMENT OR DEATH TO THE OPERATOR AND/OR ANY BYSTANDERS OR ANIMALS. READ AND UNDERSTAND THESE INSTRUCTIONS FULLY BEFORE OPERATING THE SWEEPER OR THE TRUCK.

1. NEVER attempt to get onto or off of the sweeper or truck while the machine is moving.
2. Start the truck engine and auxiliary engine only when the operator is seated in the truck's operator seat with the seat belt fastened. Read the truck and Auxiliary engine Owner/Operator's Manuals for proper starting instructions and operation.
3. Operate the sweeper controls only when you are properly seated with the seat belt fastened.

4. **Drive or transport the sweeper only at safe speeds.** Familiarize yourself with the driving characteristics of the truck and how it handles before operating or transporting on streets and highways. Serious accidents and injuries can result from driving this sweeper at unsafe speeds. Make sure the truck's steering, brakes and wheels are in good condition and that all components work properly. Before driving the sweeper, determine the safe speeds for the machine and operating conditions. Abide by the following rules:

- Test the sweeper at a slow speed and increase the speed slowly. Apply the brakes smoothly to determine the stopping characteristics of the sweeper. Remember, as you increase the speed of the truck the stopping distance also increases. When driving on wet or rain-slicked roads and down hills, the braking distance also increases. Use extreme care in these situations and reduce your speed. Never operate the sweeper with weak or faulty brakes.
- Obey all traffic laws and regulations. Never exceed the posted speed limit.
- Please be aware that the sweeper has a high center of gravity. This factor may be further increased when the hopper and/or the water tank are full. Make sure extreme caution is used when driving at highway speeds. Slow down for sharp corners to avoid tipping or turning the sweeper over.
- Only drive the sweeper at speeds determined to be safe and that allow for proper control of the machine while driving and during an emergency.

5. Before starting into the sweeping operation, make sure that all warning signal lights are connected, visible and working. The sweeper's headlights, brake lights, backup lights and turn signals should be routinely inspected for correct functioning. Immediately repair any non-functioning light(s).

6. **Use EXTREME CAUTION when operating the sweeper in traffic.** The sweeper is equipped with warning signals and flashing lights. Use these to alert motorists and pedestrians of the sweeper's presence and relatively slow speed.

7. **Do not exceed** the rated operating speed for the truck and auxiliary engines. Sweep at a speed that allows safe operation and control of the sweeper. This will depend on the street condition and the type and amount of debris being collected. The normal speed range is between one and three miles per hour (mph). Slow down for parked cars, curbs, corners, protruding signs and any other obstacles. Use slow travel speeds when you are operating on or near drop-offs, ditches, steep slopes, power lines, and any overhead obstructions, or when avoiding debris and foreign objects. Excessive operating speeds can cause engine and sweeper components to fail.

8. **NEVER** reach outside of the truck cab window/door to pick up a foreign item or to clear obstacles such as a road sign or tree limb that is obstructing passage. Instead, stop the sweeper, shut down all sweeping components and wait for all the parts to come to a complete stop. Only then should the operator exit the cab to handle the obstacles.

9. **DO NOT** raise the sweeper's broom components when bystanders are within 25 feet of the sweeper. Make sure that the curb brooms have come to a complete stop before raising them from the street surface. Raising the sweeping components exposes the rotating brooms, which creates a potentially serious hazard due to thrown objects or from direct broom contact
10. **DO NOT** operate the sweeper if the fan's exhaust (blast) hose is removed, damaged or improperly installed on the outlet tube or sweeper hood. The fan can throw objects, resulting in serious injury to the operator or bystanders.
11. Any objects that could become entangled in a sweeping component, as well as any that could plug the suction tubes, **MUST** be removed from the pavement or surrounding area prior to sweeping. Objects such as chains, rope, cable and wire could become entangled in the rotating parts of the sweeping component and cause mechanical damage as well as serious injury.
12. **KEEP AWAY FROM ROTATING CURB BROOMS** to prevent entanglement and possible serious injury or death. Be aware that rotating brooms can pull bystanders into the sweeper.
13. **KEEP AWAY FROM SUCTION** Components such as the suction head and suction hoses. Air enters the fan housing with a great amount of force. Also use extra caution when the power is running and the hopper is raised. **DO NOT** wear loose clothing or position yourself or others near the fan- housing inlet. This is necessary in order to prevent being drawn into the sweeper, which can cause serious injury or death. Keep any items that might be drawn into the sweeper hood (such as tools and replacement parts) clear of the sweeper before starting operation.
14. **NEVER ALLOW CHILDREN TO PLAY ON OR UNDER THE SWEEPER OR TO OPERATE THE SWEEPER'S CONTROLS.** Children can slip and/or fall off the sweeper or cause the sweeper components to shift, which can result in serious injury (crushing themselves or others) or death.
15. **AVOID** body contact with debris collected in the hopper. Always use protective clothing, including gloves and eye protection, when servicing or working in or around the hopper. Debris in the hopper can cut or puncture, so leather gloves are recommended when operator or others need to handle hopper debris.
16. **NEVER SWEEP** Into hot **OR BURNING DEBRIS**. A burning object, even something as small as a lit cigarette, could ignite the collected waste inside the hopper. This could possibly destroy the sweeper and inflict serious injury or death to the operator of the sweeper and/or bystanders.

17. DO NOT ALLOW THE SWEEPER TO COME IN CONTACT WITH POTENTIALLY DANGEROUS AND/OR HAZARDOUS MATERIAL. Hazards may include, but are not limited to, the following:

- Cutting Hazards – Broken Glass, Lumber with Protruding Nails
- Corrosive Materials – Batteries, Acids and Bases
- Fire Hazards – Fuel Spills, Burning Materials
- Chemical Hazards – Chemical Spills, Discarded Chemical Containers
- Biological Hazards – Decaying Carcasses, Biomedical Waste
- Carcinogenic Materials – Asbestos
- Radioactive Hazards – Radioactive Waste, Radioactive Material



CAUTION

These types of material usually require special handling to ensure safe collection and proper disposal. These items should not be collected by the sweeper, nor can they be disposed of in a general landfill site like most sweeper- collected waste. Contact the appropriate authority for the collection and disposal requirements of any such material.



WARNING

18. ALWAYS wear OSHA-approved and required personal protective equipment when coming in contact with, and/or removing, potentially dangerous and hazardous material that has been collected by the sweeper or that is obstructing the sweeper components. Use extra caution with dangerous and hazardous material such as decaying carcasses, sharp objects, chemicals, etc.

19. The sweeper operator should use EXTREME CAUTION when operating within 25 feet of a bystander. Stop sweeping if anyone comes within 25 feet of the sweeper! Also use caution when sweeping dense objects such as gravel or broken glass. Objects may become dislodged and then propelled a distance of up to 25 feet.

20. **EXTREME CAUTION** should be used when backing up the sweeper. Make sure no bystanders, animals, signs, vehicles or buildings are in the sweeper's path. Ensure that the sweeper is not being backed into the path of vehicle or pedestrian traffic.

21. **ALWAYS CHECK** to make sure no bystanders or animals are within 25 feet of the sweeper when cleaning the hopper or dumping its contents. The hopper contents may exceed several thousand pounds and could fall on or crush a bystander or animal.

D. Maintenance Safety Instructions

The safety instructions listed below are designed to prevent accidents, serious injury, dismemberment or death to the operator and/or any bystanders or animals. Read and understand these instructions fully before performing any maintenance on the sweeper or the truck.

1. Periodically inspect all of the moving parts for wear, and replace them as needed with authorized service parts. You will need to look for leaky or loose fasteners and fittings and worn or broken parts. Check to make sure all cotter pins and washers are in place. Maintain your sweeper in good working order to prevent serious injury.
2. Perform a walk-around inspection on the entire sweeper prior to each use. Accidents may occur, or damage could result to the sweeper, if it is not properly maintained and in good working order. Check the following:
 - Make sure that all safety shields and guards are in place and in good working condition.
 - Check the tires for tread wear and make sure the tire pressure is at the rated PSI.
 - Make sure all the fluid levels are full. Replenish if necessary.
 - Make sure the fuel, oil and coolant caps are on and tightened.
 - Check for any loose bolts, worn or broken parts, leaky or loose fittings, or pinched hydraulic hoses.
 - Make sure any replacements are the correct size and properly installed.
3. **DO NOT** approach or inspect the sweeper fans while they are rotating. Shut down the sweeper and wait for all rotating motion to stop completely before inspecting or performing maintenance.
4. **USE EXTREME CAUTION** when climbing onto the sweeper to perform repairs, maintenance or routine cleaning. Use all appropriate stands and ladders to access the areas that cannot be reached from the ground level.



5. Before performing any maintenance on the sweeper, stop both the truck and auxiliary engines. Place the transmission in park and set the parking brake. After the engines have been turned off, remove the keys to prevent inadvertent or accidental starting.
6. **NEVER** operate the truck or auxiliary engine in a closed building or without adequate ventilation. The exhaust fumes can be hazardous and deadly to your health.
7. **NEVER** attempt to clean, adjust, repair, lubricate, remove obstructions or perform any type of service to the sweeper or its components while the sweeper is in motion and/or the truck and auxiliary engine is running. Completely shut down the sweeping components, the truck engine and the auxiliary engine and wait for all motion to come to a complete stop before servicing the sweeper.
8. **NEVER** remove the sweeper's exhaust hose (going to the sweeping hood) in order to perform repairs or maintenance while the sweeper is operating. Objects could be propelled from an open hose at a very high velocity, causing serious injury or death. Always turn off the sweeping components, the truck and auxiliary engines, and then wait for all motion to come to a complete stop before servicing any sweeper component.
9. **NEVER** crawl under the hopper bin while the hopper is in the raised position until the hopper has been secured with the safety prop in position. An accidental operation of a lifting lever or a hydraulic failure may cause a sudden drop of the unit.
10. **NEVER** come into contact with the hot surfaces on the bottom of the drag shoes. Use gloves and eye protection when inspecting or servicing hot components.
11. **ALWAYS** remove the negative battery cable from the battery, or turn off the battery disconnect switch, prior to performing maintenance on the electrical system. This must be done in order to prevent accidental circuit shorting and sparks, which can result in wiring damage, fire and/or personal injury.
12. Battery post terminals and related parts contain lead and lead compounds. These chemicals are known to the state of California to cause birth defects or other reproductive harm. **ALWAYS WEAR GLOVES DURING, OR WASH YOUR HANDS AFTER, HANDLING THEM.**
13. **NEVER** operate the sweeper with leaking hydraulic oil or fuel as this could present a hazard. **DO NOT CHECK FOR LEAKS WITH YOUR HANDS!** Use a heavy piece of paper or cardboard, or some other suitable object. High- pressure streams of oil coming from leaks or breaks in the line could penetrate the skin. If this happens, have the injury treated immediately by a physician who has knowledge and skill in this situation.
14. **NEVER** attempt to tighten a connection or repair a pump or hose while the system is pressurized. Always shut down the truck and auxiliary engines first, in order to relieve the hydraulic oil pressure, before performing any repairs to the hydraulic system.

15. **USE EXTREME CAUTION** when refueling the sweeper. Fuel is highly flammable and explosive, and can be dangerous if not handled safely. Follow the precautions listed below to reduce the danger involved in refueling:

- Turn off the truck and auxiliary engines before refueling.
- **DO NOT** refuel while smoking or near an open flame.
- **DO NOT** store the sweeper, with fuel in the tank, in a building where fumes can reach an ignition source.
- When filling the tank use a plastic funnel — without a metal screen or filter — in order to avoid fire or an explosion caused by static electric discharge.
- **DO NOT** spill fuel, as it can damage plastic and painted surfaces. Clean up any spilled fuel immediately.

DO NOT MODIFY OR ALTER THIS SWEEPER. Do not allow anyone to modify or alter this sweeper, its components, or any of its sweeper functions.



I. Warranty Information

WARRANTY CERTIFICATE

Stewart-Amos Sweeper Co. warrants each new machine manufactured to be free from defects in material and workmanship under normal use and service. The obligation under this warranty is limited to replacing F.O.B. its factory, Harrisburg, PA:

Any **PART** and labor within **ONE YEAR** (twelve months) or **ONE THOUSAND** (1000) HOURS, whichever occurs first, after making delivery of such machine to the original purchaser. This warranty is expressly in lieu of all other warranties expressed or implied and of all other obligations or liabilities on its part, and it neither assumes nor authorized any other person to assume for it any liability in connection with the sale, servicing or repair of any machine manufactured by it.

Stewart-Amos Sweeper Co. reserves the right to have any part being claimed for warranty returned, at customer expense, for inspection and determination that the part was factory defective.

Stewart-Amos Sweeper Co. reserves the right to make changes in design or to make additions to or improvements on its products previously manufactured.

Stewart-Amos Sweeper Co. – WARRANTY POLICY

Stewart-Amos Sweeper Co. provides warranty to the original purchaser of a new product, that the same is free from defects in materials and workmanship that may cause performance failures, subject to the conditions stated herein.

The warranty is limited to a period of one (1) year from the date of the original purchase or 1000 hours, whichever occurs first, included are parts and labor costs associated with the warranty.

GENERAL CONDITIONS

Stewart-Amos Sweeper Co. will honor warranty claims provided:

The unit is properly registered. Registration form is located at the front of the operator's manual.

Registration form must be received by Stewart-Amos Sweeper Co. within 45 days of the sale. Failure to receive said warranty registration form within the prescribed time will cancel warranty coverage for the product.

The failure occurs within the warranty period and is covered under the terms of our written warranty. The repairs are made and an authorized Stewart-Amos Sweeper Co. dealer has submitted a warranty claim within 30 days of completion of repair.

The unit has not been altered in any way without prior written approval by Stewart-Amos Sweeper Co. All warranty repairs reimbursable must be performed by an authorized dealer using Stewart-Amos Sweeper Co. approved replacement parts. Failure to repair properly voids future warranty.

ITEMS NOT COVERED BY WARRANTY

Set-up and pre-delivery services, service calls, diagnostics, or after sales adjustments due to normal operations, including travel time/mileage.

Sweepers sold for use outside of North America.

Repairs, modifications or alterations to the machine without the express written consent of Stewart-Amos Sweeper Co.

Including but not limited to normal wear parts such as brooms, drag shoes, rubber deflectors, filters, oil, fuel, chains, belts, brakes or other wear parts.

Items that, in the opinion of Stewart-Amos Sweeper Co. have been subject to misuse, abuse, negligence, accident or improper maintenance.

Failures resulting from the machine being operated in a manner or for a purpose not recommended by Stewart-Amos Sweeper Co.

Rentals, consequential or collateral damage, down time costs, or lost revenue incurred due to a failure during the warranty period.

Consumables or shop supply materials such as paint, anti-freeze, oil, fuel, bolts.

ITEMS COVERED BY SEPARATE WARRANTIES

Parts and components such as the chassis, auxiliary engine, pump, motors, and other similar major components which are under separate warranties from their respective manufacturers. Service for these components can be obtained from their service facilities in the United States. In some circumstances, extended warranties are available at an extra cost. Please contact your Stewart-Amos Sweeper Co. dealer for information on these extended warranties.

THERE IS NO OTHER EXPRESS WARRANTY. ALL IMPLIED WARRANTIES OF MERCHANT LIABILITY AND FITNESS FOR USE ARE LIMITED TO THE DURATION OF THE EXPRESSED WARRANTY.

IT IS EXPRESSLY UNDERSTOOD THAT STEWART-AMOS SWEEPER CO. WILL NOT BE LIABLE FOR ANY OTHER INJURY, LOSS, DAMAGE OR EXPENSE, WHETHER DIRECT OR CONSEQUENTIAL, INCLUDING BUT NOT LIMITED TO LOSS OF USE, INCOME, PROFIT OR PRODUCTION, OR INCREASED COST OF OPERATION, OR SPOILAGE OF OR DAMAGE TO MATERIAL, ARISING IN CONNECTION WITH THE SALE, INSTALLATION, USE OF, INABILITY TO USE, OR THE REPAIRS OR REPLACEMENT OF STEWART-AMOS SWEEPER CO.'S PRODUCTS.

STEWART-AMOS SWEEPER CO. RESERVES THE RIGHT TO MAKE CHANGES IN DESIGN OR TO MAKE ADDITIONS OR IMPROVEMENTS ON ITS PRODUCTS WITHOUT IMPOSING ANY OBLIGATION UPON ITSELF TO INSTALL THEM ON ITS PRODUCTS PREVIOUSLY MANUFACTURED.



II. Customer Assistance

Stewart-Amos is committed to 100% customer satisfaction. Our employees are trained to provide fast and dependable service to our valued customers, who we consider our friends and family. Our headquarters are located in Harrisburg, Pennsylvania, where we have a state-of-the-art manufacturing and production facility. This facility includes a department that is designed for complete servicing and refurbishing of sweepers.

Our contact information is:

Stewart-Amos sweeper Company

2700 Paxton Street

Harrisburg, PA 17111

Direct: (717) 564-5600

Toll Free: 1-800-482-2302

Fax: 717-901-2326

Email: parts@stewart-amos.com

To assure prompt delivery and processing of your order, you will need to have the following information available before contacting us:

1. Locate the "sweeper and Customer Information" sheet at the front of this Manual. You will need to have the type and serial numbers for the power module engine, the chassis, and the sweeping unit.
2. The part number(s), description(s) and the quantity needed. We will also need to know if the part is for the right or left, front or back, and any other relevant information.
3. Shipping information. Orders are shipped by UPS unless otherwise specified. If your part(s) exceed the weight restrictions for UPS delivery, then a freight trucking company will be used for shipment. We will need to know how you want your order shipped; next day air, second day air, trucking company, cheapest possible, etc.

Our parts representatives make every effort to ship all in-stock parts the same business day if the order is placed before 12:00 noon, Eastern Time. For any order received after noon we will still make every effort to ship the same day. However, if this is not possible the order will be shipped the following business day.

Payment procedures: Stewart-Amos Sweeper Co. accepts MasterCard and Visa. If you are not using a credit card for payment, the order will be shipped C.O.D. unless prior arrangements have been made through our accounting department.

III. General Sweeper System Description

As an owner or operator of a Stewart-Amos Galaxy series sweeper, you will need a basic understanding of the sweeping system. This section is designed to help you understand the system without being too technical.

The Galaxy R-Series uses a “closed loop” and/or regenerative airflow system, which is contained inside a sweeping hood (also sometimes termed a ‘sweeping or pickup head’), in order to vacuum up debris. To increase the sweeper’s vacuum power, a portion of the system’s air may be vented out of the system as exhaust air. The remaining air is recirculated in the system, which produces a blasting force of air under the sweeping hood.

To maintain the high velocity of air contained within the sweeping hood, metal drag shoes on the sides, as well as flexible rubber flaps called “curtains,” are bolted on the front and back of the sweeping hood.

Power for the sweeper unit comes from the auxiliary engine, which is mounted on the sweeper frame behind the truck cab. The truck’s main fuel tank also supplies fuel to the auxiliary engine. Power to the sweeper is provided by the auxiliary engine, which propels a fan by way of a drive-belt that is connected to a bearing-mounted drive shaft.

The balanced and abrasion-resistant fan draws air from inside the hopper and forces it out of the opening in the fan housing. A replaceable rubber liner is installed in the fan housing to prevent excessive wear.

The Sweeping Process:

1. The vacuum created by the fan, which is located outside the hopper, forces air drawn from the hopper down the pressure hose and into the upper/rear pressure chamber of the sweeping head. This air is then funneled across the front of the chamber, and out a slot called the ‘blast orifice.’ As the air is pushed through the blast orifice, it is transformed into a high velocity airstream that is channeled forward and downward onto the sweeping surface in the sweeping head’s lower/front chamber
2. The effect of this air blast is to both loosen the debris and lift it up off the pavement surface.
3. The debris is then transported across to the outflow (suction inlet) side of the sweeping hood. Flexible rubber flaps, called ‘curtains,’ are bolted to the front and back of the sweeping hood. These curtains, along with the metal drag shoes on each end, contain the high air velocity within the sweeping hood.
4. The vacuum created by the fan, pulls the debris up through the suction hose and into the hopper.

5. When the debris enters the hopper, a number of strategically placed water nozzles are used to decrease the amount of airborne dust. Once the debris and dust comes into contact with the water it becomes heavier and loses its speed, which causes the heavier objects to fall to the bottom of the hopper.
6. The air is then drawn through a screen in the top of the hopper where any remaining lighter objects are removed.
7. Any remaining fine particles of dust in the air stream are pulled through the screen and into the dust separator, which is located in the front of the hopper.
8. As a fan pulls the air from the dust separator, it creates a centrifugal force that throws the remaining fine dust against the walls of the separator.
9. The fan then draws the cleaned air from the dust separator back into the fan housing and the entire process begins again.

A. Auxiliary Engine Shroud

The auxiliary engine shroud contains two upward opening doors, one for each side of the power module. The shroud's upper door has struts to support the door when it is open.

The lower doors open downward and allow access to the hydraulic system components on the left side of the power module. All doors open independently of each other.



B. Curb broom



The sweeper's rotating hydraulic curb or gutter broom has been designed to loosen the debris from the ground and then direct it across, and in front of the sweeping hood so it can be picked up.

The gutter broom(s) is mounted under the chassis, in front of the sweeping hood. Gutter brooms may be mounted on the left and/or right side of the sweeper. The broom is suspended from the frame on a hydraulically controlled arm that is operated using the switch(es) on the control panel inside the truck cab.

The hydraulic motor, which turns the broom's bristles is mounted inside the disc that spins on the end of the arm. When the broom is not in use, it is hydraulically held and locked into the travel position up and off the pavement and under the truck. This travel position allows for minimum truck width and maximum ground clearance for travel at road speed.

C. Hopper

The hopper is designed to hold the debris that has been collected by the sweeping hood. It is



constructed of industrial-grade stainless steel.

The hopper is mounted to a heavy-duty frame that has been fastened to the truck's chassis, providing a stable base on which to mount the hydraulic cylinders. These cylinders are used to raise the hopper into a dump position.

An inspection door on each side of the hopper provides easy access for hopper clean-out after dumping. You will also find them useful for placing any objects that are too large to fit under the sweeping hood to be placed into the hopper.

A full-width door has been installed on top of the hopper to provide easy access for cleaning the hopper's separator screens. There are four screen panels per unit.

There is a separate switch inside the cab that opens (and re-latches) both the dump door and the screen door.

D. Hydraulic System

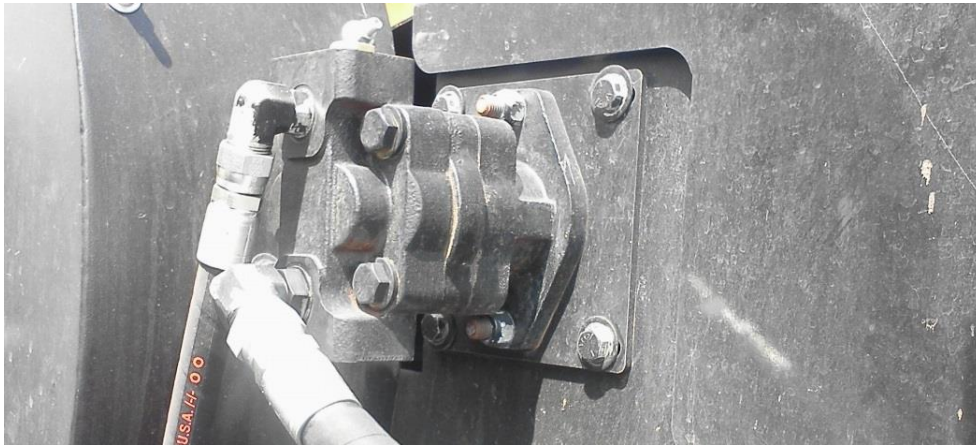

Hydraulic fluid is pulled from the reservoir into the mechanically driven hydraulic pump that is mounted directly to the end of the crank shaft of the engine. The pump passes the pressurized hydraulic fluid into the manifold, which is mounted on the left side of the power module. Valves attached to the side of the manifold are operated electrically from the sweeper's in-cab control panel. These valves are used to channel fluid flow to the curb brooms for broom operation, as well as to raise and lower the hood and hopper, and to power any other hydraulic functions.





OPTIONAL: A 12-volt auxiliary hydraulic pump, which is powered by the truck's 12-volt battery, enables the operator to control any hydraulic functions without running the sweeper's auxiliary engine.

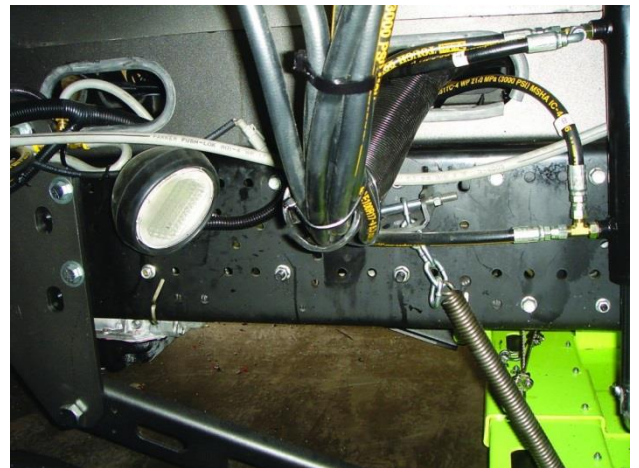

E. Lights, Flashers, Alarm

The sweeper is equipped with a number of electric LED lights and flashers. Lights are standard for the broom(s). These enable the driver/operator to see well when operating at night.



OPTIONAL: Lights illuminating the sweeping hood are also controlled by switches on the control panel.

OPTIONAL: A flashing bar light, strobe, or beacon light may be positioned on the top of the truck cab. These lights are used to alert pedestrians and motorists of the presence of the relatively slow moving sweeper machine. All lights are controlled via switches mounted on the control panel inside the truck cab.

F. Spray Bar

An optional spray bar is available. It is mounted to the front of the sweeper and provides additional dust suppression whenever the sweeper is being operated in extremely dusty conditions.

An electric water pump, which is powered by the truck's 12-volt system, supplies water to several nozzles. These nozzles are positioned along a pipe that is attached beneath the truck's front bumper.



G. Sweeping Hood

The central sweeping component of this air sweeper is the sweeping hood. The sweeping hood is mounted to the underside of the frame on both sides by a set of drag arms, tension springs and hydraulic lift cylinders.



A switch on the control panel operates the lift cylinders. The lift cylinders, along with the tension springs, control the vertical movement of the head.

The sweeping hood is connected to the fan housing and the hopper inlet tube by two large hoses. One hose is on the pressure (outflow) side while the other hose is on the vacuum (suction) side.

The pressure side hose is connected from the fan housing to the pressure inlet tube on the hood. The bottom of the vacuum hose is connected to the suction inlet tube on the hood, and the other end connects to the transition ring that seals against the hopper inlet tube when the hopper is in the lowered position. Both of these hoses are held in place by two metal band clamps, one at the top and the other at the bottom.

H. Water System

It is necessary to control the amount of airborne dust within the sweeper's airflow system in order to avoid unnecessary wear of the fan, fan housing, hopper and sweeping hood.



This is accomplished by introducing a water spray at various locations on both the inside and outside of the sweeper. The dust suppression system should be used whenever the sweeper is operated unless it is during wet weather conditions.

Here's how the dust suppression system works: Water is pumped out from the bottom left side of the sweeper's polyethylene water tank via electric water pumps. This has been installed to force water out of the various spray nozzles that are located inside the hopper, around the sweeping hood and ahead of the gutter broom (and optional right side gutter broom).

Each spray nozzle produces a very fine mist that mixes with the dust and reduces the amount of abrasive airborne particles coming in contact with the sweeper components.

When water enters the sweeping hood it is drawn into the suction hose, where it continues to mix with the airborne dust. Once these water-laden dust particles enter the hopper they settle to the hopper floor.

The water tank fill opening is located on the right side of the power module.

By reducing the amount of abrasive airborne dust, the fan life is extended, as is the time between maintenance replacements of the fan housing liner. Use of the dust suppression system also reduces the amount of dust vented from the fan housing's exhaust.

I. Dual Steering

Dual steering is an option that allows the driver/operator of the sweeper to control the sweeper and chassis from the left or right hand side of the truck.

Major components relative to vehicle operation, (such as the steering wheel self-cancelling turn signals, the brake and accelerator pedal) are duplicated on both sides. Operating the sweeper from the right hand side gives the driver/operator better control while sweeping areas on the right side of the truck.





J. Hand Hose

The hand hose is a valuable option that's designed to clean areas that are hard to get to, for example shallow catch basins, parking islands and fence edges. The area that is otherwise inaccessible to the sweeping head. It is mounted on the back of the sweeper. The hand hose operates on fan-produced vacuum from within the hopper. It attaches to a spring loaded helper arm and a transition plate. This transition plate is hinged and pivots across a hole in the dump door and is latched into position. To



operate this function a blocking plate must be placed in the suction tube between the hopper and the pickup head. This allows more suction to handle hose instead of drawing air from the pickup head. To install the blocking plate, lift the hopper and place the blocking plate over the suction tube and then put the hopper down again.

IV. SWEEPER STARTUP PROCEDURES AND OPERATION

The following sections briefly cover the operation procedures for the sweeper's main components. It is best to know and understand the sweeper before use. Read this entire section for information to help you get started.

Before attempting to operate this sweeper, it is important to read and understand all the instructions and control functions in this manual.

Also, read the information in the Truck Owner's Manual.

Always check the auxiliary engine's oil and coolant levels prior to the sweeper's first startup of the day. Follow the maintenance procedures outlined in Section VI, PERIODIC MAINTENANCE SCHEDULES, as well as the maintenance procedures required in the auxiliary engine manufacturer's Owner's Manual.

THE FOLLOWING SECTIONS BRIEFLY OUTLINE THE OPERATIONAL PROCEDURES FOR THE R-SERIES SWEEPER'S MAIN COMPONENTS.

BEFORE ACTUALLY OPERATING THE SWEEPER, PLEASE READ THIS ENTIRE SECTION CAREFULLY.

A. Control panel

The control panel is located inside the cab and mounted within easy reach of the driver. The controls are clearly marked and a map light is mounted above the controls to illuminate controls for night operation. As an optional part of the controls there are a series of indicator lights that warn for low hydraulic oil level, low water level and high hydraulic oil temperature.

This system uses an electric throttle that is also mounted on the sweeper control panel.

An hour meter is located at the bottom of the engine tachometer. This records the sweeper engine's run time. This gauge is important and should be checked periodically to detect any maintenance requirements.

On the top left of the control panel is an oil pressure gauge and on the right is the temperature gauge. All Stewart Amos Sweeper Co. sweepers use a shutdown system that will shut down the auxiliary engine in case of loose of oil pressure or over heating situations. This will automatically reset once the key is returned to the off position.



B. Bleeder Valve (Throttle Type Lever)

The throttle type lever located on the right side of the chassis gear selection lever is used for mechanically opening and closing the bleed door on the blower housing. The purpose of this mechanical adjustment is so that the actual position of the door can be monitored for optimizing sweeping efficiency.



C. Auxiliary Engine Control System

Always check the auxiliary engine's oil and coolant levels prior to the sweeper's first startup of the day.

Look at the control panel to make certain that all switches are turned off. Exception: If the optional beacon/strobe light switches are preset to ON, the lights will automatically flash when the chassis engine ignition switch is turned to ON.

All engines are equipped with a glow plug function for cold weather applications by turning the key slowly until the glow plug light on the engine control panel lights. The light will light when turning the key between the run position and the start position. If you hold the glow plugs on, they will activate for 30 seconds and then turn off automatically. This is to prevent the glow plugs from burning out. If more heating is required the glow plugs may be activated for another 30 second period as required.

Start the engine with the throttle in the idle position. The sweeper is equipped with a safety shutdown system that will automatically shut the auxiliary engine off in the event of high coolant temperature or low oil pressure. Let the engine run for several minutes (until it warms up) before operating the sweeper.



D. Sweeping

To begin sweeping, start the auxiliary engine and set the throttle to the desired RPMs. Turn on all warning lights, strobe lights and beacons that will be used while sweeping. Always use the lowest possible throttle position to accomplish a desired sweeping job. Turn 'ON' the switch (es) that correspond to the component(s) of the desired dust suppression.

During operation, the sweeper is typically driven between 1 and 15 mph, depending on maneuverability and the amount of debris to be picked up. Avoid sweeping over wood, large sticks and pieces of cardboard. These will clog the intake tube and may even cause damage to the intake hose.

When using the curb broom watch for large amounts of wire, which may become tangled in the broom. When you see these objects, stop, pick them up by hand and place them in the hopper through the side inspection doors.

DO NOT sweep too closely to a curb line or catch the hood runners in large holes. Catching a runner may twist, warp or otherwise damage the pickup hood, which is an expensive item to replace.

To raise the sweeping hood, press the PICKUP HEAD UP switch. The sweeping hood must be fully raised to provide maximum ground clearance before traveling. Always check to ensure the sweeping hood is completely raised prior to driving on a public roadway. Always turn 'OFF' the sweeper power switch before driving on the roadway, in order to prevent accidental engagement of the hood, brooms or other sweeping components.

A. E. Sweeping Condition Control

The sweeping condition control is the THROTTLE TYPE LEVER positioned between the seats close to the gear shift lever. This controls a damper located inside the fan housing, which can be used to direct all the airflow down the pressure hose and into the sweeping hood. Alternatively, it will divert a portion of the airflow to an exhaust port located directly beneath the hopper.

When sweeping curbs and heavier material, the damper door should be in the 'heavy' (closed 100%) position. This is accomplished by pulling the lever towards the rear of the cab, thus closing the door. This will direct the airflow to the sweeping hood, which produces the maximum blast in the sweeping hood's pressure inlet.

When sweeping light weight material, such as leaves, the damper door should be in the 'light' (open 100%) position. This is accomplished by pushing the lever forward towards the dash of the cab, thus opening the door. This decreases some of the volume of airflow to the pressure inlet, reducing the air pressure applied against the rear of the front curtain. This allows debris to pass beneath the front curtain more easily.

To sweep both light and heavy material in one pass, open and close the air bleeder as you sweep. Through practice, it will not take long to become skilled in using this method to efficiently sweep various types of material.

Air bleeder door shown 100% open

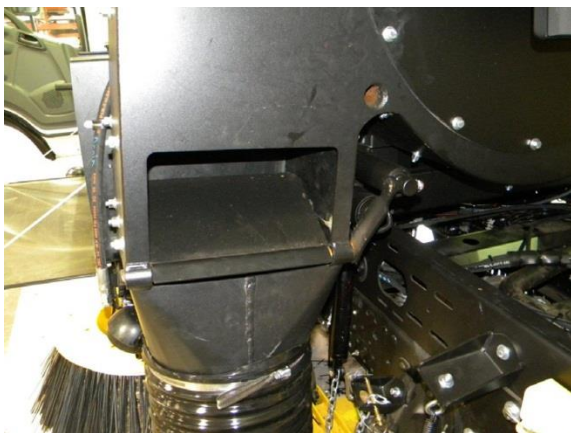

Air bleeder door shown 100% closed

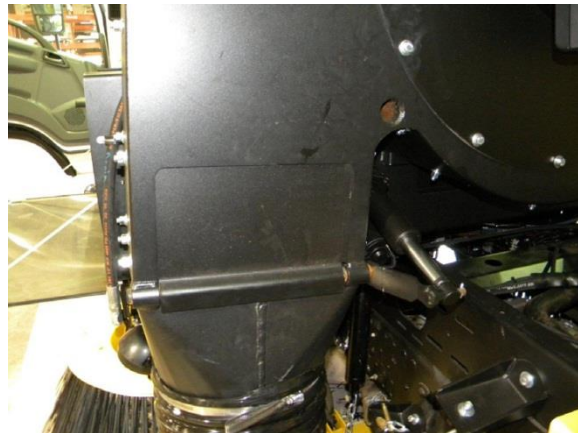

F. Gutter Broom Operation

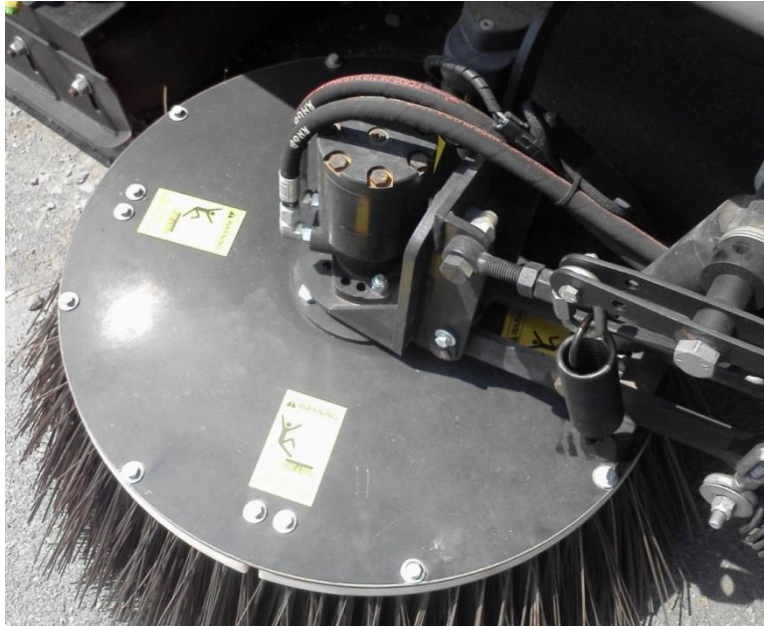

- To make the outside edge of the broom ‘dig’ harder into the curb line, press the broom tilt switch (s) UP.
- To reduce the broom tilt press the broom tilt switch (s) DOWN.

To extend the life of gutter broom’s bristles, we recommend the broom be used only for sweeping curb lines.

When driving to-and-from job sites, or any time the gutter broom is not in use, raise the broom to the stored position. Always keep the broom in this position when you are traveling, in order to provide maximum ground clearance for safe transport. Also, turn ‘OFF’ the power switch on the control panel to avoid accidental engagement of the hood, brooms or other sweeping components while transporting.

G. Dust Suppression System

To use the dust suppression system, first turn on the auxiliary engine system by turning the switch on the control panel to ‘ON.’ Press the switch to ‘ON,’ which controls the water functions as desired. As

conditions change, the water switches may be turned 'ON' and 'OFF.' The amount of time it takes to empty the water reservoir will depend on the number of switches in use and the length of time they are used.

When using a hydrant to fill the water reservoir, always allow the water to run for a short period of time before filling the reservoir. This will allow any sediment that may be trapped in the water line to flush out.

The sweeping hood and hopper spray nozzles should always be 'ON' when sweeping, except during rainy conditions. The switch for the left/right gutter broom(s)/dust suppression, as well as the switch for the sweeping hood, may be turned 'ON' and 'OFF' as needed.

note: using excess water to wet down leaves and other light debris tends to make them stick to the pavement. Sometimes neither the blast force nor the vacuum suction can remove such wet debris.



H. Shutting Down the Sweeper

When you are finished sweeping, use the following steps:

1. Set the engine throttle to idle.
2. If the curb brooms are in use, stop their operation and retract them into the travel position.
3. Raise the sweeping hood completely to provide maximum ground clearance.
4. Turn 'OFF' the dust suppression system.
5. The sweeper warning and flashing lights should be turned to the 'OFF' position.
6. Turn the sweeper's power switch to 'OFF'.

I. Dumping the Hopper

The hopper should be dumped when it is full, or after sweeping has been finished for the day. Hopper dumping instructions are as follows:

1. Back the sweeper up to a suitable dumping area. Always dump on level ground and never dump over an open pit or dock.
3. Put the truck in 'PARK' and engage the emergency brake.
4. To raise the hopper:

When this switch is pushed, a sequence of functions takes place. First the door latches open and unlock the door. When the door latches are fully open they trigger a proximity switch that redirects the pressure oil to the hopper lift cylinders and door open cylinders. Second the door and hopper will begin to lift. This prevents the door from being closed and latched when the hopper is being lifted in case the load was to shift and put excessive force on the door causing failure of the door and hinges.

5. If you plan to have the hopper raised for longer than the time needed to dump the debris, place the safety chocks on the dump cylinders. This also applies for when the hopper is being washed out or any other time you may have it in the raised position.
6. If the safety chocks were used, remove them and make certain the area under the hopper is clear.
7. To lower the hopper:

When this switch is pushed, a sequence of functions also takes place. First the hopper comes down and the door closes. Once the door is closed it triggers a proximity switch which redirects the pressure oil to the door latch cylinders. This ensures the door latches do not close before the door is closed causing the latches to miss the latch rod that holds the door in the closed position.

J. Dual Steering

The dual steering components in the truck consist of integral, or a “cross shaft,” design.

This allows the driver/operator to operate the sweeper from the driver, or passenger side, of the vehicle. **The driver/operator should only drive from the passenger side at slow speeds and only while actually sweeping.**



WARNING! Drive/travel from the left side only.

To operate the dual steering you must have the truck completely shut off then switch the toggle switch toward the desired operating side.

(Photo shown with the switch in left side operation mode. Press to the right for passenger- side operation mode. Make sure the chassis switch is completely off before doing the swap. Failure to do so could engage the check engine light.)

Integral steering: Integral steering is set up to provide you the most ‘factory feel’ of operation. It has the ability to tilt and telescope the steering wheel for more comfort!

Cross shaft steering: Cross shaft steering has a shaft that goes in between the two steering columns. You will not be able to adjust the steering wheels in any way with this design.



K. 12-VoLt Backup System

If your sweeper is equipped with the optional 12-volt back-up system follow these procedures for operating instructions.

1. Turn the console main power switch to the ON position.
2. Locate the switch on the top row that has 'Auxiliary Hydraulics' labeled on it.
3. Press and hold this switch down while pressing the desired switch/function.
4. This 12-volt system is a true backup and will run all hydraulic operations.

WARNING! Do not operate 12-volt pump for more than a minute; it is designed only to operate the system in case of a breakdown!



L. Rapid Reference Operating Outline

1. Check the truck engine and sweeper engine for the correct crankcase oil and coolant levels.
2. Fill the water storage tank.
3. Start the truck engine and check the control panel for the correct switch settings.
4. Crank the sweeper engine.
5. Let the engine warm-up to operating temperature before sweeping.
6. Turn 'ON' all warning lights and flashers.
7. Lower the sweeping hood to the pavement.
8. Throttle to desired sweeping RPMs.
9. Start the dust suppression system.
10. Turn on the curb broom if it is to be used.
11. Put the truck in gear and begin sweeping.
12. Avoid surface obstacles.

M. Recommended Operating Equipment

Whenever the sweeper is being operated it should be equipped with emergency equipment and hand tools. In the event of a breakdown or if you need to remove large debris, you will need safety devices. We recommend the following items, which may be adapted to suit your specific needs:

- Shovel
- Rake/Hoe
- Heavy Push Broom
- Gas Can
- Tools/Toolbox
- Flashlight
- Safety Flares
- Jumper Cables
- Water Hose (to fill water tank)
- Backpack Blower (oil/gas mix)
- 2-cycle Oil (for blower)
- Quart of Oil
- 2-3 Cans of Tire Puncture Repair
- Spare Tire
- Fire Extinguisher
- 2-5 Ton Hydraulic Bottle Jack

V. General Sweeper Maintenance Checks

This information is to be used in combination with your truck chassis and auxiliary engine Owner's Manuals. You will need to refer to each manual for specifics on maintenance schedules and procedures for this unit.

When you are using the sweeper on a daily basis you will need to do a walk around inspection prior to each operation. One of the best times to do this is when you are filling the water tank or whenever the hopper is raised. Here are examples of what to look for:

1. Are any of the belts loose or frayed?
2. Do all the seals look tight? Is the dump and side doors tight?
3. What condition are the fan and suction seals in?
4. Check all the fluid levels and replenish as necessary.
5. Look at the air filter's air restriction indicator. It is located on or near the auxiliary engine's air filter canister. Has the 'need to service' window changed colors? If it has changed, then change the air filter.
6. Inspect the curb brooms for bristle wear and any leaking hydraulic oil on the hoses or fittings.
7. Are the curtains or flaps properly adjusted? Do they need replacing?
8. Is the sweeping hood rested properly on the ground?
9. Are all the safety shields and guards in place and in good working condition?
10. Check for any loose bolts, worn or broken parts, leaky or loose fittings, or pinched hydraulic hoses.

Performing any needed repair of the sweeper components prior to traveling to the sweeping location saves time and is much easier when you have the proper tools available.

R-6 Maintenance Filter Cross Reference

Filter Manufacturer	KUBOTA	DONALDSON	FRAM	CARQUEST	BALDWIN	ZINGA		
small hyd. oil filter	1416	P551551	P1653A	85259	BT839-10	AE-10		
V3700								
engine oil	2261	HH1C0-32430	P550318	PH10968	84430	B7298		
outer air filter	2267		P828889	CA8737	88562	RS3544		
inner air filter	2268		P829333	CA8737SY	88569	RS3545		
fuel filter	1108	16631-43560	P502163	P9458	86398	BF7967		
ISUZU CHASSIS (2011)							ISUZU	FLEET VALUE
engine oil	1268		ELF7947	HPH3690FP	84521	BD7169	97780196	2-94561-103-0
air filter	1269		P543614	CA9856	88932	RS5434	97779878	5-87610-020-0
automatic trans.							97780203	2-94561-102-0
fuel filter - engine mounted							97780136	2-94561-104-0
fuel filter - frame mounted							97780135	2-94561-106-0
Isuzu maintenance kit - includes - all filters, gaskets, wiper blades and reminder label.							97780217	2-90201-103-0

A. Lubrication Maintenance Schedule

Item	FREQUENCY	LUBRICANT
Truck chassis and engine	Refer to truck Owner's Manual	Refer to truck Owner's Manual
Change auxiliary engine oil & filters	Refer to auxiliary engine Owner's Manual	Refer to auxiliary engine Owner's Manual
Fan shaft bearings	Every 250 hours of operation	Grease with lithium-based grease, one pump from a hand-operated gun. DO NOT over-grease or use a power gun
Curb broom arm joints	Every 120 hours of operation	Grease with a Lithium-based grease.
Fan and intake seals	As required	Lubricate with a rubber protectant, petroleum jelly or grease to prevent drying and loss of resilience.



B. PERIODIC MAINTENANCE SCHEDULES

The Daily and Weekly Maintenance Schedules list specific items and areas that need to be inspected. The items listed cover the main areas that must be checked; however, it is not a complete list.

The Daily and Weekly Maintenance Schedules have been designed so that you may make copies and keep a record of when the sweeper was inspected and by whom.

B1. DAILY MAINTENANCE (EVERY 8 HOURS OF OPERATION)

WARNING: Remove chassis keys and/or disconnect the chassis battery cable when checking the fan housing liner or the fan.

TRUCK SWEEPER HOOD Check the air filter. Replace as needed

Check the engine oil and fill to proper level. Refer to Truck Owner's Manual for oil weight & frequency.

Check the fan belts for wear and tension.

Check the tires for excessive wear or objects. Fill to the proper pressure.

Check the radiator coolant and fill to level. Check hoses for cracks.

Fill the fuel tank as needed. Keep track of gallons used each day.

Check transmission fluid with the engine running. Fill as needed.

AUXILIARY ENGINE CURB BROOM Check oil level. Fill as needed. Refer to Auxiliary Engine Manual

Check belt alignment, tension and wear.

Check radiator coolant level. Refer to Auxiliary Engine Manual.

Clean radiator cooling fans and frontal area as necessary.

Check the air restriction indicator window replace the filter's dry element if window shows 'need to service'.
DO NOT BLOW OUT THE ELEMENT.

WATER SYSTEM Flush 'Y' strainer with water and fill water reservoir. Inspect all water nozzles for proper operation. If not operating, disassemble & clean or replace filters.

SWEEPER HOOD Check runners for wear and replace. If worn 80% of the way through.

Check for holes, tears or uneven

ground contact when the hood is down. Adjust chain length or replace.

Check drag arm bolts for wear. If worn into bolt shoulder, replace with common grade of same size.

Check intake & exhaust hoses for wear and replace if holes or tears are present.

HOPPER SCREEN

Rinse out with water.

DRIVE BELT

Check tension & wear. Tighten if deflection is greater than 1/2". Replace if worn.

FAN & INTAKE TUBE SEALS Check for wear & tears. Replace if they do not seal properly. Lubricate with petroleum jelly or equivalent.

CURB BROOM

Fill hydraulic reservoir as needed. Adjust disc angles as needed to compensate for wear.

INSPECTED BY: _____

DATE: _____

B2. WEEKLY MAINTENANCE (EVERY 40 HOURS OF OPERATION)

WARNING: Remove the chassis keys, turn off optional safety disconnect, and/ or disconnect the auxiliary engine's negative battery cable when checking the fan housing liner or the fan.

Item	Maintenance
Fan	Check for wear of the blades and replace if worn through.
Fan Housing Liner	Check for wear and replace at first signs of holes.
Fan Housing Liner Bolt	Check the heads for wear and replace as needed
WATER SYSTEM	Drain the water reservoir. Remove and clean the screen inside the 'Y' strainer.

INSPECTED BY: _____

DATE: _____

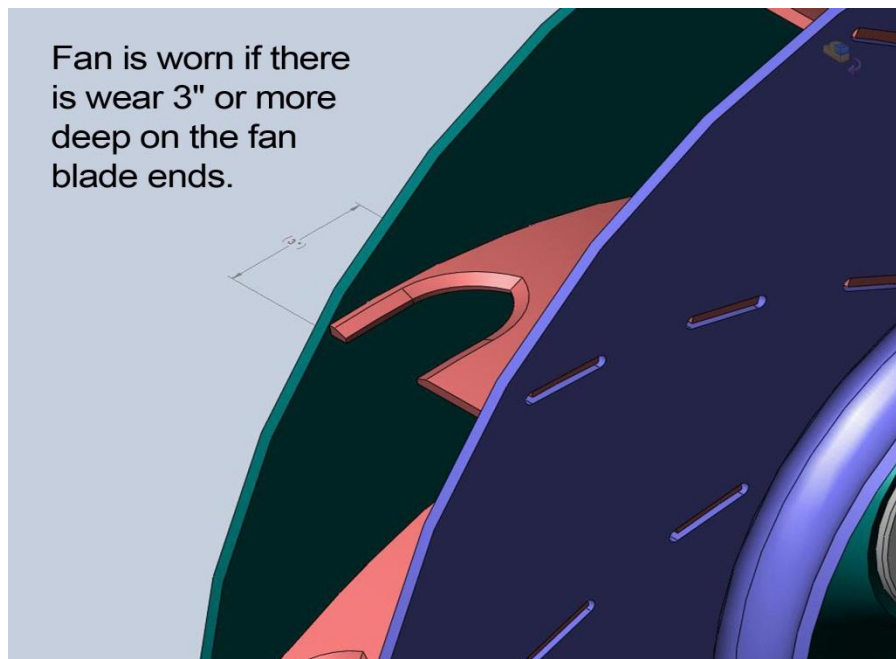

C. COMPONENT MAINTENANCE PROCEDURES

C1. CLEARING OBSTRUCTIONS FROM THE INLET TUBE

1. Locate the sweeper in an area conducive to safe work practice. Make sure the sweeper is parked with the brakes set and that the engine is off.
2. Remove all keys (chassis and console).
3. Remove the band clamp from the bottom end of the flexible intake tube, which is connected to the sweeping hood. Clear the tube of obstructions from the lower end.



CAUTION: be extremely careful when cleaning the inlet tube, as sharp objects such as metal, glass, hypodermic needles, hazardous materials, etc., may be present. Be sure to wear appropriate protective equipment!

4. Reconnect the flexible intake tube and tighten the band clamp to the sweeping hood. Check for proper operation before continuing.



WARNING: Do not raise the hopper in an attempt to clear the obstruction from the top of the suction tube. Doing this can create a crushing injury between the hopper and the top of the suction tube.



C2. CLEANING MAINTENANCE

To keep your sweeper operating at its peak performance it is imperative that you clean it daily. Dirt and grime are much harder to remove once they have had a chance to build up and bond to surfaces. Daily debris collects and adheres rapidly, decreasing airflow, blocking water nozzles, and causing unnecessary wear. You will maximize the life of the components by cleaning the sweeper as often as possible.

C2a. Cleaning Procedures

1. Spray-wash the outside and the underside of the sweeper and truck cab. Be sure to remove rust-causing road grime.
2. Clean out the inside of the truck cab, removing any items not required during sweeping operations.
3. Clean windows and mirrors for maximum visibility.
4. Dump the hopper contents.
5. Open the side inspection doors and spray wash with the maximum water pressure available.
6. Raise the hopper for a final wash through the open doors. Pay special attention to corners and seams.
7. Wash the sweeping hood, inlet hoses and tube, both inside and out.
8. When you have completed the washing leave the hopper inspection doors to the inside open to let it dry as soon as possible.
9. If practical, leave the hopper raised an inch or two in order to relieve the pressure against the fan and intake seals. This allows the seals to regain their shape and provide longer wear for them.

C3. STORAGE MAINTENANCE

The importance of proper storage and maintenance care cannot be over emphasized. Your sweeper is the core of your business and with the proper care it will provide the service needed. The day-to-day maintenance recommendations should be followed in order to correct any minor problems before they become costly repairs.

If you need to store the sweeper for any extended period of time it is recommended that you store it inside an enclosed building. Always raise the hopper an inch or two. This will relieve the pressure against the fan and intake seals allowing them to regain their shape. Open the inspection and dump doors.

The sweeper is designed to withstand exposure to the elements. If inside storage is not an option, a canvas cover for the entire sweeper can be used to protect rust-prone components, such as the sweeper engine muffler and the throttle linkage. When storing the sweeper outside leave the inspection and dump doors closed.

C4. AUXILIARY ENGINE MAINTENANCE

Your Stewart-Amos Sweepers R-Series sweeper is equipped with a four-cylinder, water-cooled diesel engine. The information in this section is intended to be used in conjunction with your auxiliary engine Owner's Manual. Be sure to read it for specifics on maintenance schedules and procedures required for this unit.

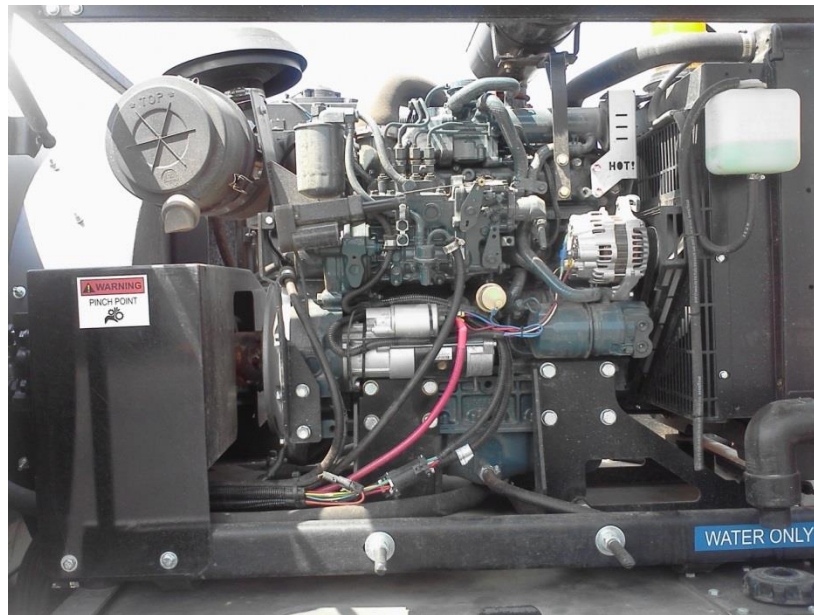

C4a. Maintaining the Kubota Fuel Filter

The fuel filter on the Kubota V3307 is located in-line between the fuel pump and the injector pump at the back of the engine cylinder head. The fuel filter is located on the passenger side of the auxiliary engine. **When filter replacement is needed** follow the instructions listed below:

1. Before unscrewing the fuel filter, make sure the sweeper engine key is in the 'OFF' position. If the key is in the 'ON' position the electric fuel pump will be supplying fuel to the filter as you attempt to remove it.
2. Once the key is in the 'OFF' position, unscrew the filter from the filter head.
3. Remove filter from the bottom; dispose of it properly. Fill the new filter with clean fuel before installing. Reverse the process, inserting the new filter from the bottom, tighten hand tight only.
4. The fuel filter head's bleeder valve should then be loosened so that air may be removed from the filter. The bleeder valve is located on the main injection pump of the auxiliary engine. While bleeding the fuel system the sweeper engine key should be 'ON'.
5. Prior to restarting the engine, use the primer pump mounted on the side of the main injection pump. Pump for approximately 4 minutes. This will remove any air left in the filter and lines to the injection pump.
6. Re-tighten the bleeder valve. The auxiliary engine is now ready to be started.

C4b. Auxiliary Engine Remove and Replace

The sweeper's auxiliary engine is built to provide years of service when maintained properly. Following the maintenance guidelines and schedules will prolong the performance; however, it is still subject to wear. At some point in time, the auxiliary engine may require removal so that it may be serviced or replaced. Use the following guidelines for this procedure:

1. Remove the sweeper engine battery cable to prevent the engine from being accidentally started.
2. Tilt the cab forward to gain additional working area.
3. Remove the belt guard.
4. At this point, you are ready to disconnect the wires that prevent the removal of the engine from the mounting skid. Before disconnecting any of the wires, wrap a piece of masking tape on each wire. As you disconnect them, label each wire with a marker in the order that you disconnect them. This will simplify the re-connection process upon reassembly.
5. Unplug the engine harness and disconnect the starter cables.

6. Make sure that all the disconnected wires are tied or secured in order to prevent any of them catching as the engine is removed.
7. Disconnect the throttle cable and make sure it is clear from the engine.
8. Disconnect the fuel line. Bend the end back upon itself and tie it with wire or tie-wrap to prevent fuel from leaking.
9. Remove the two front engine leg mounting bolts that hold the front leg to the power module.
10. Remove the two, rear engine leg mounting bolts that hold the rear leg to the power module.
11. Use the jackscrews to push the engine toward the center of the truck, loosening the drive belt. DO NOT pry against the oil pan as it will crack the pan and void the warranty.
12. Remove the outside sets of jackscrew jam nuts and jackscrew nuts.
13. Remove the jackscrew nuts and threaded rods from the side of the engine legs.
14. Remove the fan drive belt from the engine pulley.
15. Disconnect the hydraulic hose from the engine-mounted pump. Secure the hoses so that the hydraulic fluid does not drain out.
16. If the sweeper is equipped with a tachometer or other devices, disconnect them from the engine at this point.
17. Use a hoist to slowly lift the engine out and away from the sweeper.
18. Transfer the engine legs and brackets to the replacement auxiliary engine.
19. To insert the replacement auxiliary engine, follow the steps 1 through 16 in reverse order.
20. Once you have finished with these steps, follow the procedures outline in 'DRIVE BELT ADJUSTMENT'.

C4c. Auxiliary Engine Stub Shaft Remove and Replace



It is rare to have a stub shaft fail; however, as with any component, it may need to be replaced at some point. Some of the causes are:

- An over-tightened drive belt creating too much side load
- warping or grooving of the stub shaft caused by a failed bearing
- cracking or warping of the stub shaft caused by torque created by the sudden stop of the fan's drive train.

To replace the stub shaft follow the instructions below:

1. Turn off the sweeper power switch and/or disconnect the battery cable to prevent the sweeper engine from being started by accident.
2. Loosen, but DO NOT remove, the engine leg mounting bolts and nuts that hold the auxiliary engine legs to the engine skid.
3. Turn the jackscrew nuts so the engine is pushed toward the fan shaft.
4. The drive belt will become loose enough to be slipped from its pulleys as the engine skid moves towards the fan shaft.
5. Remove the 3/8" bolts and lock washers from the stub shaft pulley bushing.
6. Insert two of the 3/8" bolts into the two tapped holes of the stub shaft pulley bushing.
7. Tighten the bolts evenly by alternating from one to the other until both are tight. This procedure will push the pulley off the stub shaft pulley bushing.

8. Remove the pulley and its bushing from the stub shaft.
9. Remove the bearing plate from the end of the auxiliary engine. Look for any irregularities in the bearing plate. If you do not find any, you may use the bearing plate again.
10. Remove the old stub shaft from the end of the auxiliary engine.
11. Clean the flywheel and the replacement stub shaft using lacquer thinner.
12. Fasten the replacement stub shaft to the auxiliary engine using 32 ft. lbs. of torque on each bolt.
13. Use a dial indicator to ensure that the stub shaft is in line with the crankshaft. The stub shaft cannot be more than .007" off-center or it must be replaced.
14. Put the replacement bearing onto the end of the stub shaft. Use a piece of pipe, placed over the stub shaft's end, to drive the bearing down the stub shaft until it rests against the seat.
15. Slip the bearing plate down the stub shaft and onto the bearing.
16. Bolt the bearing plate to the auxiliary engine.
17. Slide the stub shaft pulley and its taper-lock bushing onto the end of the stub shaft.
18. Insert the bolts, through the taper-lock-bushing flange, into the pulley. To make sure the pulley is pulled onto the bushing evenly, alternate turning the three bolts.
19. Check the alignment of the pulley. To do this, use a string or straight edge from the face of one pulley to the face of the other. The pulleys should be in-line with each other. If this is not the case, back the stub shaft pulley off its bushing, move both in the proper direction for alignment, and then retighten the bushing/pulley bolts.
20. Inspect the drive belt for wear and replace it with a new one if needed.
21. Slide the drive belt onto the stub shaft and fan shaft pulleys.
22. Adjust the drive belt tension as outlined in the 'DRIVE BELT TENSION ADJUSTMENT' section.
23. Replace the belt guard.

C5. BOLT CHECK MAINTENANCE

All the mounting bolts on the sweeper, especially those on the engine and the fan housing, need to be inspected periodically. Due to the vibration of the sweeper's engine bolts can loosen or shear off. If any of the bolts are worn into the shoulder, replace them with a grade five (minimum) bolt of the same size. The following is a list of bolts that should be checked regularly:

Fan Housing and Engine Bolts

- Fan housing mount
- Motor mounts to the engine skid
- Sweeper engine to the engine legs
- Bearing mount

Other Mounting Bolts

- Curb broom mounts
- Water pump
- Hydraulic pump
- Hydraulic reservoir
- Sweeping hood drag arms

C6. CURB BROOM MAINTENANCE



For the curb broom hydraulic system, follow the procedures outlined for the curb broom in the 'Periodic Maintenance Schedules' and in 'Sweeper Fluid Maintenance' sections.

C6a. Curb Broom Disc Adjustment

The curb broom is designed to be full floating. This means it will give way and 'float up' when it runs up against an obstruction. It will also automatically 'float' down to keep the broom in contact with the sweeping surface as the broom bristles wear. Two adjustments can be made to improve the sweeping efficiency on irregular surfaces such as deep gutters.

Adjusting the boom disc should be done while the head is spinning and the bristles are touching the sweeping surface. This bristle-to-ground contact is called the 'curb broom pattern'. The two adjustments allow the operator to control which part, and how much, of the broom touches the sweeping surface. A general guideline for setting the curb broom pattern is to obtain a 9:00 to 1:00 bristle-to-ground contact on the left curb broom, and an 11:00 to 3:00 bristle-to-ground contact on the right curb broom. These patterns will efficiently remove material from the gutter and 'throw' it under the sweeper's sweeping hood.

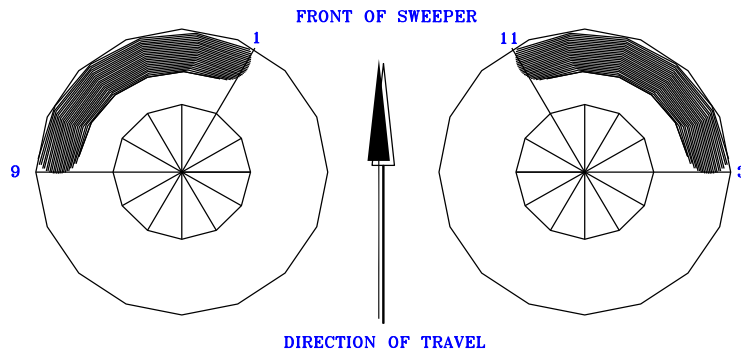

The side-to-side tilt of the broom disc can also be adjusted so as to fit the 'pitch' of the sweeping surface. This is done by an electric actuator, which is operated by the broom tilt switch located on the control panel located in the cab. The actuator may be extended or retracted, which in turn changes the broom disc tilt.

The front-to-back angle of the broom disc is controlled by a turnbuckle that runs between the broom linkage mounting bracket and the top of the broom motor mount.

This must be adjusted by hand. Loosen the jam nut on the turnbuckle that keeps it from self-adjusting, and insert a large screwdriver or wrench into the center to use as leverage. Turning the center shortening the turnbuckle which lowers the nose of the broom disc. Lengthening the turnbuckle raises the nose. When you have finished the adjustment, run the jam nut back tight against the turnbuckle so that it will not self-adjust during broom operation.

C6b. Curb Broom Down Pressure Adjustment



Using the turnbuckle on the left of the above picture, the down pressure of the curb broom can be increased by lengthening the turnbuckle or decreased by shortening the turnbuckle.

C6c. Bristle Replacement

1. To disassemble the curb broom, locate and loosen the four bolts on the top of the broom head. This will free the broom bristle segments.
2. To replace the curb broom, position the new broom bristle segments, line up the bolt holes and tighten the four bolts that hold each segment in place.



C6d. Directional Valve Check

Hydraulic fluid flow is used to control the various functions of the curb broom such as raising, lowering, retract, extend and broom disc rotation. It is the job of the directional valves to determine the flow direction. If the directional valve is not operating correctly and is unable to reverse the hydraulic flow, the curb broom cannot operate properly.

This hydraulic system uses a series/parallel manifold. Which mean that the cylinder functions are on the left side of the manifold and work in parallel with each other. The motor functions are on the right side and in series with each other. Between the two distinctly different sections of the manifold there is a dump valve. This dump valve is located in the third valve position from the right and the 6 valve position from the left. If any function is activated it must also activate one side or the other side of this dump valve. This allows the sweeper to sweep with one curb broom or the other or both.

Manual Override Checks

Any function in this hydraulic system can be overridden manually. Because this system is a series/parallel system there are 2 valves that need to be overridden for any one function to operate. Each function on the valve electrical harness is clearly labeled with the function description. When overriding a cylinder function DUMP VALVE #1 also needs to be overridden at the same time and if it is a motor circuit that is being overridden then DUMP VALVE #2 also needs to be overridden at the same time.

At the center of each coil on the directional valves is a small brass button (as shown in the picture below). By pushing these buttons with a small screw driver, with the engine running, each function can be overridden.



CAUTION: When overriding any function, make sure you or any bystanders are clear of the equipment being overridden.

C6e. Hydraulic System Servicing

CHECK THE HYDRAULIC OIL DAILY AND LOOK FOR LEAKS IN HYDRAULIC HOSES AND FITTINGS!

If a leak is detected, repair it immediately to avoid hydraulic fluid leakage or dirt entering the system. This is a maintenance priority as the hydraulic system is vital to the daily operation of your sweeper. The level should be maintained at the 80% mark on the sight gauge, which is located on the front of the reservoir.

Follow the instructions under 'SWEEPER FLUID MAINTENANCE' for proper oil recommendation and change schedule. Also, follow the filter instructions under 'FILTERS MAINTENANCE.'

Leak Check

1. Check the hoses and fittings regularly for any signs of leakage. Most leaks will not cause immediate failure; however, once a leak has begun it will get worse. Repair all leaks as soon as they are discovered. First, try to tighten the fitting responsible for the leak. If this does not correct the problem, follow the instructions below.

Repair

1. Disconnect the leaking fitting.
2. Clean the seating surfaces.
3. If necessary, a sealing agent can be used on the non-JIC fittings. Use a sealing agent only on the upper threads of the non-JIC fittings to prevent contaminating the hydraulic fluid. The control valve orifices are so small that even minute pieces of debris can block them causing hydraulic problems.
4. Retighten the fitting.
5. Refill the hydraulic system with fluid as needed.



CAUTION: Do not use sealing agents on JIC or SAE fittings. On SAE fittings, always use hydraulic oil.

Directional Valve Configuration

(From left to right)

1. Position #1 is hopper raise/lower
2. Position #2 is left hand curb broom raise/lower
3. Position #3 is right hand curb broom raise/lower

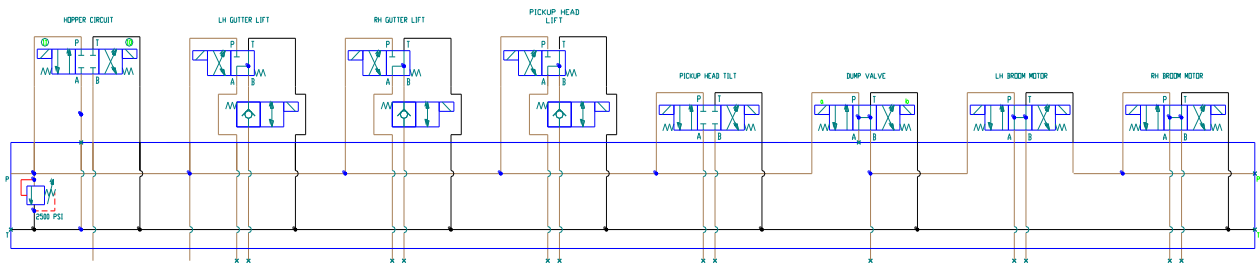

4. Position #4 is pickup head raise/lower
5. Position #5 is pickup tilt up/down
6. Position #6 is the dump valve
7. Position #7 is left hand curb broom fwd./rev.
8. Position #8 is right hand curb broom fwd./rev.

C6f. Hydraulic Pump Pressure Check

Whenever the hydraulic cylinders and hydraulic motors will not function properly, there could be a problem with the hydraulic pump pressure. To check this problem, follow the instructions below:

1. Before making adjustments, check the electric and hydraulic system for any loose connections. The electrical connection to each solenoid is opaque. This is for diagnostic purposes. When a function is activated on the control panel the connector on the corresponding valve solenoid will light (red). This will determine if the problem is an electrical issue (connector is not lit) or a hydraulic issue (if connector is lit).
2. Check the hydraulic fittings and hoses for leaks.
3. Check the fluid for contamination and proper fill level.

DO NOT increase the pump pressure to compensate for leaking hoses, loose fittings, contaminated fluid or a clogged filter, as this can cause damage to the pump and other sweeper components. Once you have made all possible hydraulic checks and you still believe there is a problem causing low fluid pressure from the pump, the pump's fluid pressure may be verified with help from another person. Follow the instructions below:



Pressure Test Gauge

Verify Hydraulic Pump Fluid Pressure

1. On each sweeper there is a 0-5000 psi pressure gauge attached directly to the pressure port on the manifold. Just below the pressure gauge is a small hand valve. This hand valve protects the gauge when it is not required. Open the hand valve 1 full turn for activating the gauge. Once the valve is opened with the engine off the gauge should read 0 psi. If the gauge is reading any pressure then the gauge must be replaced to get an accurate reading.
2. Start the auxiliary engine and throttle up to approximately 2100 RPM.
3. Have the second person hold the sweeping hood in the 'raise' position and continue to hold the switch in this position even after the sweeping hood is fully raised.
4. Check the pressure gauge. It should read 2300 - 2500 psi while the switch is being held in the 'raise,' position.
5. If the pressure gauge readings are not within this range you may need to adjust the pressure relief valve.



Pressure Relief Valve

System Pressure Relief Valve Adjustment

1. Locate the relief valve. It is screwed into the top of the manifold block.
2. Loosen the relief valve stem's jam nut. Screw the relief valve stem in (clockwise) to increase the fluid pressure, or out (counter clockwise) to decrease pressure.

Do not turn the adjustment stem more than 1/8 of a complete revolution at a time.

Do not exceed the 2500 psi maximum pressure at 2100 rpm. Excessive pressure will damage components.

3. Once the pressure has been set to the correct reading turn off the auxiliary engine and close the hand valve below the pressure gauge.

C7. Drive Train Maintenance

Follow the instructions in this section for replacement and servicing of the major components of the fan's belt drive and components.

C7a. Drive Belt Tension Adjustment

During the sweeper's break-in period the drive belt will stretch noticeably. To prevent premature belt wear and maintain performance, it must be adjusted. After the first adjustment you will need to periodically check the drive belt for proper tension and to compensate for belt stretch. When the drive belt is properly adjusted, it should deflect downward approximately 1/2-inch at the midpoint between the two pulleys.

Before making this adjustment it is important to understand how the auxiliary engine is mounted, since the tension on the sweeper's drive belt is adjusted by repositioning the auxiliary engine.

The auxiliary engine is fastened to an engine cradle, which is mounted to the power module. To reposition the engine the nuts and bolts, which hold the auxiliary engine cradle to the power module, must be loosened. The engine cradle is attached to the power module by four bolts. In addition, two jackscrews, used for loosening and tightening the drive belt, are located on the left side of the engine.

The jackscrews are held in place by a set of jam nuts, as well as nuts located on each side of the engine skid wall through which they pass. When the inside set of nuts is loosened and then the outside set tightened, the auxiliary engine is repositioned away from the fan shaft. When the outside set of nuts is loosened, and then the inside set tightened, the auxiliary engine is repositioned toward the fan shaft.

Adjustment

1. Turn off the sweeper power switch and/or disconnect the battery cable to prevent the engine from starting accidentally.
2. Before beginning this procedure, mark the engine's position with chalk or a grease pencil. Mark where both front and rear is located on the power module. This is your starting point. Next, measure back 1/4-inch from the first mark and make another mark, which is to indicate the amount of adjustment needed. By marking both the front and rear locations you will ensure that the adjustment is done evenly. The 1/4-inch adjusting mark is only a guideline. Always adjust the drive belt tension to the correct deflection specifications.
3. Loosen (DO NOT REMOVE) the engine leg mounting nuts and bolts that hold the auxiliary engine legs to the engine skid. Also, loosen the 9/16" nut located between the mounting bolts on both the front and the rear.
4. Loosen the inside set of jackscrew nuts and tighten both outer sets. Alternate from front-to-rear until the engine is to the adjustment mark.
5. Check the drive belt's tension. The belt should be adjusted so that it deflects 1/2-inch at the midway point between the pulleys. If the belt is too loose, repeat step 4. Do not over tighten the belt.



6. Check the alignment of the pulleys with a straight edge or, alternatively, a string placed across the front faces of the pulleys. If they are misaligned, the jackscrews may be used to manipulate the auxiliary engine's position relative to the fan shaft and bring the pulleys into correct alignment. However, if this is done then steps 4 and 5 must be repeated.

NOTE: If pulleys are misaligned, it will cause the belt to wear unevenly and reduce performance.

7. Tighten the inside set of jackscrew nuts.

8. Retighten the four engine mounting bolts and the two slide-bar retaining nuts.

9. Reconnect the battery cable and/or insert keys.

10. Start the sweeper engine. Squealing or unusual vibrations indicate low drive belt tension. Adjust as needed.

C7b. Drive Belt Replacement

Drive belts become worn with normal use. We recommend that you replace the drive belt when it shows signs of wear. If you wait until it breaks, it will probably occur at a time that will create sweeper downtime. Replacing it before it breaks also assures optimum sweeper performance.

To replace the drive belt the sweeper engine will need to be repositioned. Review the 'DRIVE BELT TENSION ADJUSTMENT' section before you continue, as it will explain the mountings.

Also, before you begin this process, inspect the belt pulley for any excessive wear, nicks, or burrs. If any irregularities are found, you will need to replace the pulleys.

Removal Instructions

1. Turn off the sweeper power switch and/or disconnect the battery cable to prevent the sweeper engine from starting accidentally.

2. Loosen (DO NOT REMOVE) the mounting nuts and bolts on the sweeper engine that hold the cradle to the power module and the slide bar retaining nuts.

3. Loosen both sets of the outer jackscrew nuts, front and rear.

4. Slide the engine toward the center of the truck. If a pry bar is needed, DO NOT PRY AGAINST THE OIL PAN. This may cause permanent oil leaks and will void your warranty.

5. Slip the drive belt off the engine and fan shaft pulleys.

Replacement Instructions

1. Check the pulley grooves for burrs or any other irregularities that may cause abnormal belt wear. Correct if needed.
2. Position the replacement drive belt on its engine and fan shaft pulleys.
3. Loosen the inside set of jackscrew nuts and tighten both outer sets. Alternate from front to rear until the engine has been repositioned away from the center of the truck and the belt is reasonably tight.
4. Check the drive belt tension. Adjust the belt so that it deflects 1/2-inch at the midway point between the pulleys. **DO NOT OVERTIGHTEN THE BELT.** If the belt is too loose, repeat step 3.
5. Check the alignment of the pulleys with a straight edge or string. Place it across the front faces of the pulley. If the pulleys are not in line, the jackscrews may be used to manipulate the auxiliary engine's position relative to the fan shaft, which should bring the pulleys into line. Then, repeat steps 6 and 7. Misalignment will cause the belt to wear unevenly and reduce performance.
6. Once you have made the proper adjustments, tighten the inner set of jackscrew nuts, front to rear.
7. Tighten the engine leg's mounting nuts and bolts and the slide-bar retaining nuts.
8. Reconnect the battery cable and start the sweeper engine. If you hear any squealing or feel abnormal vibrations, this means the drive belt tension is too low. Adjust, if needed, by repeating from step 6.

C8. Fan Housing Maintenance

The fan housing directs the flow of air from the fan to the sweeping hood. To provide maximum performance it should be checked for wear on a regular basis.

C8a. Fan Housing Inspection

A small amount of fine dust is pulled into the fan chamber when air is drawn from the hopper into the fan housing. This fine dust wears the fan blades, fan housing liner and the heads of the fan housing liner bolts. Over time, this sandblasting effect of fine dust will eventually wear out the components and they will need to be replaced.

A worn fan blade can break and damage the inside of the fan housing, which is both dangerous and costly. Worn liner bolts may allow the fan housing liner to sag, causing damage to the fan as well as to its shafts and bearings.



Also, a worn liner permits the sandblasting effect of the air stream to reach the walls of the fan housing, which is an expensive item to replace.

Inspection Procedure:

1. Raise the hopper and place the safety chocks on each of the dump cylinders.
2. Turn off the sweeper power switch and disconnect the battery cable to prevent it from accidentally starting.
3. Remove the back plate.
4. Use a flashlight to inspect the fan blades, fan bushing, the fan housing liner bolts and the fan housing liner.
5. If no abnormal or excess wear is evident, replace the back plate.
6. Remove the safety chocks and reconnect the battery cables.

C8b. Fan Replacement

Any time a worn fan is causing reduced sweeping efficiency, you should replace it immediately. The fan shaft bearings have roughly the same life expectancy and should be replaced at the same time. This is a labor-intensive operation and it is recommended that you replace both components at the same time in order to save time and money from downtime. There are two exceptions to this rule:

1. If you do not use the sweeper's water system or you sweep in extremely sandy conditions, you will have to replace fan more often than bearings.
2. If the proper bearing lubrication procedures have not been followed, you may have to replace the bearing more than the fan. However, in most cases, it is recommended that the fan and bearings be replaced at the same time.

Fan Replacement Disassembly

See the representation below for fan wear description.

1. Raise the hopper and place the safety chocks on each of the dump cylinders.
2. Turn off the sweeper's power switch and disconnect the battery cable to prevent the engine from accidentally starting.



3. Remove the 3/8" lock nuts and washers from around the back cover plate and lift it off.
4. Remove the 3/8" bolts and lock washers from the fan's bushing.
5. Reinsert two 3/8" bolts into the tapped holes of the bushing. Tighten these bolts evenly. This procedure will push the fan off the bushing.
6. Use a gear puller to remove the bushing from the fan shaft.
7. Remove the fan from the fan shaft and fan housing.

8. Once you have the fan out, check the rubber liner inside the fan housing. If you notice excessive wear, replace the liner. Failure to replace this inexpensive liner could result in having to replace the expensive fan housing prematurely. For instructions on this procedure see 'FAN HOUSING LINER REPLACEMENT'.

Replacing the Fan

1. Inspect the end of the fan shaft for damage. Remove any burrs or rust from the shaft end with sandpaper.
2. Place the fan on the fan shaft and push it back into the fan housing.
3. Inspect the bushing for cracks or any other damage. The original bushing may be reused.
4. Apply an anti-seize agent to the tapered area of the bushing.
5. Slip the key into the bushing/fan shaft keyway.
6. Position the fan bushing onto the fan shaft while aligning it with the shaft key as well as the fan. If necessary, spread the bushing apart; however keep in mind that it will crack if it is overspread.



7. Drive the fan bushing onto the fan shaft until approximately 1/4-inch of the shaft extends from the face of the bushing. You may need to use a rubber hammer (or wooden block with metal hammer) to drive the bushing on.
8. Insert the three 3/8" bolts, with lock washers, through the untapped bushing holes and into the tapped holes of the fan. Finger-tighten the bolts. **DO NOT** tighten the bolts so as to secure the fan to the shaft.
9. Apply strip caulk, or a similar sealing agent, to the face of the fan housing.
10. Install the back cover plate. It may be necessary to move the fan and its bushing further into the fan housing before the back cover plate can be mounted. Before you tighten the bolts, pull the fan back until it touches the back cover plate's inlet ring. Using the available slack, center the cover plate's inlet ring in the fan's orifice. Feel around the perimeter of the inlet ring to make sure the gap is even.
11. Tighten the cover plate bolts.
12. Move the fan back onto the fan shaft. An ideal gap distance is 1/4-inch from the cover plate orifice to the narrowest part of the fan's orifice. See the illustration below.
13. Position the fan onto the fan shaft. Keep in mind that as the fan is tightened onto its bushing, it will travel roughly 1/4-inch toward the cover plate's orifice.
14. While holding the fan shaft in position, tap the fan bushing along the fan shaft and into the fan's hub.
15. When the fan bushing is snug inside the fan's hub, insert the 3/8" bolts and tighten the fan onto the fan bushing. As the bolts are tightened and the fan drawn onto the bushing, the fan should move 1/4-inch toward the cover plate.
16. Turn the fan to determine if the two orifices rub as it rotates. If the orifices do not touch, proceed on to step 17. If the orifices do touch, mark the bushing's present location on the fan shaft to provide a reference point. Remove the fan from its bushing and follow steps 13-15 in order to remount the fan further into the fan housing.
17. Once the fan is properly mounted, remove the hopper safety chocks and lower the hopper.
18. Reconnect the battery cable.
19. Start the auxiliary engine and listen for sounds of contact between the cover plate orifice and the fan orifice. If none are heard the unit is now ready to sweep. If any such sounds are detected, raise the hopper and readjust the fan.

C8c. Fan Housing Liner Maintenance

To prevent damage due to air-blasts from the fan, a rubber liner is attached to the inside of the fan housing. Regularly check the liner for pitted areas, tears, holes or worn liner bolts. If the liner is worn, it will expose the fan housing to direct wear. When compared to replacing the fan housing liner, the fan housing is an expensive item to replace.

Fan Housing Liner Replacement

1. Follow steps 1–7 under ‘FAN REPLACEMENT DISASSEMBLY.’
2. Unscrew the 3/8” nuts from around the outside of the fan housing and remove the elevator bolts holding the rubber liner in place. Inspect the condition of the fan housing liner bolts. Any worn bolts should be replaced with new ones upon reinstallation.
3. Remove the worn liner in one piece, if possible. Save it to use as a template to mark the new liner’s hole pattern.
4. Place the old liner on top of the replacement liner material and mark the length and hole pattern with spray paint.
5. Cut the liner material to length and use a drill to make the holes.
6. The replacement liner hole pattern is different at each end. Be sure to position the liner so that its holes match the hole pattern of the fan housing.
7. Start by installing the elevator bolts, which hold the rubber liner to the top of the fan housing. Continue installing the remainder of the elevator bolts, working out and down from the top of the fan housing.
8. Check the fan blades for wear and replace them if needed. To replace the fan, follow steps 1 through 19 of ‘FAN REPLACEMENT.’

C8d. Fan Shaft Bearing Maintenance

If the bearing is requiring replacement frequently, review and adhere to the bearing lubrication section in this manual. When the bearing fails, it is accompanied by abnormal noise(s), vibration and/or grease slinging caused by ruptured bearing seals. If this happens, the worn bearings need to be replaced immediately to prevent damage to other sweeping components. Normally, when replacing the bearing the fan shaft and accompanying drive belts, pulleys and, bushings should also be replaced. Replacing them all at once saves repetitive maintenance and downtime.

On new sweepers, or sweepers that have been exceptionally maintained, only the bearing insert may need to be replaced. However, needing to replace only the bearing inserts is rare. If the bearing casings are not damaged and can be slid off the fan shaft, then the bearing inserts can be replaced. This procedure can only be performed if the fan shaft is free from paint, rust and burrs, or when it has not been otherwise damaged.

Fan Shaft Bearing Lubrication

The two pre-lubricated bearings on the fan shaft should be re-lubricated after 250 hours of operation. Check the sweeper engine's hour meter and lubrication chart to determine when this maintenance is due to be done. Use only lithium-based grease, one conforming to NLGI Number 2 consistency. The grease must be free from any chemical impurities such as free acid and free alkali. It must also be free from physical impurities such as metal, rust, dust, and other abrasive particles. This light-viscosity, low-torque grease is used because of its water-insoluble rust inhibitors and its operating temperature range that makes it chemically and mechanically stable. Its normal operating temperature range of -30 degrees to +250 degrees Fahrenheit is ideal for sweeper operations.

1. Prior to lubrication, run the auxiliary engine to heat up the old grease. Once the bearing grease has warmed, turn the auxiliary engine off and remove the keys.
2. Using a hand-operated grease gun, very slowly apply one pump of grease to the bearing (a small bead should form around the bearing seal when running). This should be about 1/4 ounce of grease. The bead indicates that adequate lubrication has been applied, as well as provides a protective seal against foreign material entering the bearing.

There is generally a slight rise in operating temperature (10-30 degrees Fahrenheit) after the bearing has been re-lubricated. This rise will continue until the grease stabilizes in the bearing chamber. **Never use more than one pump of grease, or grease the bearings more often than every 250 hours of operation.** Over-greasing the bearing will shorten its life through causing the bearing to overheat and fail.

Fan Shaft Bearing Disassembly

1. Raise the hopper and place the safety chocks over the dump cylinders.
2. Remove the sweeper engine battery cable to prevent the engine from accidentally starting.
3. Remove the 3/8" nuts and flat washers from around the fan housing's back plate.
4. Lift the back plate off the fan housing studs.

At this point, two options exist. These are to either remove the fan wheel separately, or to remove it as a unit with the fan shaft. If you choose to remove the fan wheel separately, follow steps 5-9. To remove it with the fan shaft, skip to step 10.

5. Remove the three 3/8" bolts and lock washers from the fan bushing.
6. Insert two of the 3/8" bolts into the tapped holes of the fan bushing.
7. Tighten the bolts by alternating from one to the other. This procedure will push the fan off the fan bushing.
8. Using a gear puller, remove the fan bushing from the fan shaft. The fan shaft key will come off with the bushing.
9. Slide the fan off the fan shaft.
10. Relieve the drive belt tension by following the steps detailed in the removal section of 'DRIVE BELT REPLACEMENT.'
11. Remove the drive belt from the fan shaft pulley and then remove the fan drive pulley from the fan shaft.
12. Remove the two 5/8" bolts from each of the fan shaft bearings.
13. If you are removing the fan wheel with the shaft as an assembly, remove the four fan back plate nuts. Next, remove the fan wheel and the shaft assembly from the fan housing as a unit. If you are removing the fan wheel separately, skip this step.
14. Pull the fan shaft assembly from the power module's shelf. This consists of the fan shaft and the two fan shaft bearings.
15. Wrap the middle of the shaft in a cloth and insert the protected portion in a vise. Using 80-grit sandpaper, use the 'shoeshine' technique to buff any surface irregularities off the parts of the fan shaft over which you will be sliding the old bearings. When you have finished, remove the shaft from the vise.

16. Loosen the lock collars from the fan shaft bearings (older models have setscrews) and slide the fan shaft bearings from the fan shaft. If difficulty driving the bearing from the shaft is encountered, place a soft object (such as a brass bar or pipe) against the inner race. Do not hammer directly on the bearing.
17. If you are replacing the bearing inserts only, skip to that section.
18. Inspect the fan shaft and the fan shaft pulley. If either one is damaged or worn too much for reuse, discard and replace.

Replacement of Fan Shaft and Fan Shaft Pulley

1. Prior to replacing the fan shaft, inspect it for burrs, nicks and rust. If any are found they must be removed. To do this, wrap the middle of the shaft in a cloth and insert the protected part in a vise. Use 80-grit sandpaper to buff off any surface irregularities. Buff using a 'shoeshine' manner. When you have completed this, remove the shaft from the vise.
2. If the old fan shaft and fan shaft drive pulley will not be reused, slide the new fan shaft drive pulley, along with its bushing, onto the fan shaft. Spread the bushing apart if needed. Do not over spread the bushing, as it will crack. If the old fan shaft and fan shaft drive pulley are being reused, some repositioning of the pulley may be required when it is reinstalled. Back the pulley off its bushing to loosen it on the shaft for later repositioning.
3. Loosen the lock collars on the replacement fan shaft bearings.
4. Slip the fan shaft bearings onto the fan shaft. If the bearings do not slip on easily, do not hammer the ends of the inner race. The inner races are soft and will damage easily. If force is needed to position the bearing on the fan shaft, use a brass bar or pipe against the inner race to drive the fan shaft bearing into place.
5. Position each fan shaft bearing on top of the power module's shelf and align it with the mounting holes.
6. Place the two 5/8" bolts, flat washers and lock washers into each bearing. Tighten them down to the power module's shelf.
7. Position the fan shaft in the bearings so that 5" of the shaft extends into the fan housing.
8. Apply a drop of 'Loctite,' or equivalent, to the bearing lock collar screw and tighten it.
9. Position the fan shaft drive pulley's bushing such that when the fan shaft drive pulley is tightened onto it, the pulley is drawn into alignment with the drive pulley of the engine.
10. Insert the fan shaft drive pulley bushing's 3/8" bolts, with lock washers, through the untapped holes of the bushing. Screw them into the fan shaft drive pulley.

11. Inspect the fan for wear and replace it with a new one, if needed.
12. Follow the steps outlined in the 'FAN REPLACEMENT' section of this Manual if the fan wheel was removed separately.
13. Adjust the drive belt tension as outlined in the 'DRIVE BELT TENSION ADJUSTMENT' section of this Manual.
14. Remove the dump cylinder safety chocks.
15. Reconnect the engine's battery cable. Lower the hopper and resume operation with the sweeper.

Bearing Insert Replacement

The fan shaft bearings have been designed to allow for easy insert replacement. Replacing the bearing insert is less expensive than replacing the complete bearing; however, this is not always possible. It can only be done if the bearing can be removed from the fan shaft without any damage to the bearing casing.

1. Follow the instructions under 'FAN SHAFT BEARING DISASSEMBLY,' steps 1 through 17.
2. Remove and save the grease fittings from the top of each bearing case.
3. Remove the locking pin from the pathway below the grease fitting and save this pin.
4. Remove the old insert by prying up one edge of the insert using a claw hammer. The insert will come out of the slots on the rear of the bearing casing. Discard the old inserts.
5. Align the insert recess with the grease-fitting hole of the bearing case.
6. The new insert should slip easily into the slotted rear of each bearing case.
7. The original locking pin will fit loosely into the grease pathway. **The original locking pin must be used, and the pin and insert dimple must be in the proper position before replacing the grease fitting!**
8. Reinstall the grease fitting at the top of the bearing case. 9. Follow steps 1–17 of the 'FAN SHAFT BEARING REPLACEMENT' section of this Manual.

C9. SEAL MAINTENANCE

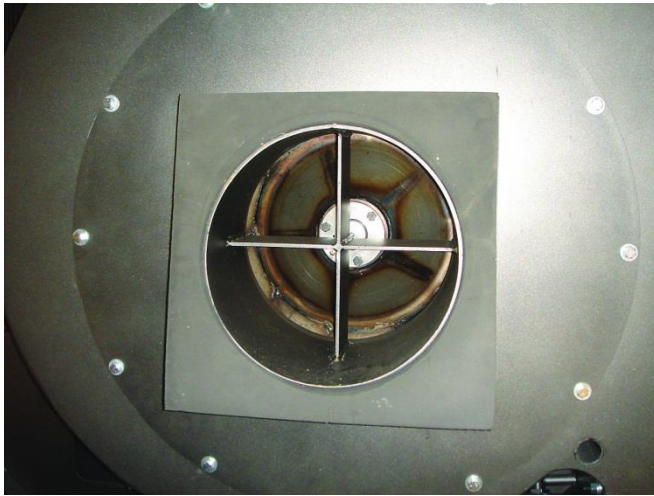

Fan Seal and Suction Hose Intake Seal

Since the sweeper's pickup power is vacuum-dependent, maintaining a tight seal is extremely important. If this seal is not in the best condition possible, it can make a vital difference in the sweeper's ability to pick up debris. The sweeper's seals are located on the fan housing and suction inlet tubes. Lubricate the seals with a high quality grade of petroleum-based jelly or grease to keep them resilient.

The side inspection doors, dump doors and screen access door will not require lubrication.

To extend the life of the seals when the sweeper is parked for an extended period of time, leave the hopper raised a few inches so the fan and intake seals can regain and keep their shape.

Over time, the seals will eventually become worn or non-resilient. When this happens you will notice a loss of vacuum power. To preserve the sweeping efficiency you will need to replace these seals periodically.

To Replace the Seals:

1. Elevate the hopper completely and place the safety chocks on each of the dump cylinders.
2. Pull the seal off of the surface on which it has been mounted. Remove any of the glue particles or remaining seal with a putty knife, sandpaper or grinder.
3. Clean the surface with lacquer thinner or any suitable de-greasing agent.
4. Use a waterproof weather-stripping adhesive that will not dissolve the rubber and apply according the manufacturer's directions. (3M brand adhesive #8001 works well for this)
5. Place the foam seal onto the mounting surface.

6. Make sure the glue dries before lowering the hopper onto the new seal(s). This is to prevent the seals from sliding away from the correct position.
7. Lubricate the new seal(s) with petroleum jelly or grease before using. Maintain lubrication throughout the life of the seal.

C10. SWEEPER ENGINE/FAN RPM CHECK

If the sweeper isn't picking up debris efficiently, the problem may be with the sweeper engine RPM. Every engine RPM is pre-set at the factory, altering the setting will void the engine's warranty. However, to determine if low RPM could be causing the problem, it should be measured to check for poor performance. The fan shaft's RPM should also be measured.

To check the RPM readings it may be necessary to remove the fan belt guard and fan shaft guard. **Be extremely careful while working around the drive belt(s).**

Make these measurements with a suitable tachometer and with the engine at full throttle. If the engine, at full throttle is running at significantly lower than 2800 rpm, check the cable between the throttle actuator and the throttle control shaft on the engine fuel injection pump. If the throttle cable is properly linked to the engine, and the sweeper engine RPM is still low, your engine must be taken to an authorized service center.

If the sweeper engine RPM is correct, but the fan RPM is low, a loose drive belt is indicated. Follow the instructions for tightening the main drive belt in the section 'DRIVE BELT ADJUSTMENT.'

The fan rpm should be approximately 1.35 times the engine rpm or 3750 rpm. Do not tamper with the governor, as this will void the engine warranty! If the RPM readings of both shafts, at full throttle, are close to the tabulated values, then the inefficient pickup is caused by something else. If this is the case, refer to the Troubleshooting section of this Manual.



C11. SWEEPER FLUID MAINTENANCE

C11a. Auxiliary Engine Cooling System

Refer to your auxiliary engine Owner's Manual for the care and maintenance of the cooling system.

C11b. Auxiliary Engine Oil

Refer to your auxiliary engine owner's manual for the manufacturer's suggested oil change schedule and type of oil to use. Use the auxiliary engine's oil drain hose to drain the auxiliary engine oil pan. The hose looks like a hydraulic hose and is located underneath the auxiliary engine. Unscrew and remove the JIC plug, located in the end of the hose, to drain the oil into a container. Be sure to dispose of the oil properly.

Note: For faster and more thorough drainage, you should warm the engine prior to changing oil.

C11c. Hydraulic System

Always maintain the hydraulic oil level at the full mark on the sight level gauge. This gauge is located on the side of the hydraulic reservoir. Change the hydraulic oil after the first 500 hours of operation, then every 2,000 hours thereafter. If the hydraulic oil becomes cloudy, it is an indication that water has contaminated the system and the fluid needs to be changed. Changing the fluid should only be done after you have determined the source of water contamination. **Do not operate the sweeper with contaminated hydraulic fluid.**

At the factory, the hydraulic system is filled with AW 46 hydraulic fluid. Whenever the hydraulic fluid is added to or changed, use this type or equivalent 20-weight (SAE) hydraulic oil.

Note: a system that operates with an ambient fluid temperature greater than 100 degrees Fahrenheit requires 30-weight (sae) hydraulic oil.

C12. SWEEPER FILTER MAINTENANCE



Hydraulic Return Filter



Bushing-Like Suction Filter



Fuel Filter



Dual Element Air Filter 1834

C12a. Auxiliary Engine Filters

The auxiliary engine has three filters: an oil filter, a fuel filter and a dual element air filter. At a minimum, all filters should be changed according to the manufacturer's warranty recommendation. Stewart-Amos Sweeper Co. recommends that the oil filter be changed more often if the sweeper is operated under unusually dusty circumstances. The air filter has a built-in air indicator. This air restriction indicator is usually placed on or near the auxiliary engine air filter canister. When the air filter becomes clogged and needs service, a window on the air restriction indicator changes color. Depending on the type of unit used, the color may change from clear to red, clear to yellow, or yellow to red.

For air filter change and servicing information, see the auxiliary engine's Owner's Manual.

NOTE: Change the air filter ONLY when the air restriction indicator's 'need to service' window has changed color. Air cleaner over-servicing can cause serious engine damage.

C12b. Hydraulic System Filters

The hydraulic tank, which supplies oil to the hydraulic system, has two filters: a suction filter and a return filter. These filters remove from the hydraulic oil any foreign particles that might cause damage to the hydraulic system parts. The suction filter is difficult to locate because the major portion of its body is hidden within the hydraulic tank. The only part that can be seen is the large, bushing-like head protruding from the suction line's tank flange that is positioned at the bottom of the hydraulic tank. The hydraulic tank must be drained before the suction line fittings can be removed. This filter should be replaced after the first 500 hours of operation and then every 2,000 miles thereafter.

To Change the Filter:

1. Locate the hydraulic tank drain hose.
2. Remove the plug.
3. Open the ball valve and drain the fluid into a proper receptacle.
4. Locate the two hydraulic filters.
5. Remove the fittings from the lower suction filter, and then unscrew the filter from the tank.
6. The old suction filter may be discarded and replaced or, depending on its condition, cleaned with an approved cleaning solvent.
7. When you replace the filter, use S-25 suction filters. Screw the suction filter back into its hydraulic tank flange and replace the hydraulic fittings that connect the suction hose to the suction filter.
8. Locate the upper return filter. Unscrew and lift basket filter out.
9. Replace with new filter and replace lid.
10. Refill the reservoir with fresh hydraulic oil at the breather cap to approximately 80% of the full mark on the sight gauge scale. AW46, or equivalent 20W hydraulic oil, should be used.
11. Check the hydraulic oil fluid level after operating the sweeper for a brief period, refilling the system if needed. Perform a thorough leak inspection of the hydraulic fittings on the filters and the curb broom system's hydraulic pump.

C13. SWEEPING HOOD MAINTENANCE

The sweeping hood has been designed to maximize debris pickup via a forced air and vacuum system. Without proper care and maintenance, the sweeping hood cannot provide the necessary and desired sweeping results. (Note: Photos show the Stewart-Amos optional, patent-pending, Vector hood.)

C13a. Sweeping Hood Tension Spring Adjustment

Near the four corners of the sweeping hood are the sweeping hood tension springs. These springs help the sweeping hood to 'float' by relieving some of its weight from the sweeping surface. When the springs are adjusted correctly, you should be able to grasp the front corner of the sweeping hood with your hand and move it slightly with roughly 40 pounds of upward lift. This is the normal setting; however, some operator preference varies. Less tension shortens runner life. More tension creates a possibility that the hood may bounce on irregular surfaces, breaking the suction seal.



Fine Adjustment

1. Locate the eyebolt that connects the headspring to the frame.
2. Loosen or tighten the nut on the end of each eyebolt to raise or lower the head.

Coarse Adjustment

1. Raise the sweeping hood.
2. Unhook the chains from the springs or remove the 5/16" bolts that hold the spring chains to each side of the head.
3. Increase or decrease the number of chain links between the hood retainers and the ends of the hood springs, as needed.
4. If adjusting the hood spring tension does not correct the problem of excessive runner wear, the problem may be bent or uneven drag arms.



C13b. Worn Flaps

When new, the sweeping hood flaps will extend past the bottom of the drag shoes. As you use the sweeper more they will hang straight down and loose contact with the ground. When this happens, it is time to replace the flaps.



CAUTION! Do not attempt to adjust the drag shoes to extend the life of the flaps. The hood blast orifice must never be less than 1 ½ inches from the ground.

C13c. Replacing the Flaps

The sweeping hood is dependent upon forced air movement to provide maximum sweeping results. The flaps underneath the sweeping hood must maintain the air stream as it moves across the hood to the vacuum tube. The flaps may be allowed to wear until they hang straight down, and then should be replaced.

C13d. Sweeping Hood Removal

To remove the hood, remove the bolts holding the tension chains, hood cylinder chains and drag arms. Disconnect the water line. Then, loosen the hose clamps holding the 12-inch flex hoses to the hood. Lift the driver's side of the truck chassis with a floor jack and slide the hood out.

Turn the sweeping hood over. Place the hood on a work table or saw horses to make both the top and bottom sides accessible. Remove the knobs holding the front flap support channel. Remove the ¼" bolts and lock nuts that hold the front flap in place.

Discard the worn flap and install the new. The bolt heads should be on the air channel side of the hood, with the lock nuts on the top. Reinstall the support channel with the knobs. Slide the channel all the way to the front of the hood to allow the least amount of contact with the sweeping surface. Remove the ¼" bolts and lock nuts holding the center flap in place. Remove the worn flap and replace with the new.

Turn the hood back over, so the drag shoes are down. Remove the lock nuts that hold the rear cartridge in place. Remove the adjuster knobs and remove the worn cartridge. Make sure the bolts in the slide bars move freely. Thread the adjuster knobs onto the new cartridge and slide the adjuster bolts into the slots on the hood.

The slide bolt should insert into the holes in the cartridge. Loosely thread the lock nuts onto the slide bolts. Adjust the cartridge so the flap just touches the sweeping surface. Tighten the lock nuts. Tighten the adjuster knobs.

C13e. Reinstalling the Sweeping Hood

Raise the driver's side of the truck about three inches. Slide the sweeping hood under. Lower the truck. Reattach the drag arms, hood jump chain, and tension chains. (Reverse the removal instructions detailed in the previous section. Slide the 12-inch flex hose over the head tubes, and tighten the hose clamps.



C13f. Drag Shoe Adjustment and Replacement

The drag shoes on the sweeping hood have been designed for low maintenance and durability. The shoes are exposed to extreme punishment due to the job they perform. Therefore, we have inserted tungsten carbide inserts in the drag shoe to give them the longest life possible. You will need to replace the drag shoe when its shoe is worn through 80%.

Adjustment



CAUTION! Do not adjust the drag shoes so far up that the hood's blast orifice is less than 1 ½ inches from the ground.

Remember: Whenever drag shoe adjustment is necessary, the blast orifice must remain 1½-to-2 ¼ inches from the ground. Less than 1 ½ inches, the air stream becomes choked down. More than 2 ¼ inches and the blast velocity of the air striking the ground is lost. Never adjust the drag shoes so as to extend the life of the flaps. When the flaps no longer maintain a good seal, they should be replaced. Adjusting the drag shoes may affect the sweeping efficiency as a result of the change in blast orifice-to-ground distance.

To adjust:

1. Raise the sweeping hood and locate the drag shoes on either side.



2. Loosen the 5/8" nuts on each of the sweeping hood drag shoes.
3. Slide each drag shoe up or down its slots to achieve the required blast orifice to sweeping surface distance.
4. Retighten the 5/8 nuts on each of the sweeping hood drag shoes.
5. Lower the sweeping hood and make sure that the shoes are riding flat on the ground.

Replacement

To remove or replace the drag shoes, use the following instructions:

1. Locate the drag shoes. There is one shoe on each side of the sweeping hood. You will notice that bolts protrude through the drag shoes. The shoes are held in place against the hood by nuts and washers.
2. Raise the sweeping hood and remove the drag shoe's nuts and washers. Set the nuts and washers aside for reuse.
3. Pull the old shoe from the side of the sweeping hood and replace it with a new one.
4. Use the nuts and washers that you set aside and screw them down against the drag shoe. Do not tighten them until the new shoe is in the proper position. Once you have the shoe in the desired position then tighten all the nuts and washers.

Seasonal Changes

The sweeping hood's orientation to the ground may be manipulated by using some creative drag shoe adjustments designed to maximize performance in various seasonal conditions. By adjusting the leading ends of the drag shoes up more than their trailing ends, the pickup hood can be set to minimize frontal area. This is often preferable during heavy cleanup periods, such as spring cleanup season time. Adjustment in this way provides a faster channel of air/debris mixture and less distance that the debris must move. Just as making the frontal area shorter increases heavy sweeping performance, making the frontal area higher increases sweeping performance in lighter debris. This adjustment may be accomplished by performing the opposite of the above procedure, adjust the drag shoe's trailing ends up more than their leading ends. This is extremely helpful during the fall when leaves must be swept.

(Please note: These adjustments should only be made under extreme conditions. At all other times, the factory recommended adjustments will usually suffice. Prolonged usage with the above adjustments will require flap replacement when a re-adjustment to normal conditions is made.)

C14. Water system Maintenance

The standard water system consists of a gravity-feed water line, which connects to the sweeping hood and a Shur-Flo water pump for dust suppression for the hopper, gutter broom and optional front spray bar. The water line to the pickup head needs only an occasional check beneath the sweeping hood to be sure that its outlet has not become clogged. The water strainer should be cleaned daily and the water nozzles checked for correct operation and cleaned as needed.

When freezing temperatures are expected, either drain the water reservoir and remove filter cap or add antifreeze to the water as per the antifreeze manufacturer's instructions.

C14a. Water Pump

This sweeper is equipped with three Shur-Flo water pumps. Maintenance and troubleshooting procedures for the water pump are included in the Shur-Flo Pump Manual, which is included with the sweeper.



C14b. Water Filter Cleaning

The purpose of the water filter is to remove any particles from the water that might cause failure of the dust suppression systems spray nozzles. The plastic strainer is located beneath the left water reservoir, positioned in-line between the water reservoir and the water pump. The cap spins off easily for daily flushing. Approximately once a week the reservoir should be drained, the bottom of the strainer unscrewed, and the cylindrical screen within the strainer removed and cleaned. The frequency of this cleaning procedure will vary depending on the purity of the water from its fill source.

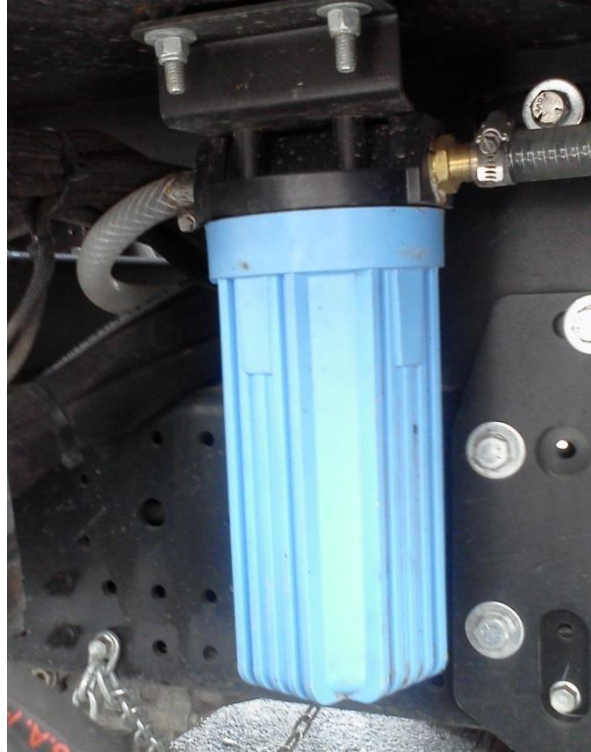

Cleaning

'Y' Strainer Disassembly

1. To drain, unscrew the bottom of the strainer. Remove and clean its screen.
2. Reassemble the strainer.

C14c. Water System Winterization

Whenever the dust suppression system is going to be used when the temperatures are expected to drop below freezing, environmentally-safe antifreeze should be added to the reservoir's water. Follow the antifreeze manufacturer's instructions for mixing. To drain the water from the reservoir, remove the strainer bowl under the water reservoir. Once the reservoir has emptied, reinstall the strainer bowl. Run the Flow-Jet pump to clean out any remaining water in the lines.

On the suction side of the water pumps there is a drain, this drain must be opened and remain open until needed.

VI. Troubleshooting

This section of the Manual has been designed to help identify and correct operational problems. We recommend you use the following guides as a starting point to solve any of the sweeping problems listed.

Each problem is listed with two columns under it. The first one is the 'Cause' column. These are the items most frequently found to occur when the problem listed is present. Across from the 'Cause' column is the 'Solution' column, which contains the steps you should take to correct the problem.

A. MISCELLANEOUS

1. UNUSUAL NOISE OR VIBRATION

CAUSE	SOLUTION
1. Fan out of balance.	1. Clean debris, rebalance or replace fan.
2. Fan shifted within housing.	2. Reposition fan.
3. Loose drive belt.	3. Tighten drive belt.
4. Loose bolts.	4. Tighten bolts.
5. Worn bearing(s).	5. Replace bearing(s).
6. Loose shaft-bearing bolts.	6. Tighten bolts.
7. Fan blades worn or broken.	7. Replace fan.
8. Engine	8. Locate, determine problem, and repair.

2. LOSS OF VACUUM POWER OR SWEEPER NOT PICKING UP

CAUSE	SOLUTION
1. Hopper not fully down/dump door open.	1. Lower hopper completely/lower dump door.
2. Sweeping too fast.	2. Slow down.



- | | |
|-------------------------------------------------|----------------------------------------------|
| 3. Sweeping hood not fully lowered. | 3. Lower hood completely. |
| 4. Sweeping engine throttle position too low. | 4. Throttle sweeper engine up. |
| 5. Blocked screen. | 5. Remove blockage. |
| 6. Blocked intake valve. | 6. Remove blockage. |
| 7. Faulty seal (fan, intake or doors). | 7. Replace seal(s). |
| 8. Door blocked open. | 8. Open door, clean surfaces, re-close door. |
| 9. Torn hose(s). | 9. Replace hose(s). |
| 10. Worn flaps. | 10. Adjust side plates or replace flaps. |
| 11. Bent or uneven drag arms. | 11. Straighten or replace drag arm. |
| 12. Bent pickup head. | 12. Replace pickup head. |
| 13. Improper hood spring tension. | 13. Adjust hood spring tension. |
| 14. Head baffle broken off. | 14. Replace baffle. |
| 15. Holes in hopper or fan housing. | 15. Repair holes. |
| 16. Loose drive belt. | 16. Tighten belt. |
| 17. Worn fan. | 17. Replace fan. |
| 18. Low auxiliary engine RPM. | 18. Seek service. |
| 19. Fan housing/exhaust door bleeder set wrong. | 19. Adjust bleeder. |

Suggested Spare Parts List

All mechanical devices have parts that wear out over time. Stewart-Amos Sweeper Co. has designed your sweeper keeping both the availability and cost of parts as key concerns. Many replacement parts can be found at your local hardware store while others will have to be obtained from Stewart-Amos Sweeper Co. The time involved in obtaining parts and replacing them is referred to as 'down time'.

Downtime is costly especially if your sweeper is inoperable for a number of days. To keep downtime at a minimum, we recommend that you maintain a small parts inventory at your location.

We suggest the following parts:

Part Description	Part Number	Suggested Quantity
Fan seal	9000	1
Intake seal	15109	1
Hopper intake tube	15205	1
Flap set	80011	1
Intake/pressure hose H/D	9135	1
Drive belt	9094	1
Drag Shoe	15405	2
Drag arm	15418	1
Inspection door seal	9072-68	1
Top door seal	9072-202	1
Dump door seal	9114-242	1
GB Brush Set	1143	2

Avoiding a single day's down time will make the initial investment justify the expense. Plan ahead so you can avoid down time and save on parts by eliminating 'next-day' shipping charges.

B. SWEEPING HOOD

1. HOOD NOT GLIDING PROPERLY – EXCESSIVE DRAG SHOE WEAR

CAUSE

1. Improper hood spring adjustment.
2. Bent hood channel.
3. Bent or uneven drag arms.
4. Improper side plate adjustment.

SOLUTION

1. Adjust hood spring tension.
2. Straighten or replace hood channel.
3. Straighten or replace drag arms.
4. Adjust side plates.

2. PICKUP HEAD DOWN

CAUSE

1. Leaking pickup head cylinder seal.
2. Check valve stuck open or not functioning.

SOLUTION

1. Rework seals or replace cylinder.
2. Replace or clean.

C. GUTTER BROOM

1. BROOM DISC SPINS TOO SLOWLY

CAUSE

1. Low outside temperature.
2. Sweeper engine throttle position.
3. Fluid viscosity is too high for operating temperature.
4. Broom hydraulic motor is bad.

SOLUTION

1. Run auxiliary engine longer before using broom to warm up hydraulic oil.
2. Throttle up as sweeper engine is too low.
3. Replace with lighter weight oil.
4. Rebuild or replace motor.

2. BROOM DISC SPINS TOO FAST

CAUSE

1. Hydraulic pressure/flow is too high.

SOLUTION

1. Adjust hydraulic pressure/flow.

3. DEBRIS TRAILS BETWEEN THE BROOM DISC AND THE SIDE OF THE PICKUP HEAD

CAUSE

1. Improper gutter broom head adjustment.

SOLUTION

1. Adjust the broom head tilt.

4. GUTTER BROOM STALLS IN HEAVY DEBRIS

CAUSE

1. Pressure to the broom motor is too low
2. Motor or pump seals leaking.

SOLUTION

1. Adjust pump pressure.
2. Seek service.

5. GUTTER BROOM FLINGS DEBRIS BACK INTO CURB

CAUSE

1. The broom disc is adjusted too flat.

SOLUTION

1. Adjust broom disc.

6. GUTTER BROOM FLINGS DEBRIS ACROSS THE STREET

CAUSE

1. The tilt angle of the broom head is too great.

SOLUTION

1. Adjust broom head.

7. BROOM SPINS BUT WILL NOT EXTEND/RETRACT

CAUSE	SOLUTION
1. Inside cylinder hydraulic hose or fitting is blocked.	1. Clear the blockage.
2. Directional valve malfunctioning.	2. Check the directional valve. Replace if needed.

8. BROOM OPERATES BUT WILL NOT LIFT

CAUSE	SOLUTION
1. Mechanical bind.	1. Check broom hardware for binds.
2. Switch or directional valve wire is loose or bad connection.	2. Check the wiring.
3. Leaking cylinder seals.	3. Replace the seals.
4. Blocked solenoid valve.	4. Replace the valve.

9. BROOM SPINS BUT WILL NOT LOWER

CAUSE	SOLUTION
1. Mechanical bind.	1. Check broom hardware for binds.
2. Bad solenoid valve cartridge.	2. Replace cartridge.
3. Solenoid valve electrical circuit incomplete.	3. Complete circuit.

10. BROOM RAISES BUT LEAKS DOWN IMMEDIATELY

CAUSE	SOLUTION
1. Solenoid valve stuck open.	1. Clean valve or replace.
2. Leaking cylinder seals.	2. Replace seals.

11. BROOM DROPS BUT WILL NOT OTHERWISE OPERATE

CAUSE	SOLUTION
1. Bad pump.	1. Service or replace pump.
2. Directional valve electrical circuit incomplete.	2. Complete circuit.
3. Directional valve ports blocked.	3. Seek service.

12. BROOM WILL NOT DROP OR OTHERWISE OPERATE

CAUSE	SOLUTION
1. Bad switch.	1. Replace switch.
2. Circuit breaker tripped.	3. Check circuit breaker and reset if necessary. Otherwise, search for any wiring problem.

D. HYDRAULIC SYSTEM

1. EXTREME HEAT, UNUSUAL NOISE, OR POOR PERFORMANCE FROM THE PUMP

CAUSE	SOLUTION
1. Reservoir cap is not vented.	1. Replace cap with vented equivalent.
2. Low oil level.	2. Check oil and fill as needed.
3. Dirty hydraulic oil.	3. Remove filters and clean or replace. Then change oil.
4. Bad pump.	4. Repair or replace pump.

2. HYDRAULIC SYSTEM WILL NOT OPERATE

CAUSE	SOLUTION
1. Mechanical pump is not being powered.	1. Engine must be operating. Determine reason why pump is not being driven and repair.
2. Hydraulic pump pressure low.	2. Adjust pump pressure.
3. Directional valve faulty or it has a poor ground.	3. Check electrical connections or replace valve.
4. No power to auxiliary pump.	4. Complete circuit.
5. Leaking cylinder seals.	5. Replace seals.
6. Major leak in hydraulic system.	6. Repair leak.
7. Internal leak in auxiliary pump.	7. Repair or replace pump.

E. WATER SYSTEM

1. NO WATER EXITING PUMP

CAUSE

1. Out of water.
2. Suction line clogged.
3. Air leak in line.

SOLUTION

1. Refill tank.
2. Clean suction strainer.
3. Tighten plumbing.

2. SPRAY NOZZLE NOT WORKING

CAUSE

1. Nozzle not on.
2. Clogged nozzle.
3. Crimped or clogged water line.
4. No power to pumps.

SOLUTION

1. Switch nozzle on.
2. Clean or replace nozzle.
3. Un-crimp or unclog line.
4. Determine loss of power; complete circuit.

3. LOW PRESSURE

CAUSE

1. Air leak in inlet plumbing.
2. Worn nozzle.
3. Worn pump.
4. Other.

SOLUTION

1. Disassemble, reseal, and reassemble.
2. Replace nozzle.
3. Replace Flow-Jet pump.
4. See water pump Owner's Manual.

NOTE:

STARFIRE R6 PARTS MANUAL

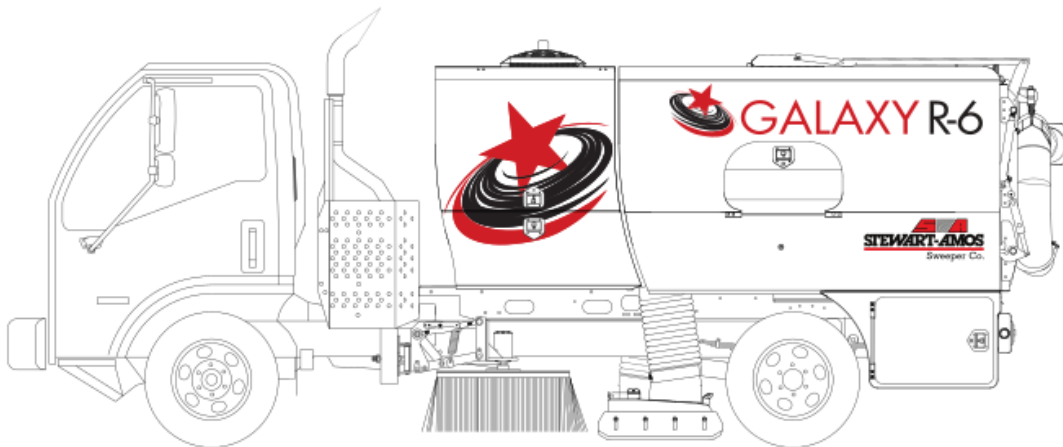

SN 3019 & up
Last updated Feb 2015



MAINFRAME ASSEMBLY

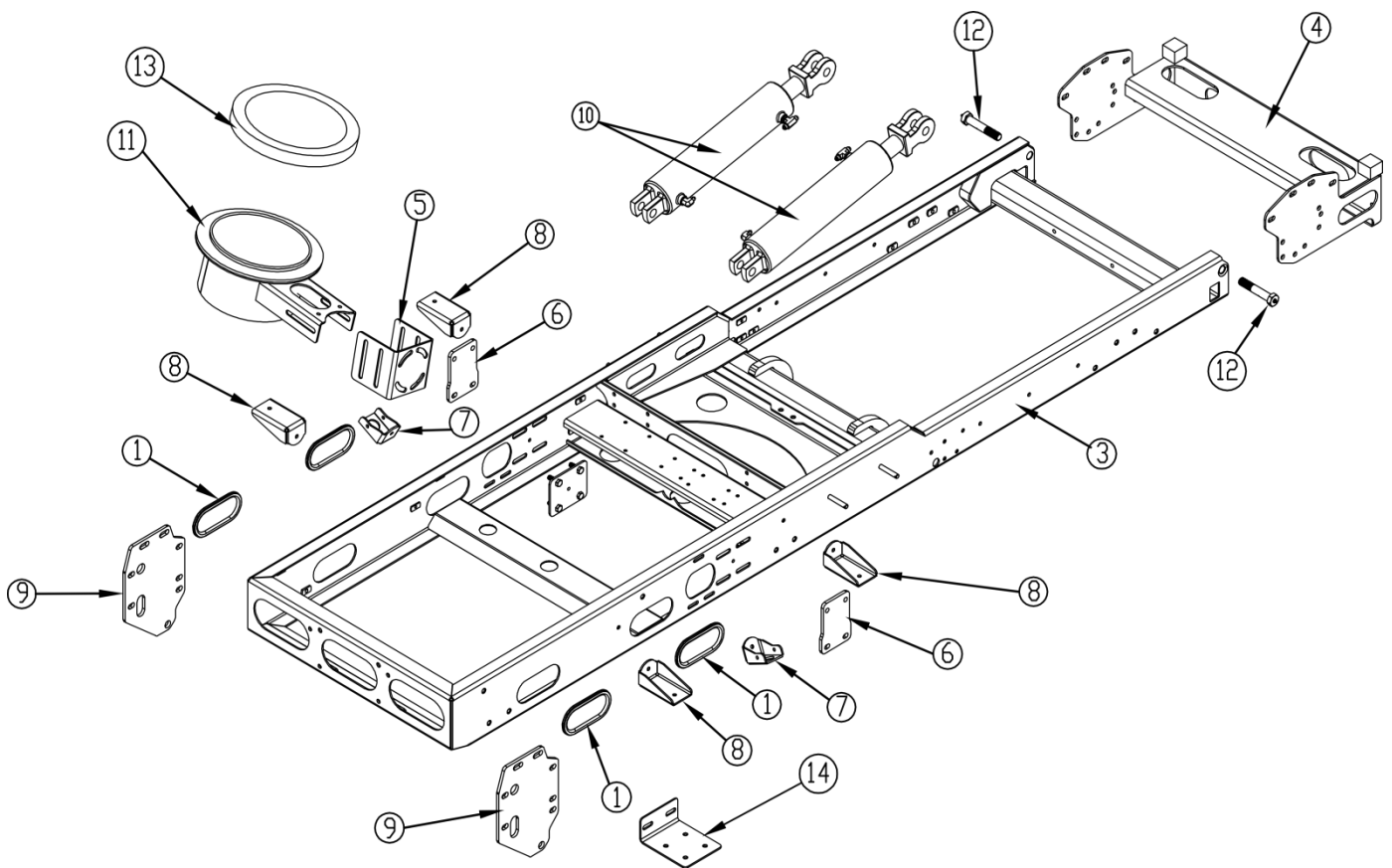

MAINFRAME ASSEMBLY

ITEM	PART #	DESCRIPTION	QTY
1	9066	RUBBER EDGE TRIM 17"	4
2	15100	BOLT PLATE TRANSITION	1
3	15101	MAIN FRAME WELDMENT	1
4	15102	BUMPER MOUNTING BRACKET	1
5	15103	TRANSITION MOUNTING BRACKET	1
6	15104	MIDDLE TIE DOWN MAIN FRAME	2
7	15105	HEAD SPRING HANGER	2
8	15106	HEAD SPRING HANGER	4
9	15107	DRAG ARM BRACKET	2
10	9122	DUMP CYLINDER	2
11	15108	INTAKE TRANSITION	1
12	15109	HINGE BOLT ASSEMBLY	2
13	9129	INTAKE TRANSITION SEAL	1
14	42430	FILTER MOUNT	1

POWER MODULE ASSEMBLY

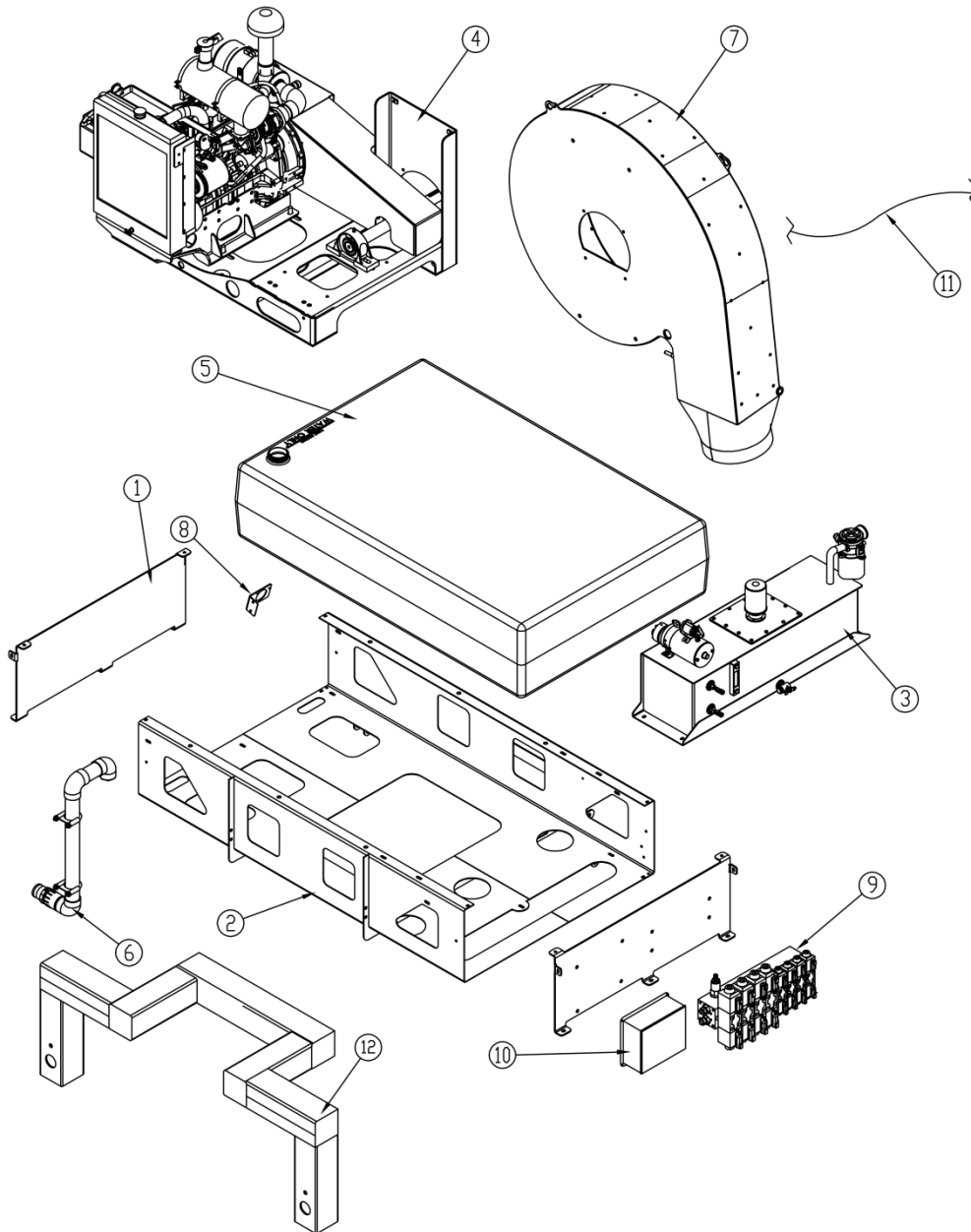

POWER MODUAL ASSEMBLY

ITEM	PART #	DESCRIPTION	QTY
1	15000	R-6 MOUNTING PLATE PM	2
2	15001	R-6 POWER MODULE WELDMENT	1
3	80183	HYDRAULIC RESERVOIR	1
4	80189	ENGINE SKID ASSEMBLY	1
5	15004	WATER RESERVOIR 200 GAL	1
6	15005	HYDRANT FILL TUBE WELDMENT	1
7	80187	FAN ASSEMBLY	1
8	15015	FUEL FILLER BRACKET	1
9	80210	HYDRAULIC VALVES	1
10	62512	AUX BOX	1
11	9169	BLEEDER DOOR CABLE	1
12	71201	GUTTER BROOM MOUNT	1

ENGINE SKID ASSEMBLY

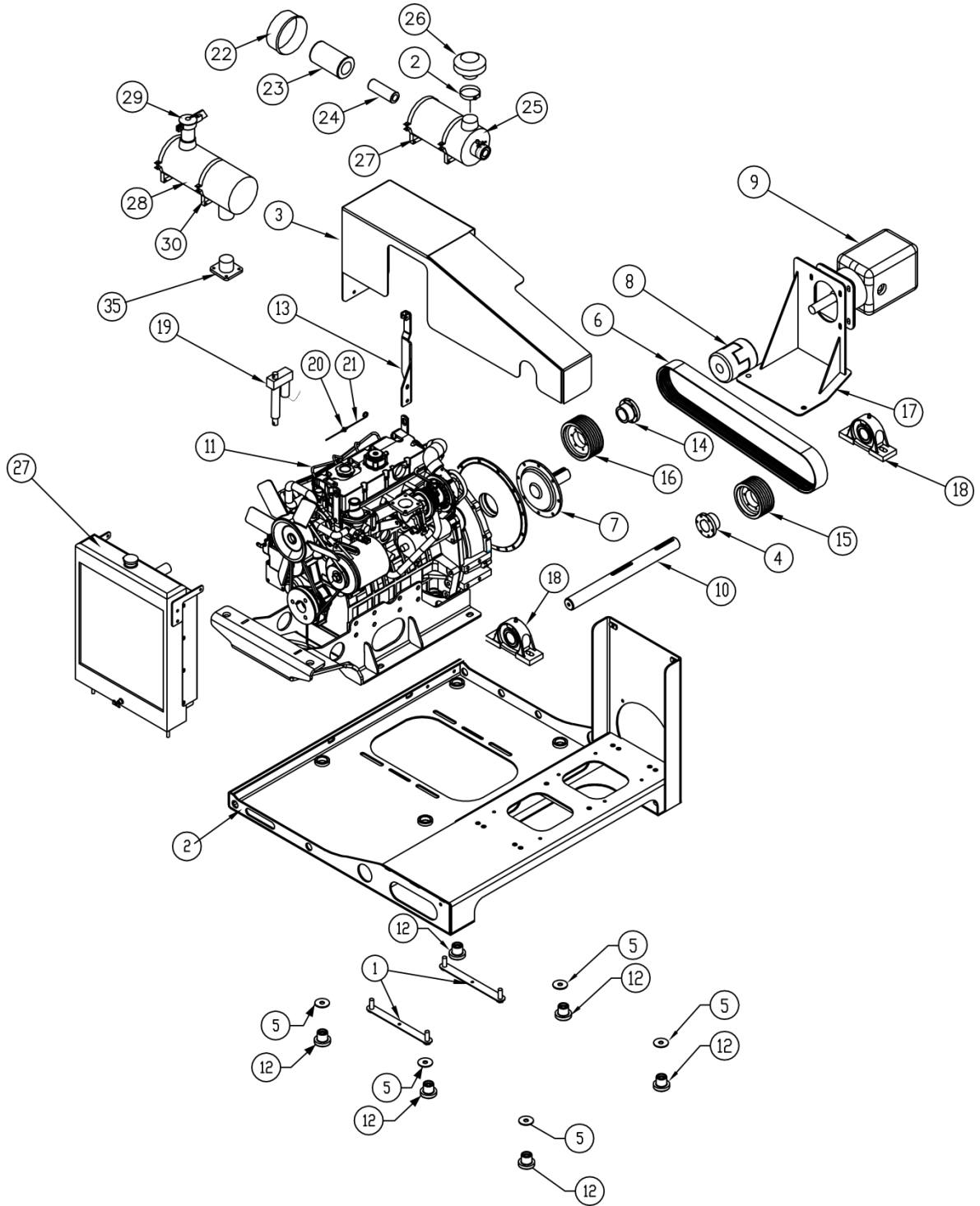

ENGINE SKID ASSEMBLY

ITEM	PART #	DESCRIPTION	QTY
1	15006	SLIDE BAR ENGINE SKID	2
2	15007	ENGINE SKID	1
3	15008	BELT GUARD	1
4	3034	BUSHING	1
5	15010	TAIL WASHER	6
6	9094	BELT	1
7	2072	DRIVE	1
8	2073	COUPLING	1
9	2074	HYDRAULIC PUMP	1
10	15022	FAN SHAFT	1
11	2071	ENGINE	1
12	9096	VIBRATION ISOLATOR	6
13	15021	THROTTLE ARM	1
14	9031	BUSHING	1
15	9086	PULLEY	1
16	9087	PULLEY	1
17	15801	PUMP MOUNT	1
18	9017	BEARING	2
19	1387	THROTTLE ACTUATOR	1
20	1299	THROTTLE GUIDE	1
21	1388	THROTTLE ACTUATOR CABLE	1
22	2264	COVER	1
23	2267	FILTER PRIMARY	1
24	2268	FILTER SECONDARY	1
25	2262	AIR CLEANER	1
26	2271	INLET HOOD	1
27	2272	MOUNTING BAND	1
28	2276	MUFFLER	1
29	2277	STACK CAP	1
30	2278	MUFFLER MOUNTING BAND	1
31	2257	ALTERNATOR (NOT SHOWN)	1
32	2258	STARTER (NOT SHOWN)	1
33	2259	FUEL FILTER (NOT SHOWN)	1
34	2260	SOLENOID (NOT SHOWN)	1
35	2254	MUFFLER FLANGE	1

HYDRANT FILL TUBE ASSEMBLY

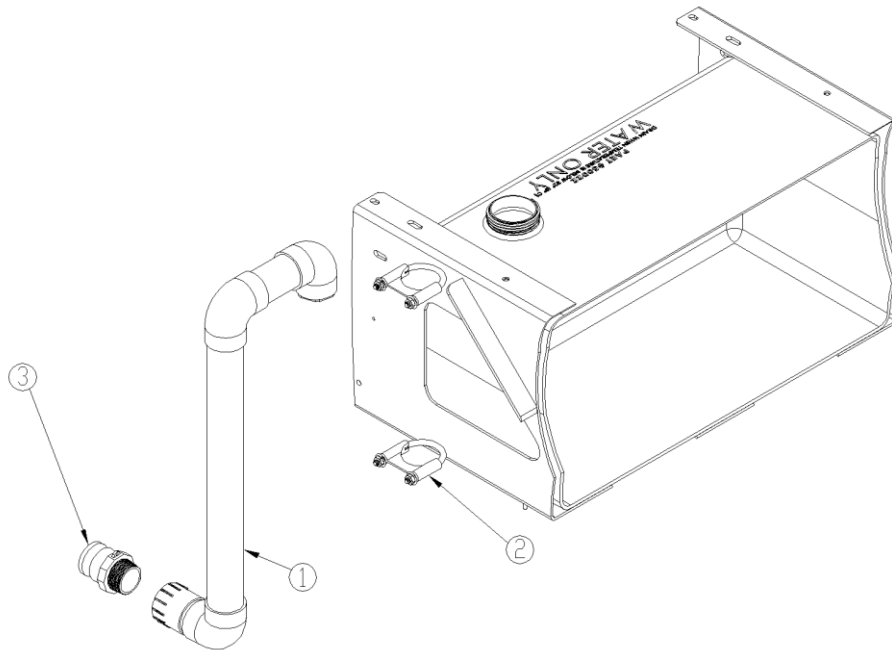

ITEM	PART #	DESCRIPTION	QTY
1	15005	HYDRANT FILL TUBE	1
2	9084	CLAMPING U-BOLT	2
3	9105	QUICK DISCONNECT	1
4	9102	FIRE HOSE (NOT SHOWN)	1
5	9103	KING NIPPLE (NOT SHOWN)	1
6	9076	HOSE CLAMP (NOT SHOWN)	1
7	9104	BRASS HYDRANT COUPLING (NOT SHOWN)	1
8	9106	QUICK DISCONNECT (NOT SHOWN)	1
9	9107	ALUMINUM DUST CAP (NOT SHOWN)	1

80210 MANIFOLD R6 STD

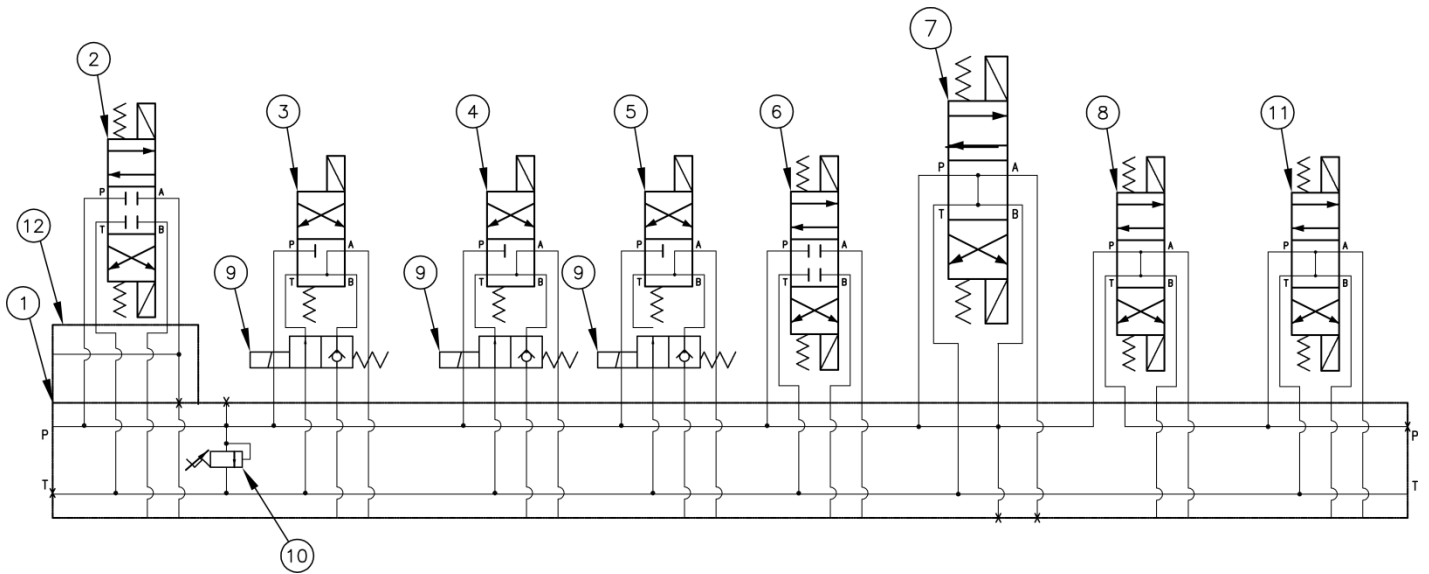

ITEM	PART #	DESCRIPTION	QTY
1	2006	MANIFOLD	1
2	2001	HOPPER LIFT CYLINDER VALVE	1
3	1989	LH GUTTER BROOM LIFT CYLINDER VALVE	1
4	1989	RH GUTTER BROOM LIFT CYLINDER VALVE	1
5	1989	PICKUP HEAD LIFT	1
6	2001	PICKUP HEAD TILT	1
7	2005	DUMP VALVE	1
8	2005	LH GB MOTOR	1
9	1990	FLOAT VALVE	3
10	2000	RELIEF VALVE	1
11	2005	RH GB MOTOR	1
12	1992	TAPPING PLATE	1

HOSES SCHEMATIC

HOSE SCHEMATIC

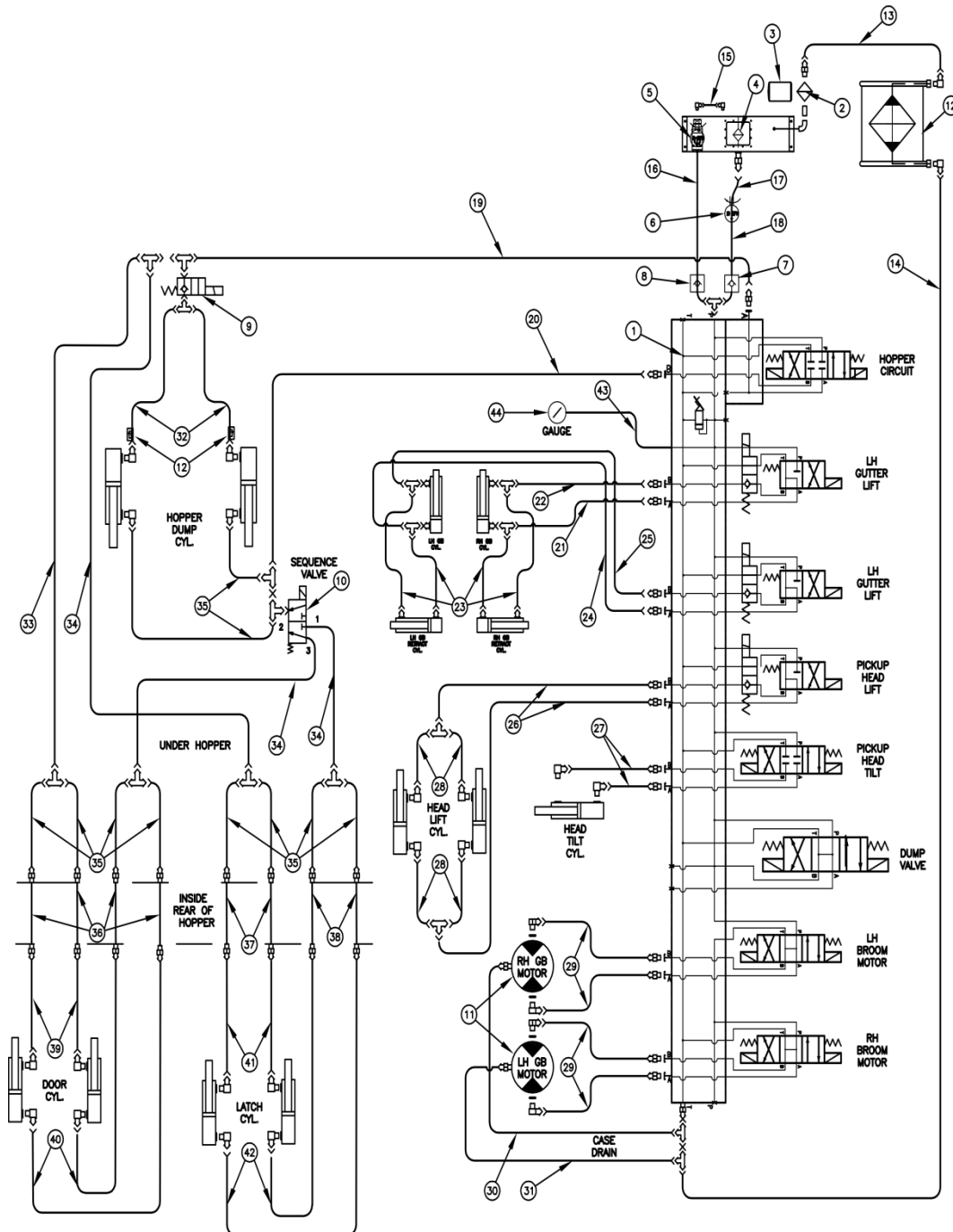

HOSES SCHEMATIC

ITEM	PART #	DESCRIPTION	QTY
1	2006	MANIFOLD	1
2	1411	HYD. FILTER BASE	1
3	1416	HYD. FILTER	1
4	9020	SUCTION SCREEN	1
5	3203	AUXILIARY HYD. PUMP	1
6	2074	HYD. PUMP	1
7	2219	INLINE CHECK VALVE	1
8	2221	INLINE CHECK VALVE	1
9	1068	FLOAT VALVE	1
10	2222	SEQUENCE VALVE	1
11	3243	GB MOTOR	2
12	1955	HYD. OIL COOLER	1
13	9329	HOSE (COOLER TO TANK)	1
14	9328	HOSE (MANIFOLD TO COOLER)	1
15	9330	HOSE (TANK TO AUX HYD PUMP)	1
16	9331	HOSE (AUX HYD PUMP TO MANIFOLD)	1
17	9326	HOSE (TANK TO PUMP)	1
18	9327	HOSE (PUMP TO MANIFOLD)	1
19	9313	HOSE (MANIFOLD TO DUMP VALVE	1
20	9314	HOSE (MANIFOLD TO SEQUENCE VALVE	1
21	9320	HOSE (MANIFOLD TO RH GB CYL)	3
22	9319	HOSE (MANIFOLD TO RH GB CYL)	1
23	1428	HOSE (GB CYL TO RETRACT CYL)	4
24	9323	HOSE (MANIFOLD TO LH GB CYL)	1
25	9322	HOSE (MANIFOLD TO LH GB CYL)	1
26	9315	HOSE (MANIFOLD TO PICKUP HEAD)	2
27	9316	HOSE (PICKUP HEAD TEE TO CYL)	4
28	9317	HOSE (MANIFOLD TO PICKUP HEAD TILT CYL)	1
29	9318	HOSE (MANIFOLD TO GB MOTORS)	1
30	9339	HOSE (RH CASE DRAIN TO MANIFOLD)	2
31	9340	HOSE (LH CASE DRAIN TO MANIFOLD)	1
32	9312	HOSE (DUMP VALVE TO DUMP CYL)	2
33	9301	HOSE (DUMP VALVE TO DUMP CYL)	1
34	9300	HOSE (DUMP VALVE TO DUMP CYL)	3
35	9302	HOSE (TEE TO FLOOR BULKHEADS)	8
36	9303	HOSE (HOPPER INSIDE CORNER)	4
37	9304	HOSE (HOPPER INSIDE CORNER)	2
38	9305	HOSE (HOPPER INSIDE CORNER)	2
39	9308	HOSE (OUTSIDE DOOR CYL)	2
40	9309	HOSE (OUTSIDE DOOR CYL)	2
41	9306	HOSE (OUTSIDE LATCH CYL)	2
42	9307	HOSE (OUTSIDE LATCH CYL)	2
43	9332	HOSE (PSI GUAGE)	1
44	2082	PSI GUAGE	1

HYDRAULIC RESERVOIR ASSEMBLY

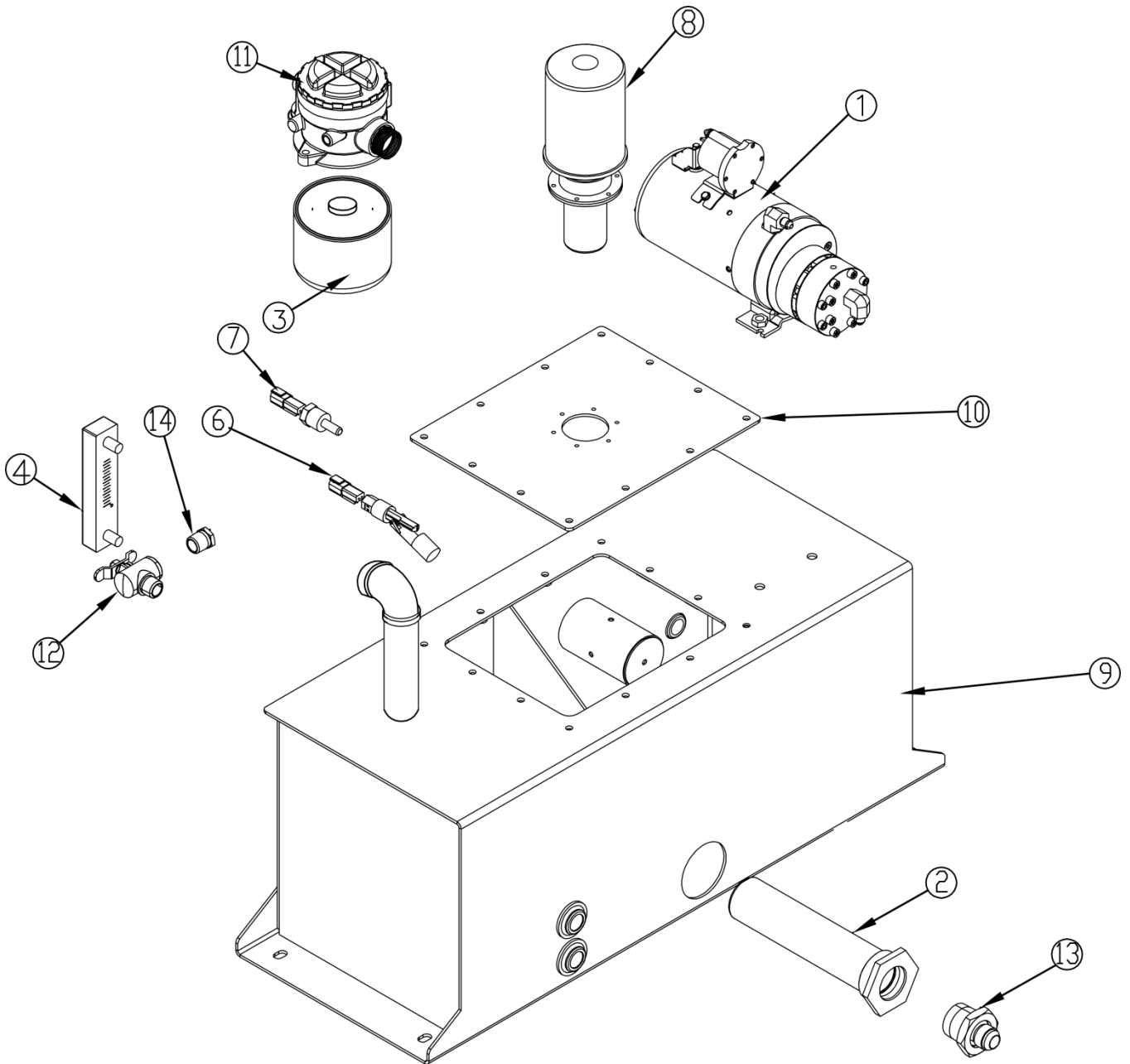

HYDRAULIC RESERVOIR ASSEMBLY

ITEM	PART #	DESCRIPTION	QTY
1	3203	AUX HYD PUMP	1
2	9020	SUCTION STRAINER	1
3	1416	FILTER	1
4	1062	SIGHT GAUGE	1
6	9074	FLUID LEVEL SENSOR	1
7	9075	TEMPERATURE SWITCH	1
8	9098	HYDRAULIC TANK BREATHER	1
9	15002	HYD RESERVOIR	1
10	15003	INSPECTION COVER	1
11	1411	HYD. FILTER BASE	1
12	9030	VALVE	1
13	9041	BRASS PLUG	1
14	9080	CONNECTOR	1

FAN HOUSING ASSEMBLY

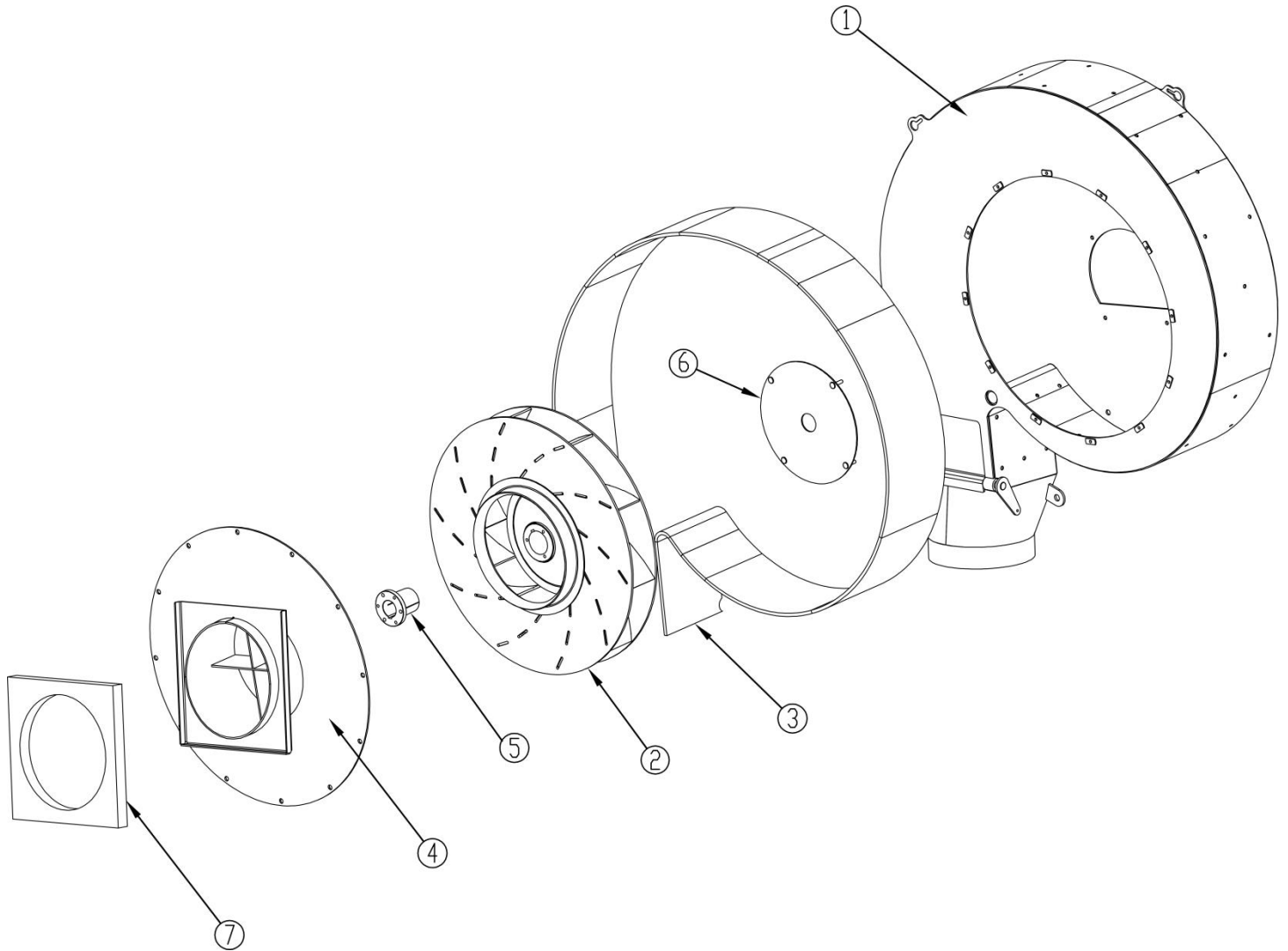

ITEM	PART #	DESCRIPTION	QTY
1	15012	R4 FAN HOUSING	1
2	15014	30" FAN S-SERIES	1
3	80190	LINER KIT FAN HOUSING	1
4	15013	BACKPLATE WELDMENT	1
5	9034	BUSHING	1
6	9074	FAN SEAL	1

FAN LINER KIT ASSEMBLY

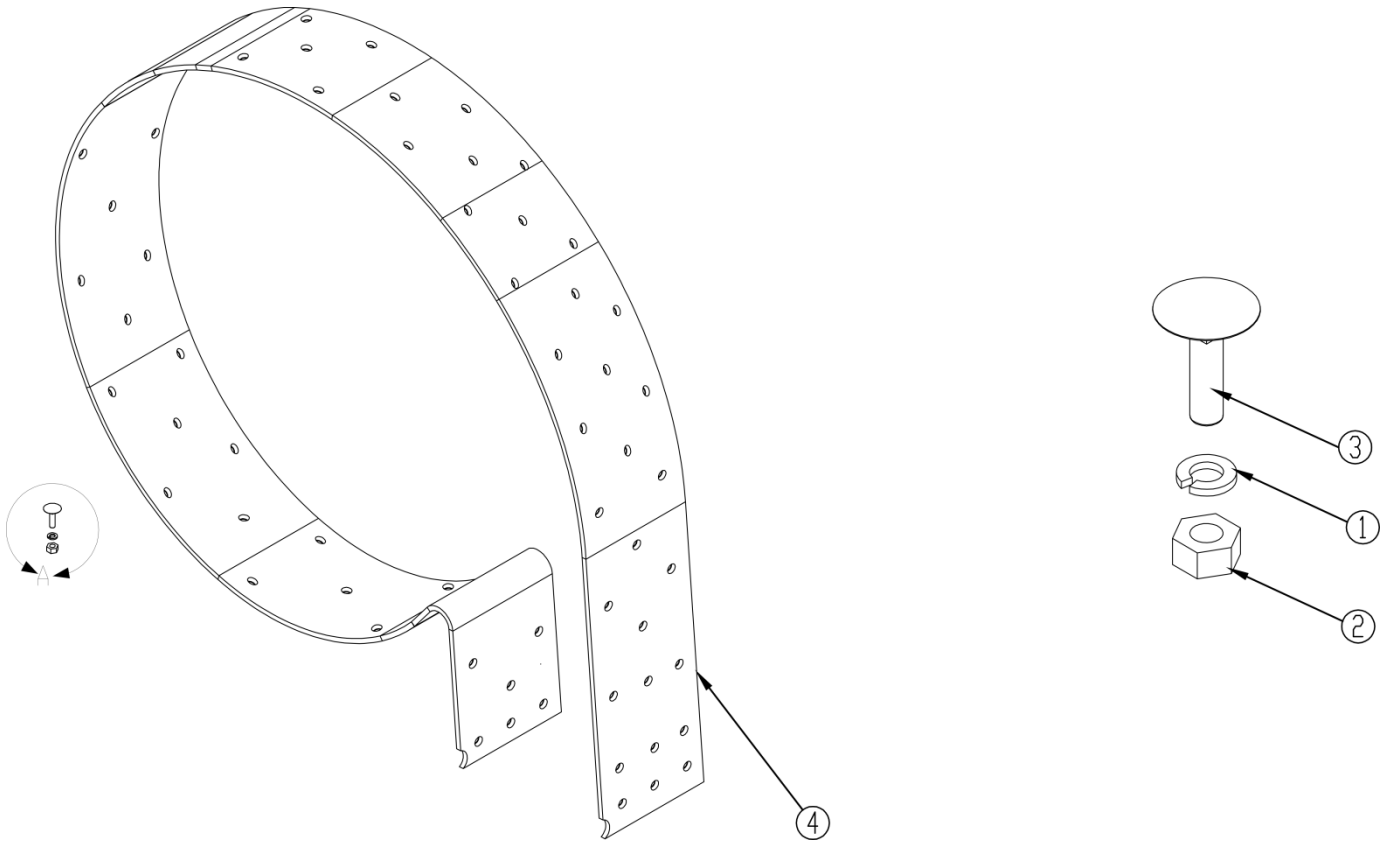

ITEM	PART #	DESCRIPTION	QTY
1	9004	WASH SPRING LOCK	40
2	9005	HEX NUT	40
3	9007	ELEVATOR BOLT	40
4	15019	RUBBER LINER	1

COMPLETE HOPPER ASSEMBLY

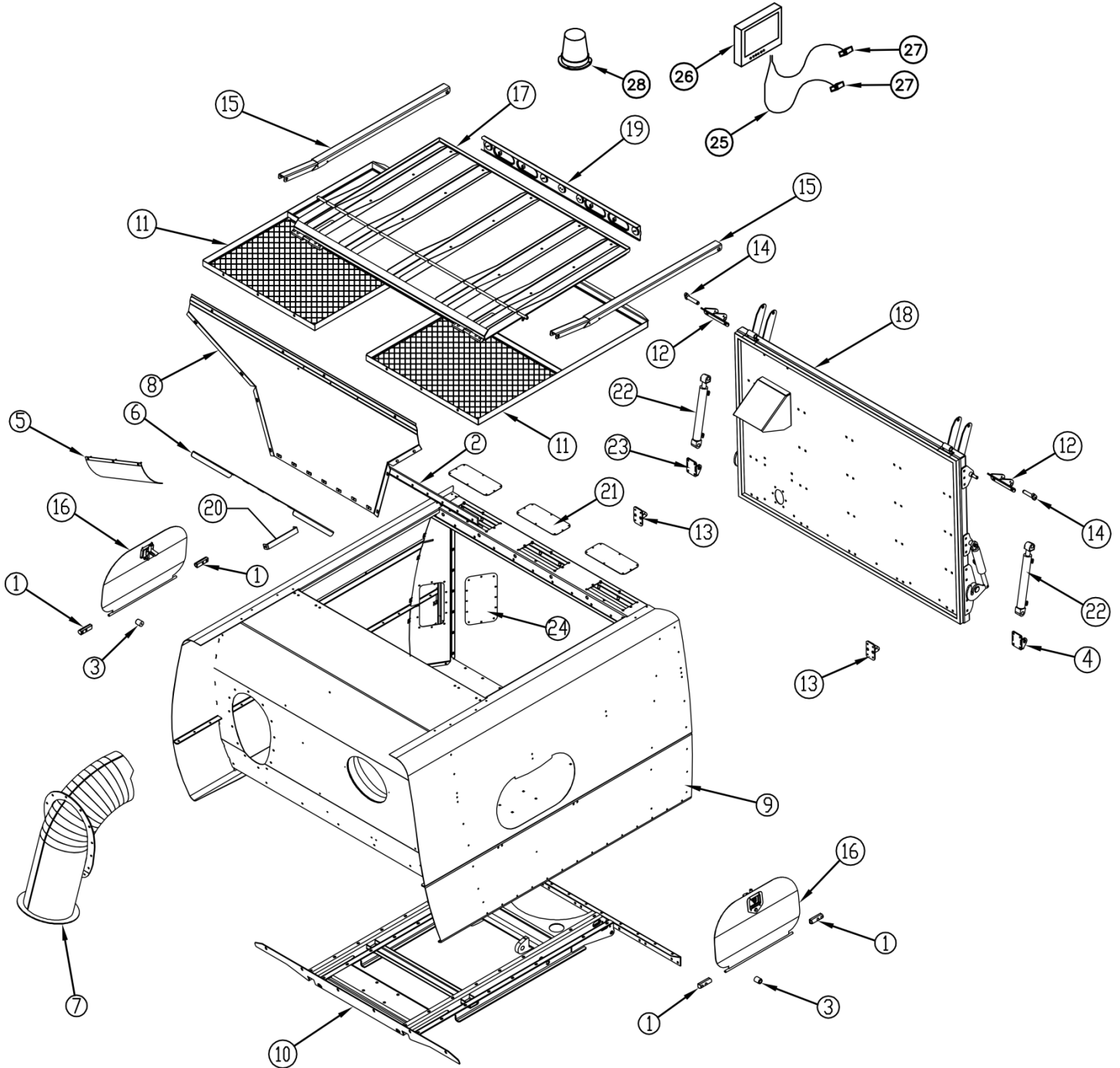

COMPLETE HOPPER ASSEMBLY

ITEM	PART #	DESCRIPTION	QTY
1	15200	HINGE, ALUMINUM BLACK	8
2	15201	RUBBER HINGE SEPARATOR DOOR	1
3	9067	RUBBER BUMPER	2
4	15265	LH DUMP DOOR CYL MOUNT	2
5	15203	AIR VANE SEPARATOR	1
6	15204	SEPARATOR DOOR HOPPER	1
7	15205	HOPPER INTAKE TUBE	1
8	15206	REAR SEPARATOR COVER	1
9	80193	HOPPER ASSEMBLY	1
10	15220	HOPPER FRAME WELDMENT	1
11	15221	SCREEN FRAME WELDMENT	2
12	15222	DUMP DOOR HINGE BRACKET	2
13	15223	STRIKER LATCH REAR DOOR	2
14	15224	HINGE PIN	2
15	15225	CONNECTOR ARM	2
16	80194	HOPPER INSPECTION DOOR	2
17	80195	HOPPER TOP DOOR	1
18	80196	DUMP DOOR	1
19	80197	REAR LIGHT BAR	1
20	15243	FRONT HOPPER SEPARATOR BRACE	1
21	15244	ACCESS COVER PLATE HOPPER	3
22	15245	DUMP DOOR CYLINDER	2
23	15260	RH DUMP DOOR CYL MOUNT	1
24	15258	ACCESS COVER	2
25	1968	CAMERA CABLE	2
26	1969	CAMERA/MONITOR	1
27	1970	CAMERA	2
28	1916	BEACON	1
29	15817	LIMB GUARD (OPTIONAL)	1

HOPPER ASSEMBLY

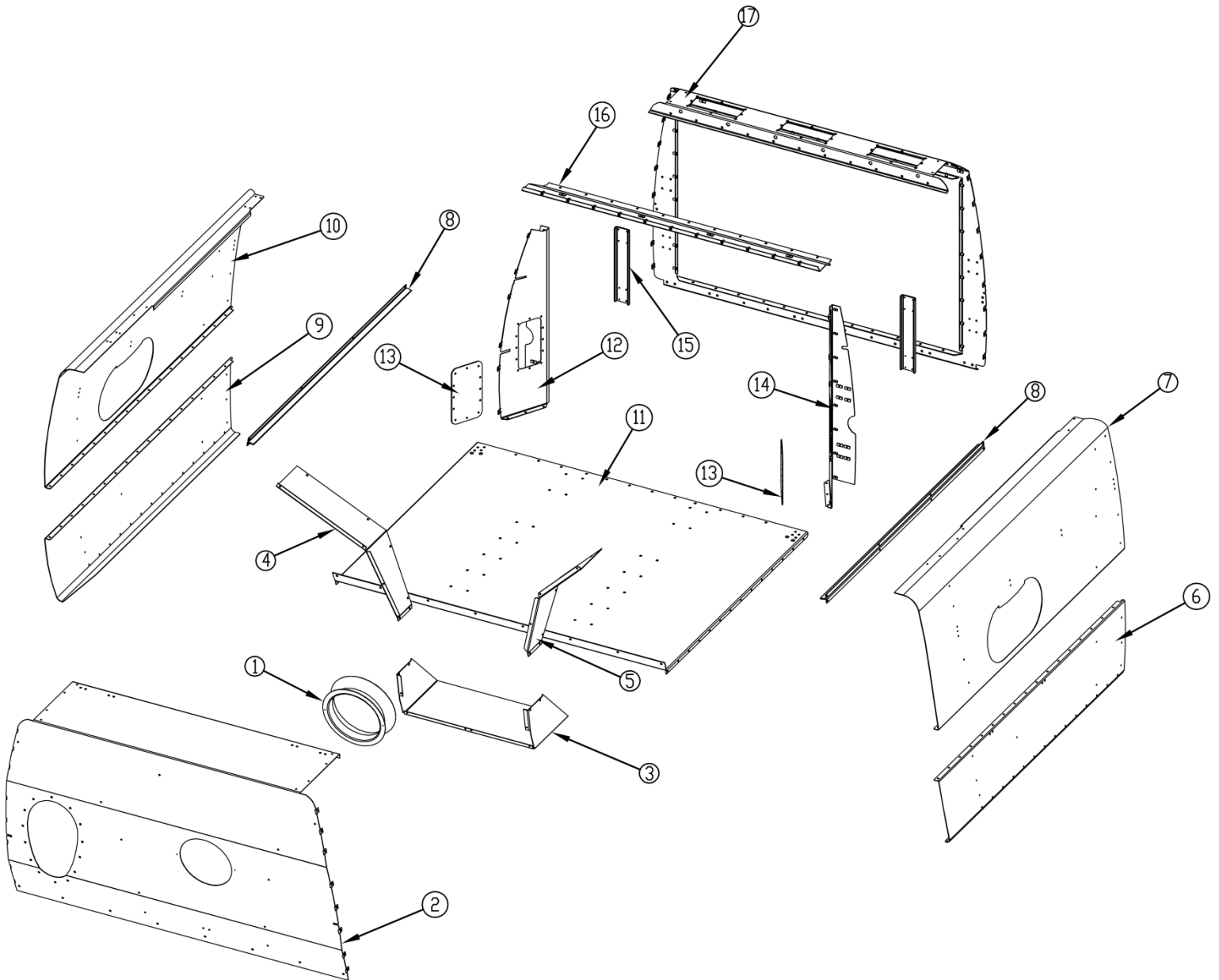

HOPPER ASSEMBLY

ITEM	PART #	DESCRIPTION	QTY
1	15248	SCROLL HOPPER SEPARATOR	1
2	15215	FRONT HOPPER	1
3	15207	LOWER BASIN SEPARATOR	1
4	15208	RH SEPARATOR WRAP	1
5	15209	LH SEPARATOR WRAP	1
6	15213	LH LOWER HOPPER SIDE	1
7	15211	LH UPPER HOPPER SIDE	1
8	15210	UPPER SIDE BRACE	2
9	15214	RH LOWER HOPPER SIDE	1
10	15212	RH UPPER HOPPER SIDE	1
11	15216	HOPPER FLOOR	1
12	15218	RH DUMP GUSSET	1
13	15258	ACCESS COVER DUMP GUSSET	2
14	15217	LH DUMP GUSSET	1
15	15219	BOLT PLATE REAR HOPPER	1
16	15249	UPPER SEAL REAR BULKHEAD	1
17	15247	REAR HOPPER	1

TOP DOOR ASSEMBLY

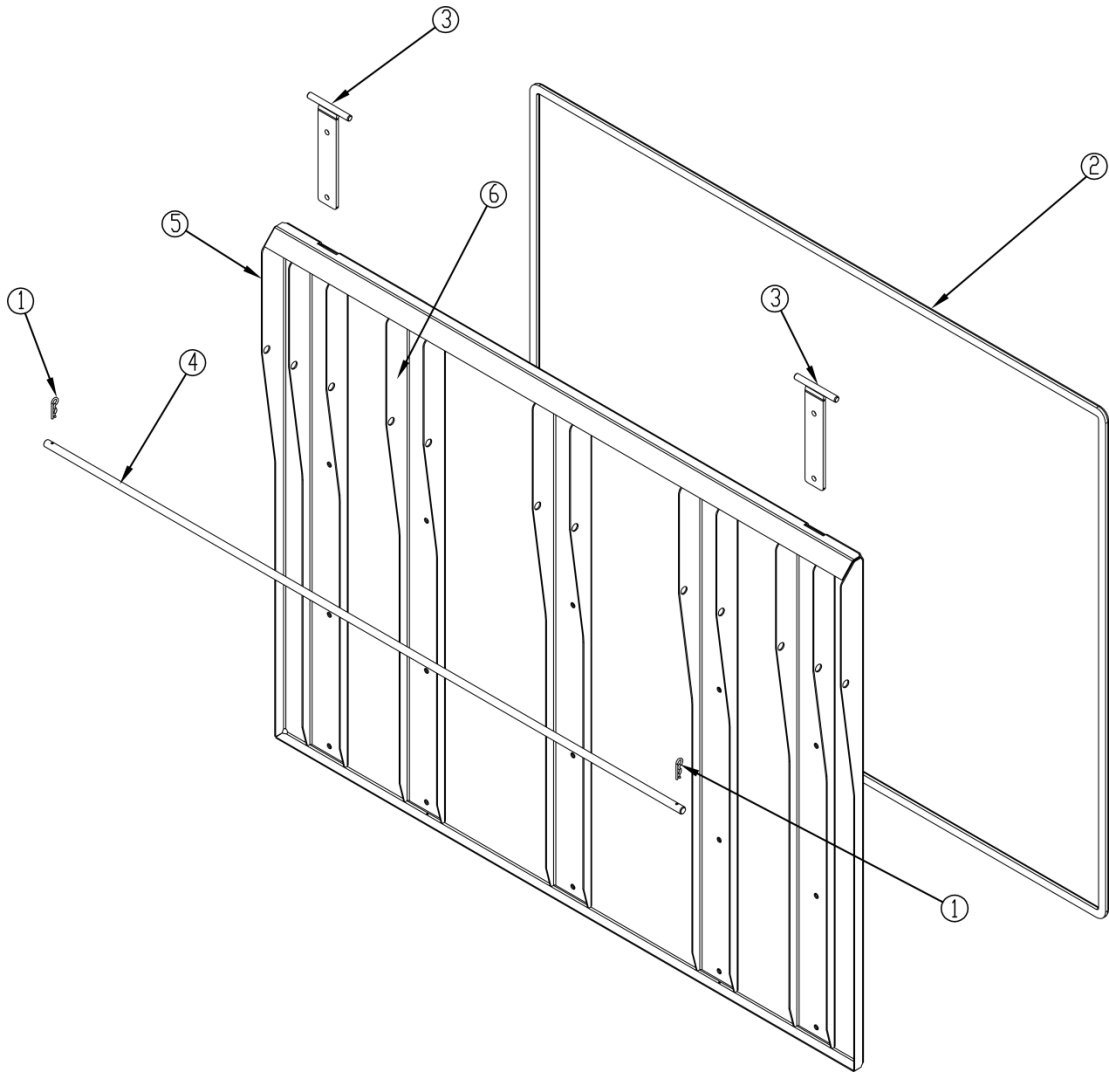

ITEM	PART #	DESCRIPTION	QTY
1	9037	HAIR PIN COTTER	2
2	9072-202	SEAL	1
3	15227	HINGE	2
4	15255	LIFTING ROD	1
5	15250	TOP DOOR SKIIN	1
6	15251	TOP DOOR BRACE	5

INSPECTION DOOR ASSEMBLY

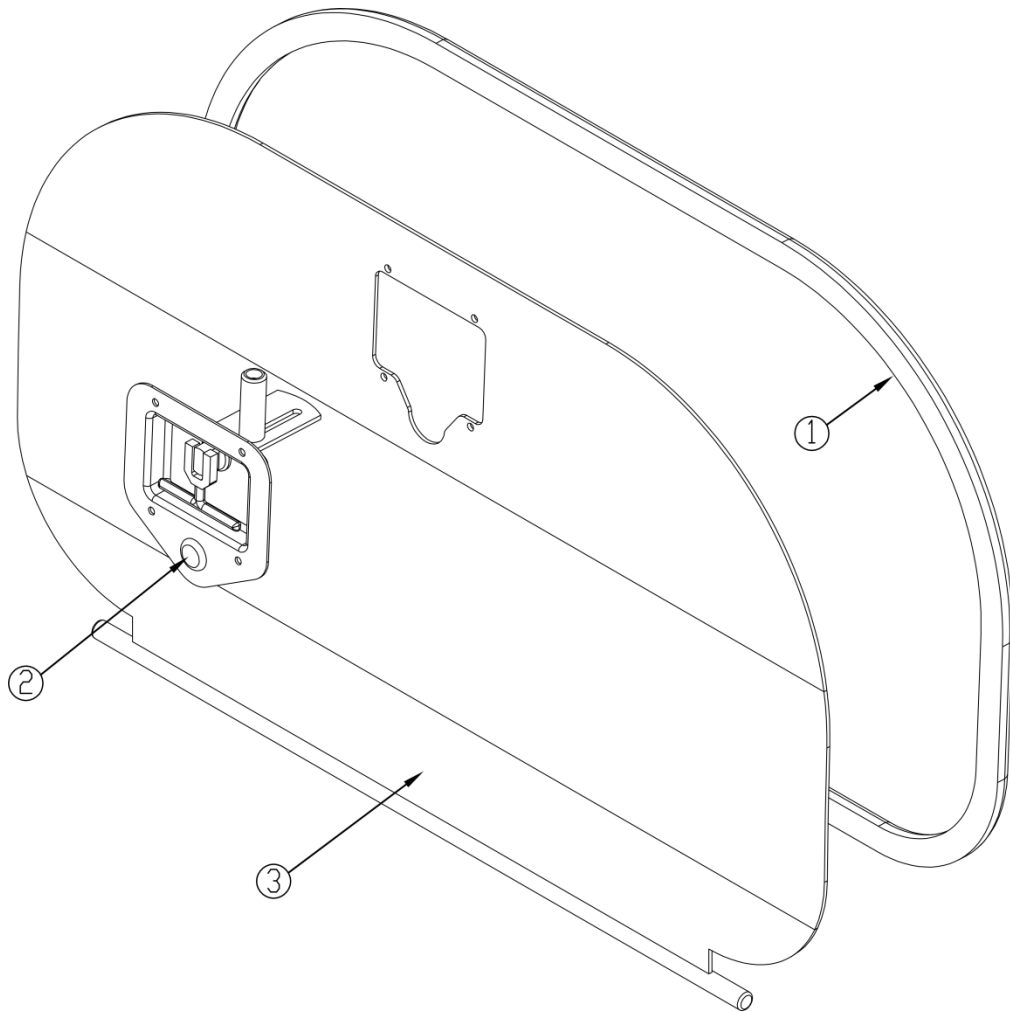

ITEM	PART #	DESCRIPTION	QTY
1	9072-68	SEAL	1
2	9081	SS SHROUD LATCH	1
3	15226	HOPPER INSPECTION DOOR	1

DUMP DOOR ASSEMBLY

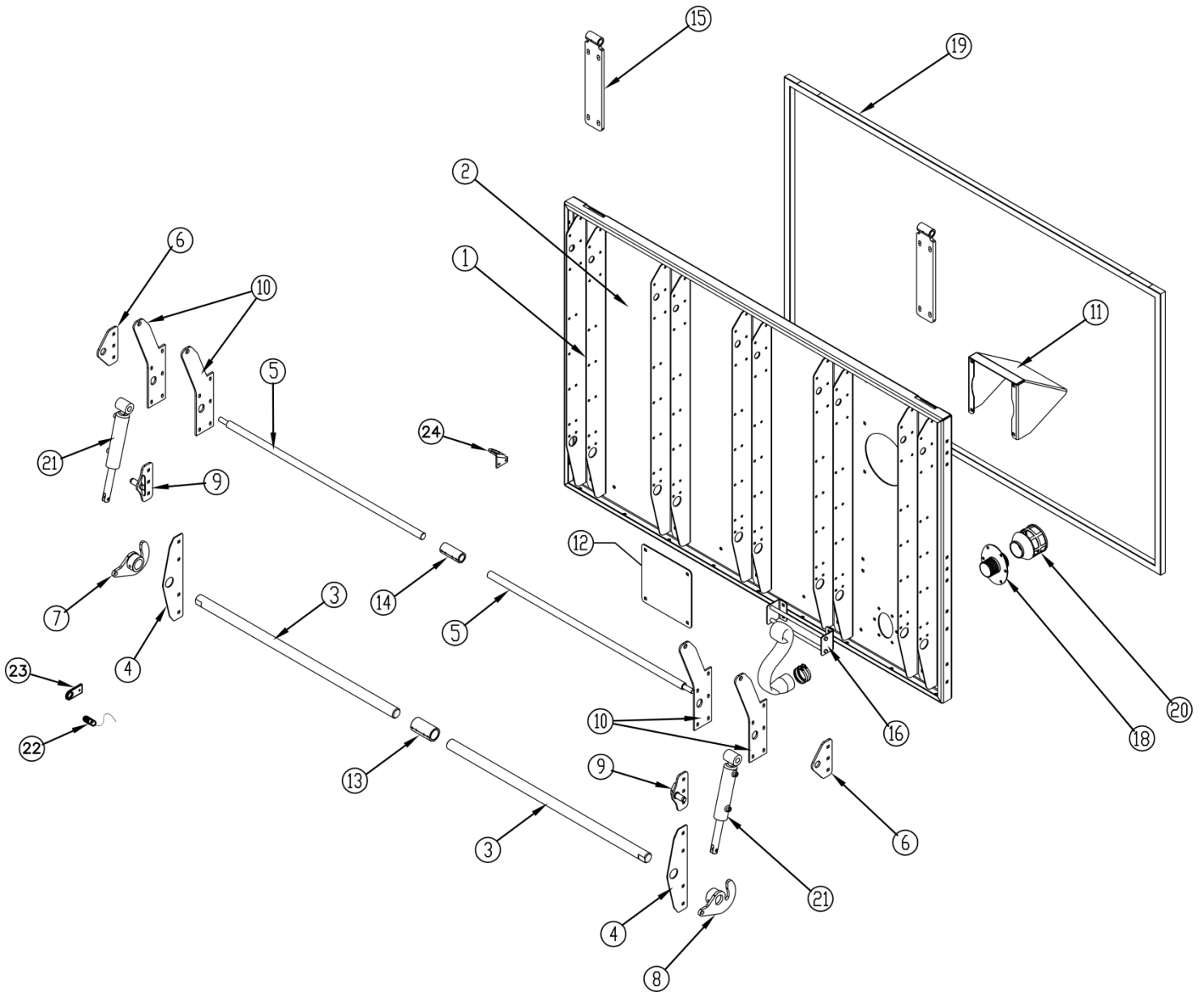

DUMP DOOR ASSEMBLY

ITEM	PART #	DESCRIPTION	QTY
1	15253	INNER VERTICAL BRACE	5
2	15252	HOPPER DUMP DOOR PANEL	1
3	15234	LATCH ROD	2
4	15235	RETAINER PLATE LATCH ROD	2
5	15236	CYLINDER PIN ROD	2
6	15237	SUPPORT PLATE	2
7	15229	LH LATCH CAM	1
8	15230	RH CAM LATCH	1
9	15231	LATCH CYLINDER MOUNTING BRACKET	2
10	15233	CONNECTING BAR HINGE PLATE	4
11	15710	HAND HOSE DEFLECTOR	1
12	15238	COVER PLATE (W/O HAND HOSE)	1
13	15240	LATCH ROD COUPLING	1
14	15241	DOOR CYLINDER ROD COUPLING	1
15	15228	DUMP DOOR HINGE	2
16	15256	HOSE RACK	1
17	15805	PROX MOUNT LATCH	1
18	15257	DRAIN HOLE COVER	1
19	9114-242	RECTANGLE SEAL	1
20	1393	2" STRANER	1
21	9110	HYD CYL 1-1\2 X 4	1
22	1087-3	PROXIMITY SWITCH	2
23	15804	DOOR PROXIMITY MOUNT	1
24	15805	LATCH PROXIMITY MOUNT	1

LIGHT BAR ASSEMBLY

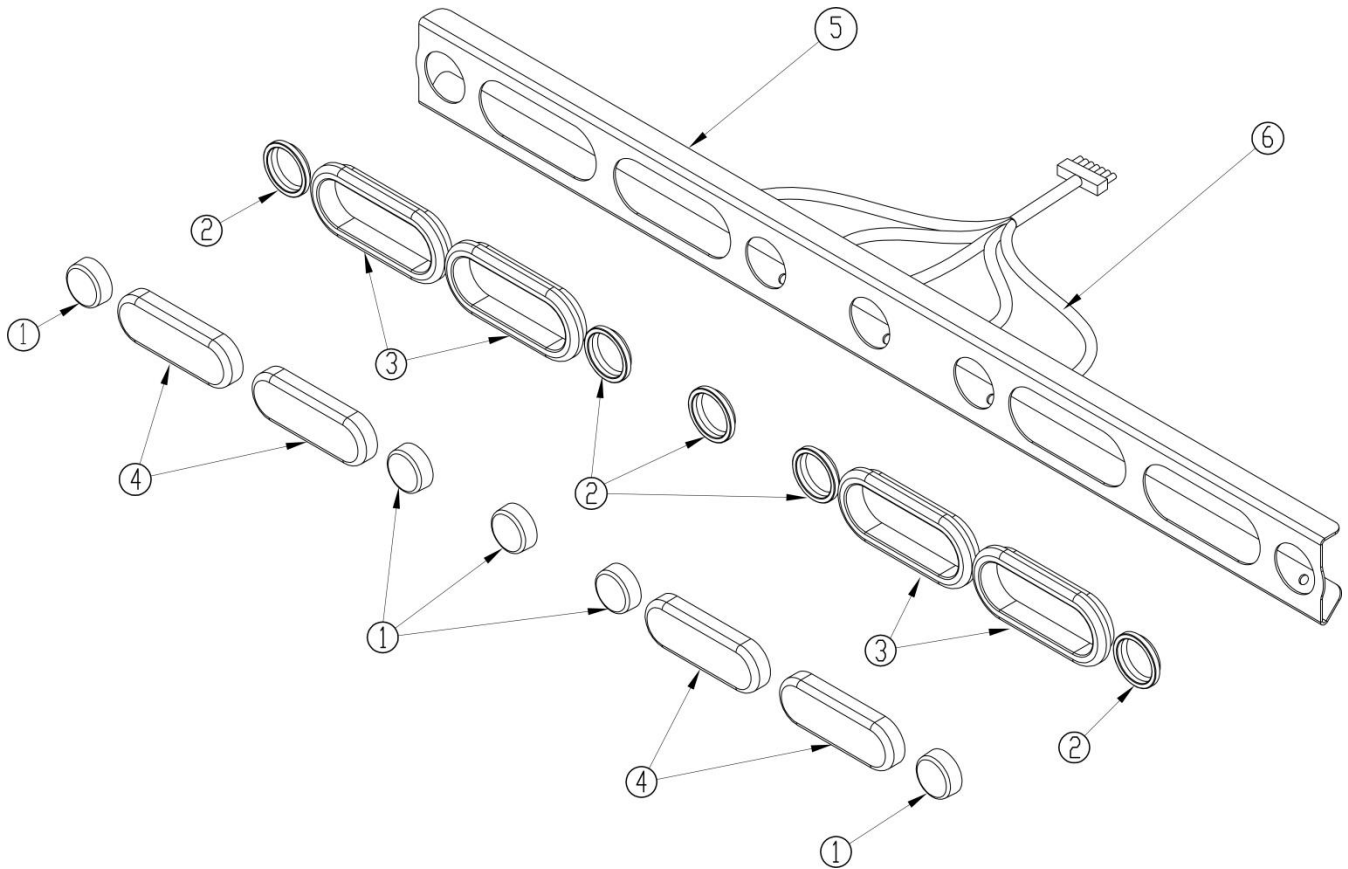

ITEM	PART #	DESCRIPTION	QTY
1	1028	CLEARANCE LIGHT (LED)	5
2	1131	GROMMET	5
3	9052	OVAL LIGHT GROMMET	4
4	9115	OVAL AMBER STROBE LIGHT	4
5	15242	LIGHT BAR REAR HOPPER	1
6	12518	TOP MARKER HARNESS	1

80211 PICKUP FLAPS ASSY

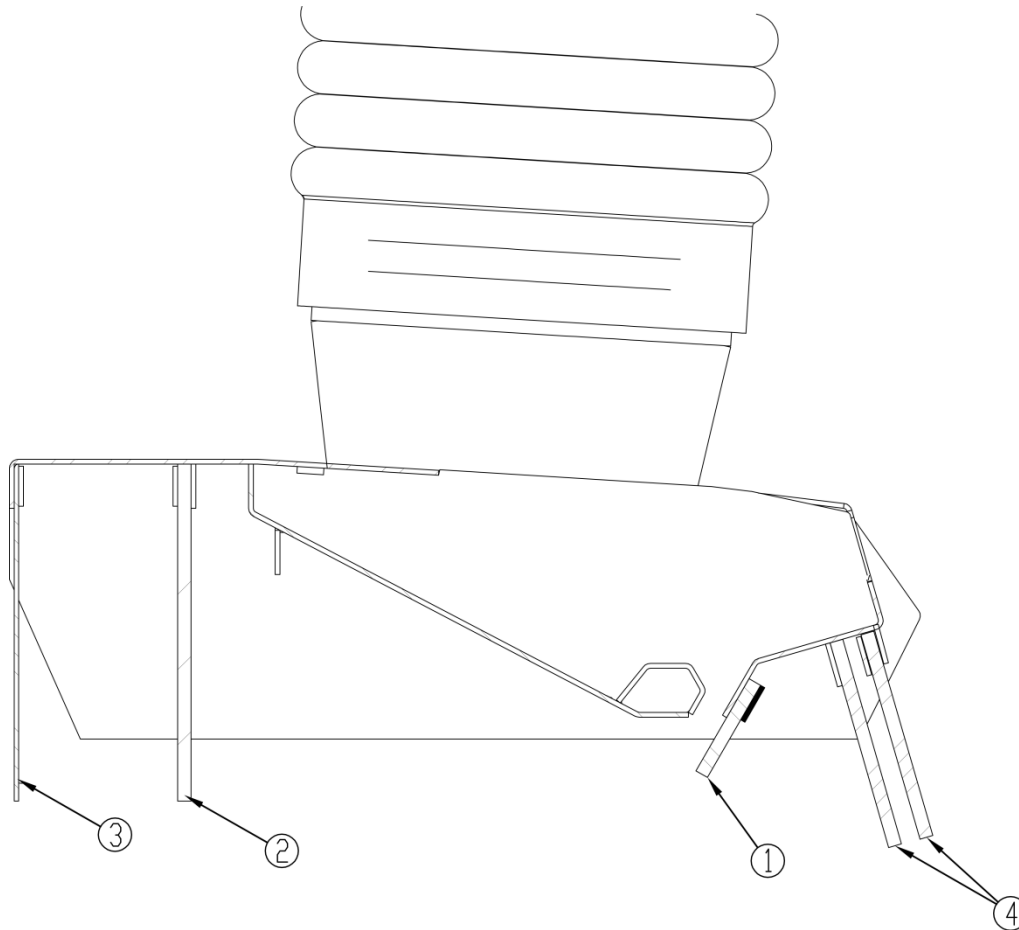

ITEM	PART #	DESCRIPTION	QTY
1	15403	BLAST ORIFICE FLAP	1
2	15401	MIDDLE FLAP	1
3	15400	FRONT FLAP	1
4	15402	REAR FLAP	2

PICKUP HEAD ASSEMBLY

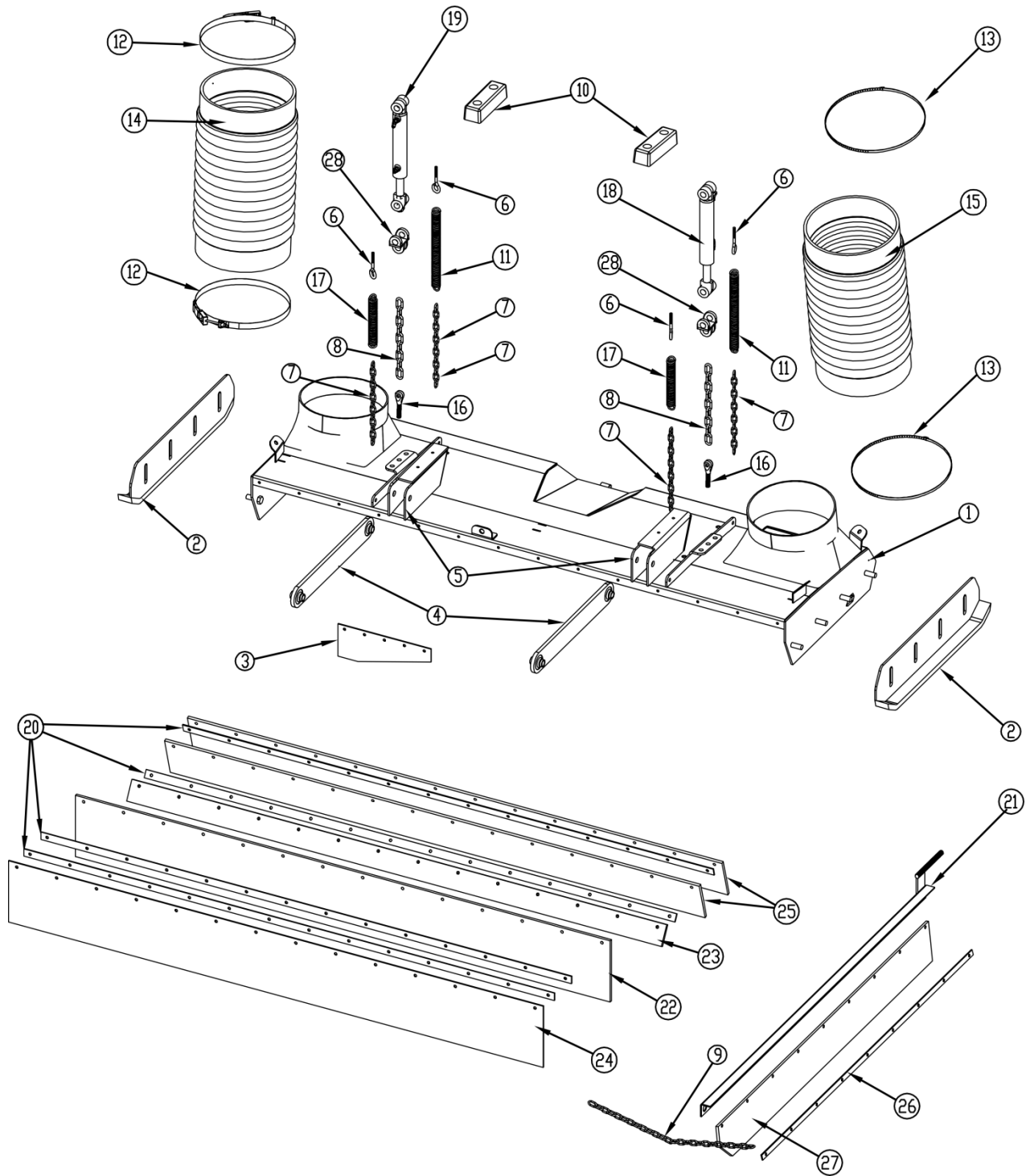

PICKUP HEAD ASSEMBLY

ITEM	PART #	DESCRIPTION	QTY
1	15404	HEAD CHANNEL	1
2	15405	DRAG SHOE	2
3	15406	HEAD INTAKE EXTENSION	1
4	15418	DRAG ARM	2
5	15412	HEAD MOUNTING BRACKET	1
6	1045	EYE BOLT	4
7	1137-07	CHAIN	4
8	1137-09	CHAIN	2
9	1137-26	CHAIN	1
10	9019	RUBBER BUMPER	2
11	9073	EXTENSION SPRING	2
12	9089	CLAMP	2
13	9161	HOSE CLAMP	2
14	9123	INTAKE TUBE STD	1
15	9135	INTAKE TUBE HEV	1
16	6133	CLEVIS BOLT	2
17	9109	EXTENSION SPRING	2
18	15413	CYLINDER	1
19	15414	CYLINDER	1
20	15415	BACKING STRIP	5
21	15407	DEFLECTOR FLAP WELDMENT	1
22	15401	MIDDLE FLAP	1
23	15403	BLAST ORIFICE FLAP	1
24	15400	FRONT FLAP	1
25	15402	REAR FLAP	3
26	15408	DEFLECTOR FLAP BACKING STRIP	1
27	15409	DEFLECTOR FLAP	1
28	15417	LINK	2
-	80211	HEAD FLAP KIT (ALL HEAD FLAP'S)	

REAR BUMPER ASSEMBLY

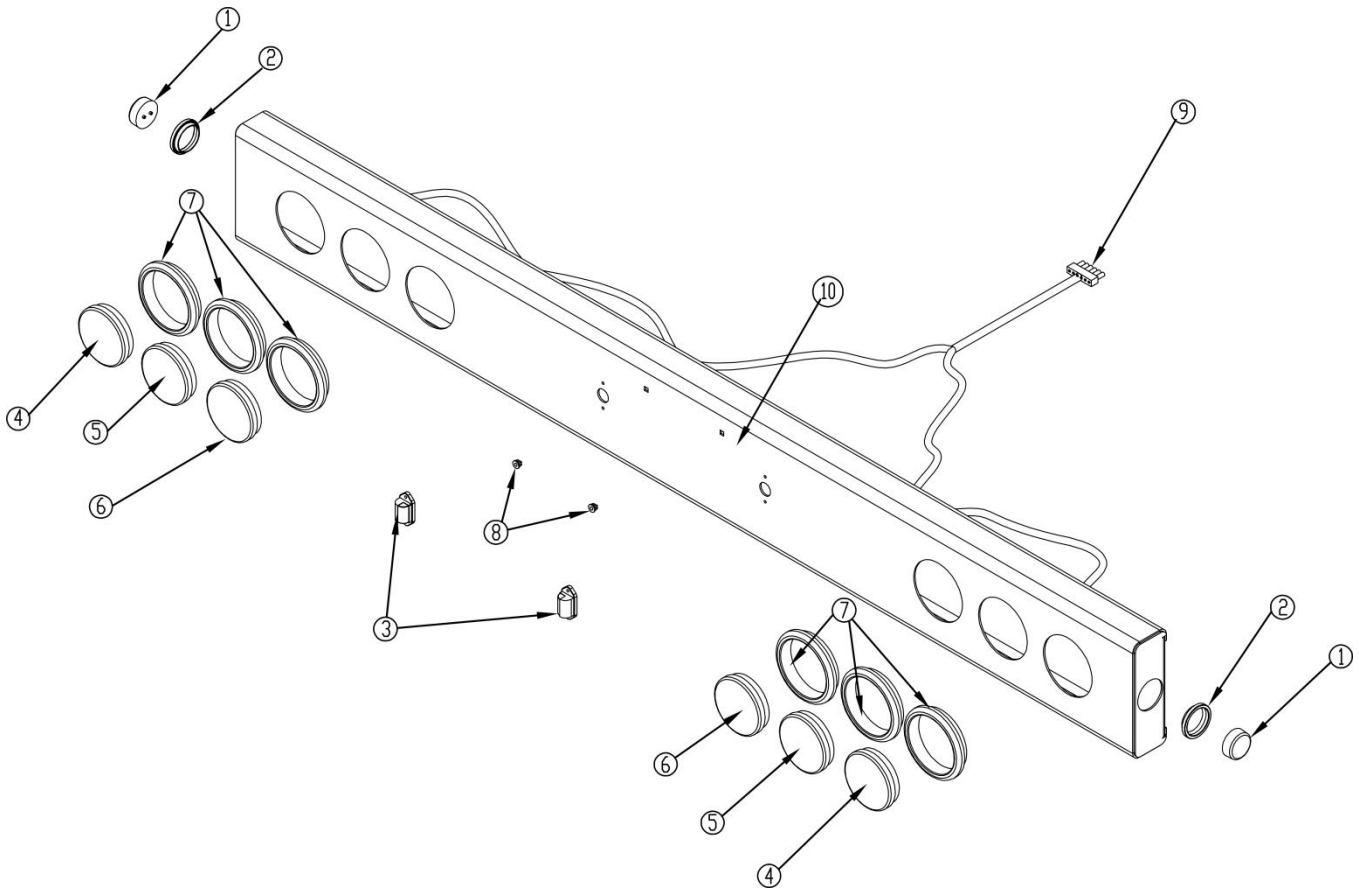

ITEM	PART #	DESCRIPTION	QTY
1	1028	CLEARANCE LIGHT (LED)	2
2	1131	GROMMET	2
3	1908	LICENCE LAMP	2
4	1909	BACKUP	2
5	1910	TURN AMBER	2
6	1911	BACK-UP	2
7	1912	GROMMET	6
8	9029	LICENSE PLATE SCREW RECEPTACLE	2
9	12517	BUMPER WIRING HARNESS	1
10	12500	REAR BUMPER	1

TOOL BOX ASSEMBLY

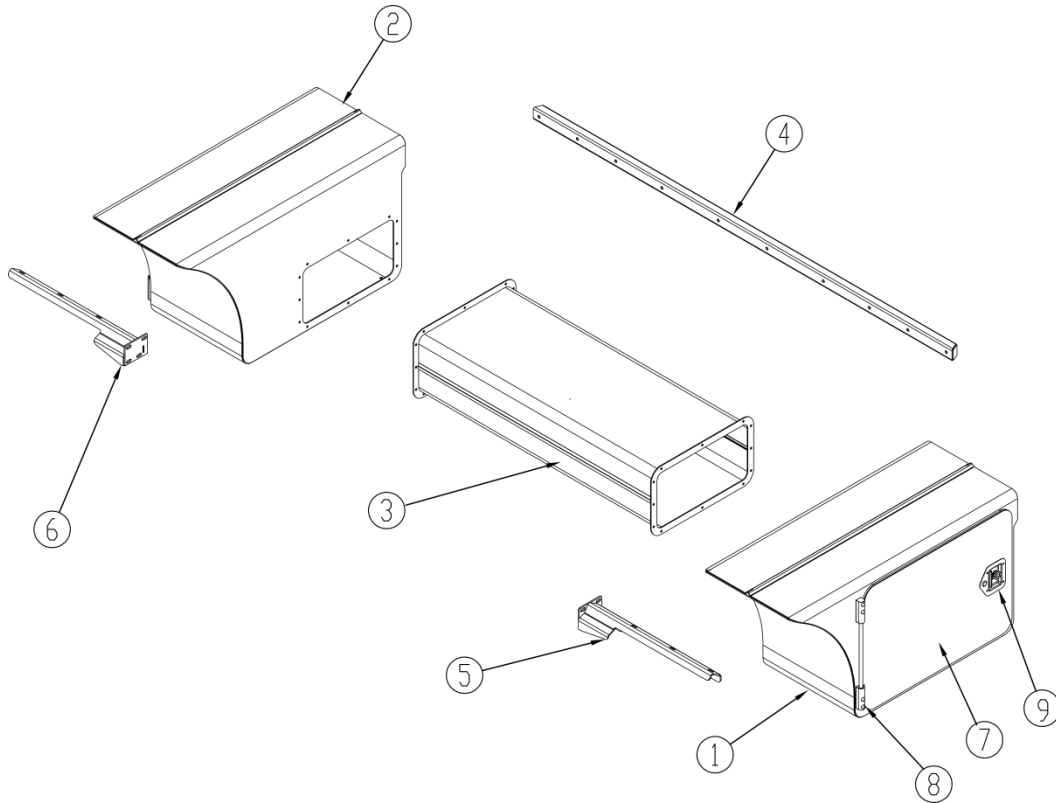

ITEM	PART #	DESCRIPTION	QTY
1	15600	LH TOOLBOX	1
2	15601	RH TOOLBOX	1
3	15602	CROSSOVER TUBE	1
4	15603	REAR MOUNTING TUBE	1
5	15604	LH FRONT MOUNT	1
6	15605	RH FRONT MOUNT	1
7	15606	TOOLBOX DOOR	2
8	15200	HINGE, ALUMINUM BLACK	4
9	9081	SS SHROUD LATCH	2

SHROUD ASSEMBLY

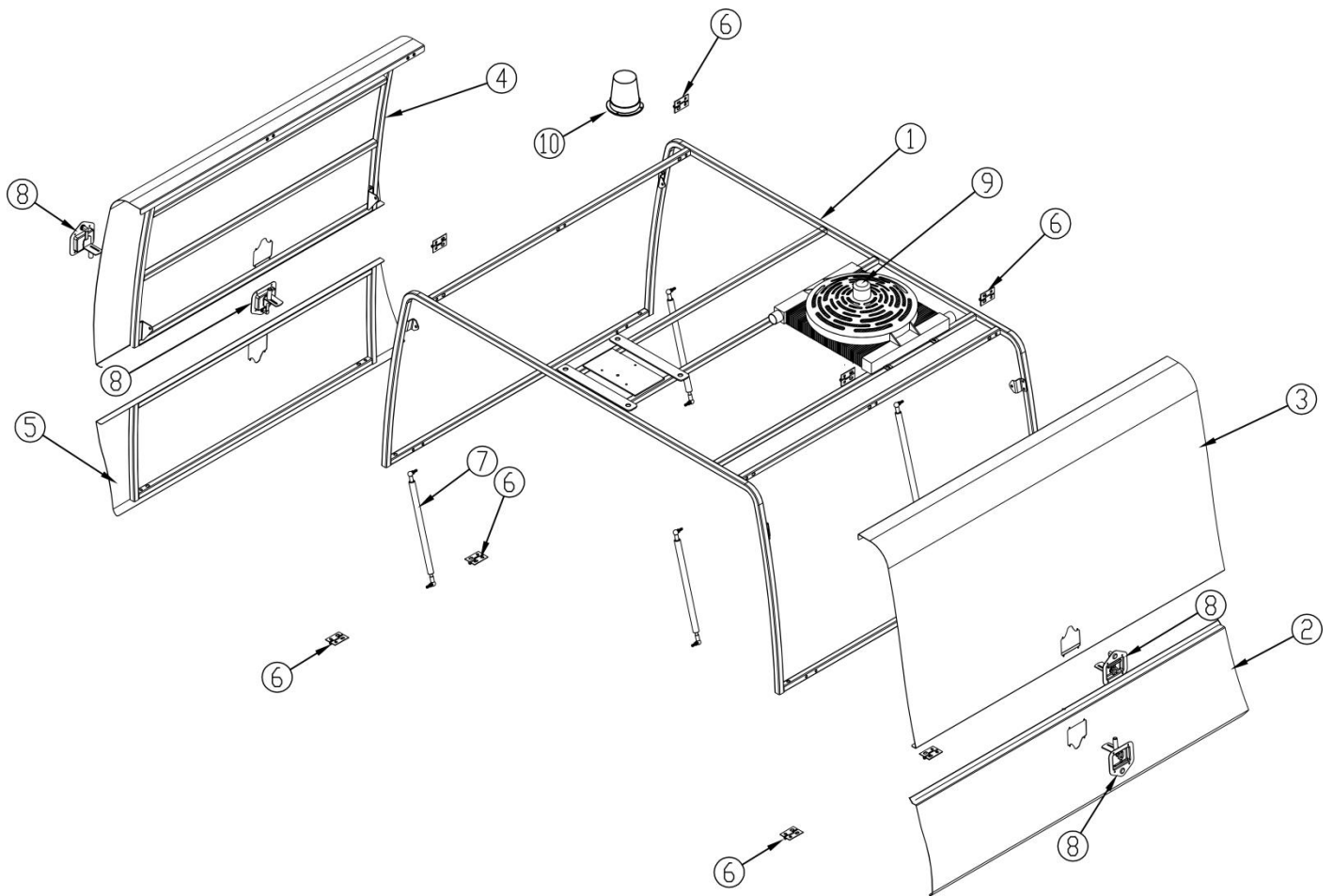

SHROUD ASSEMBLY

ITEM	PART #	DESCRIPTION	QTY
1	15300	SHROUD FRAME WELDMENT	1
2	80199	LH LOWER SHROUD DOOR	1
3	80198	LH UPPER SHROUD DOOR	1
4	80200	RH UPPER SHROUD DOOR	1
5	80201	RH LOWER SHROUD DOOR	1
6	15308	PIANO HINGE	6
7	9095	GAS SPRING 58#	4
8	9081	SHROUD LATCH	4
9	1955	HYDRAULIC COOLER	1
10	1916	STROBE	1
-	42107	LIMB GUARD (OPTIONAL)	

GUTTER BROOM UPPER SECTION ASSEMBLY

GUTTER BROOM UPPER SECTION ASSEMBLY

(QUANTITIES SHOWN ARE FOR ONE SIDE ONLY)

ITEM	PART #	DESCRIPTION	QTY
1	61201	GB MOUNT (LEFT HAND)	1
	61301	GB MOUNT (RIGHT HAND)	1
2	61213	PIN	1
3	1020	BUSHING	4
4	61203	GB PIVOT (LEFT)	1
	61303	GB PIVOT (RIGHT)	1
5	1506	NUT	5
6	141211	PIN	2
7	41215	SPRING BELL CRANK	1
8	1561	BOLT	1
9	1023	TURN BUCKLE	1
10	1505	NUT	1
11	1581	WASHER	1
12	1018	SUSPENSTION SPRING	2
13	41221	LINK	1
14	1540	BOLT	2
15	1570	WASHER	3
16	41205	LINKAGE MOUNT (LEFT)	1
	41316	LINK	1
17	1642	NUT	2
18	1640	NUT	1
19	1503	NUT	2
20	1022	TURN BUCKLE	2
21	1559	BOLT	5
22	1822	WASHER	3
23	1379	CYLINDER	2
24	1537	BOLT	3
25	1556	BOLT	2
26	1507	NUT	7
27	1508	NUT	1
28	1574	BOLT	1
29	1042	QUICK LINK	4
30	1019	RETRACT SPRING	1
31	1526	WASHER	2
32	1185	BUSHING	4
33	61235	RETRACT PLATE (LEFT)	1
	61335	RETRACT PLATE (RIGHT)	1
34	1560	BOLT	2
35	41230	EXTEND SPRING MOUNT	1
36	9137	LANYARD	2

GUTTER BROOM UNDER SECTION ASSEMBLY

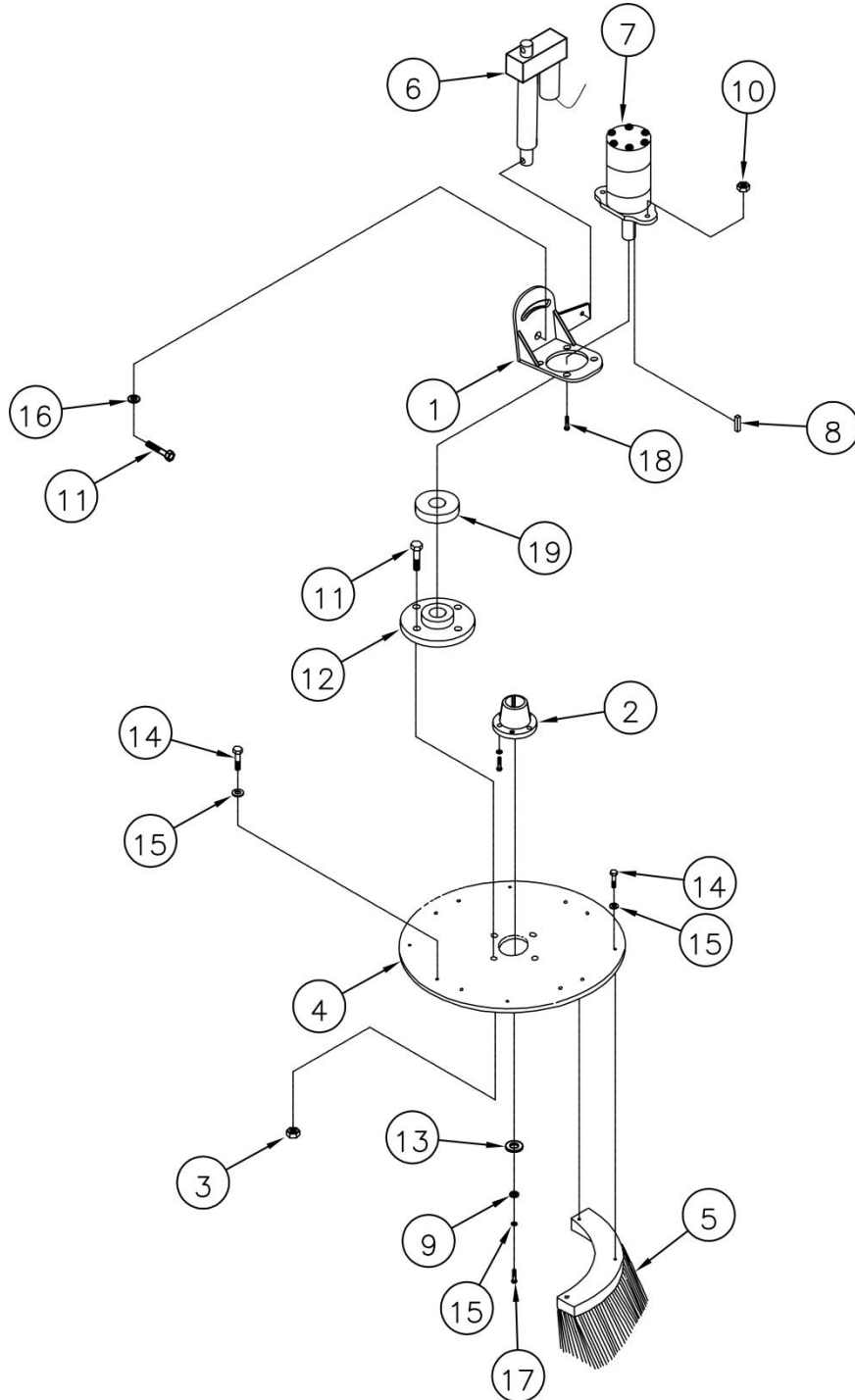

**GUTTER BROOM UNDER SECTION
ASSEMBLY**
(QUANTITIES SHOWN ARE FOR ONE SIDE ONLY)

ITEM	PART #	DESCRIPTION	QTY
1	41207	MOTOR BRACKET (LEFT)	1
	41318	MOTOR BRACKET (RIGHT)	1
2	3248	BUSHING C/W 3-BOLT, 3-LW	1
3	1506	NUT	4
4	41227	32" PLATE	1
5	1148	GB BRUSH SET	1
6	1078	LINEAR ACTUATOR	1
7	3243	MOTOR	1
8	1683	KEY	1
9	1822	WASHER	1
10	1505	NUT	2
11	1549	BOLT	4
12	41209	DRIVE HUB	1
13	1526	WASHER	1
14	1540	BOLT	24
15	1670	WASHER	5
16	1525	WASHER	2
17	1537	BOLT	3
18	1546	BOLT	2
19	42316	WASHER	2

WATER SYSTEM

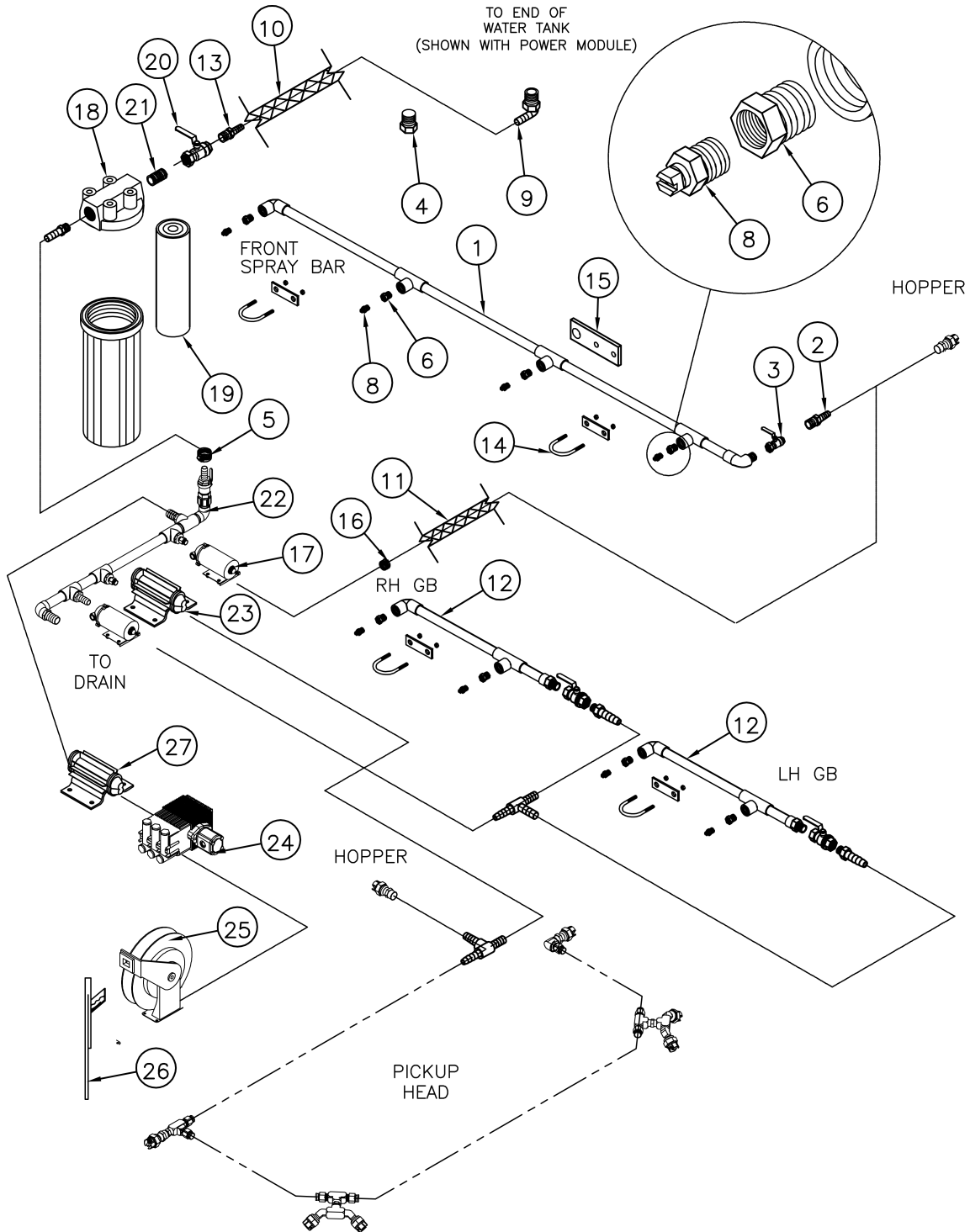

WATER SYSTEM

ITEM	PART #	DESCRIPTION	QTY
1	42201	SPRAY BAR	2
2	1158	HOSE BARB FITTING	4
3	1204	BALL VALVE	4
4	1185	PLUG	1
5	1203	HOSE CLAMP	10
6	9216	ADAPTER/NOZZLE ASSY	12
7	1163	HOSE BARB TEE ADAPTER	5
8	9217	NOZZLE	12
9	1130	WATER TANK ELBOW	1
10	1116	HOSE	35'
11	1166	HOSE	50'
12	62216	GB SPRAY BAR	2
13	1167	HOSE BARB FITTING	2
14	1168	U BOLT	8
15	42205	SPRAY BAR HANGER	4
16	1169	HOSE CLAMP	28
17	9035	WATER PUMP	2
18	1117	WATER FILTER HOUSING	1
19	1172	WATER FILTER ELEMENT	1
20	1159	BALL VALVE	1
21	1160	NIPPLE	1
22	15026	WATER PUMP DISTRIBUTION BAR	1
23	3232	WATER PUMP	1
OPTIONAL PRESSURE WASHER			
24	2081	PRESSURE WASHER PUMP	1
25	2083	REEL	1
26	80223	WAND KIT	1
27	1076	12 VOLT 7 GPM WATER PUMP	1

42527 ENGINE CONTROL BOX LAYOUT

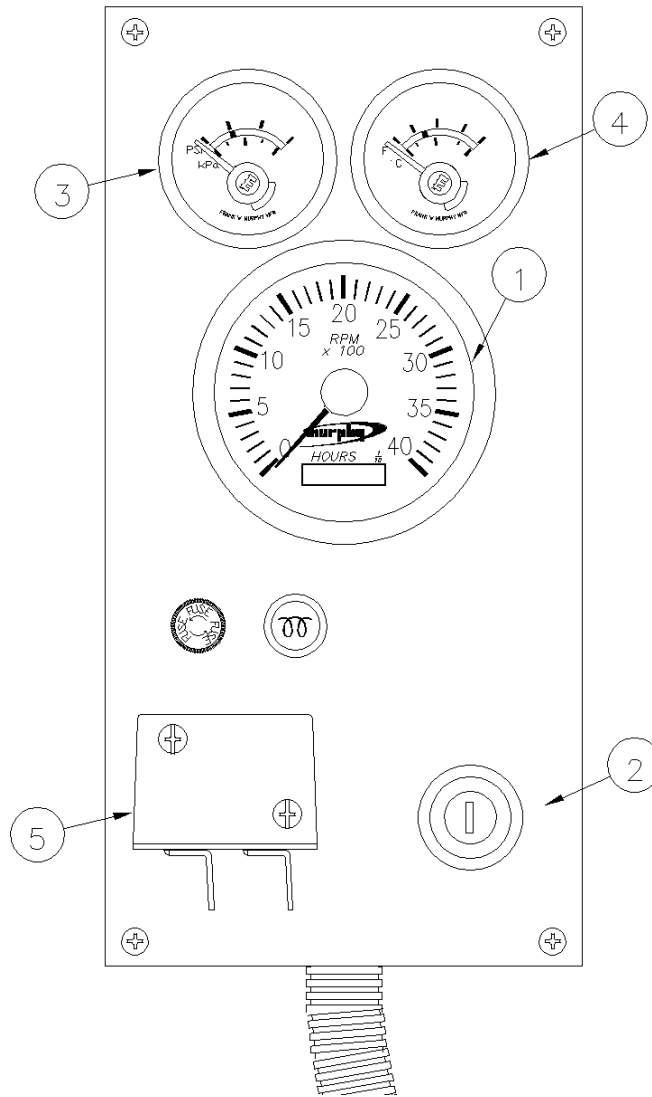

ITEM	PART #	DESCRIPTION	QTY
1	1092	TACH/HOUR METER	1
2	1095	IGNITION SWITCH	1
3	1090	OIL PRESSURE GAUGE	1
4	1091	WATER TEMP GAUGE	1
5	1094	SHUT DOWN MODULE	1

ENGINE CONTROL BOX SCHEMATIC

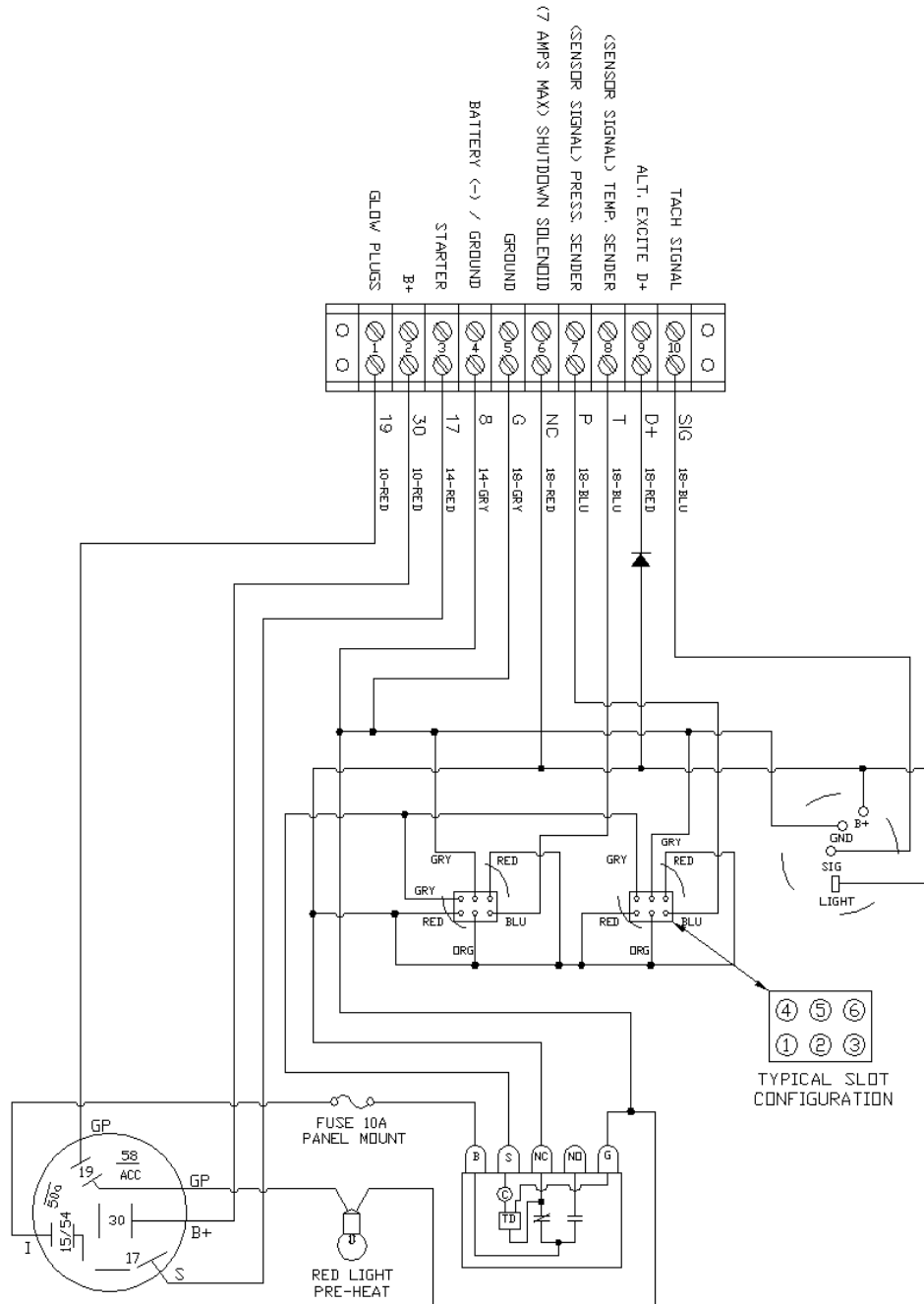

80209 SWEEPER CONTROL PANEL

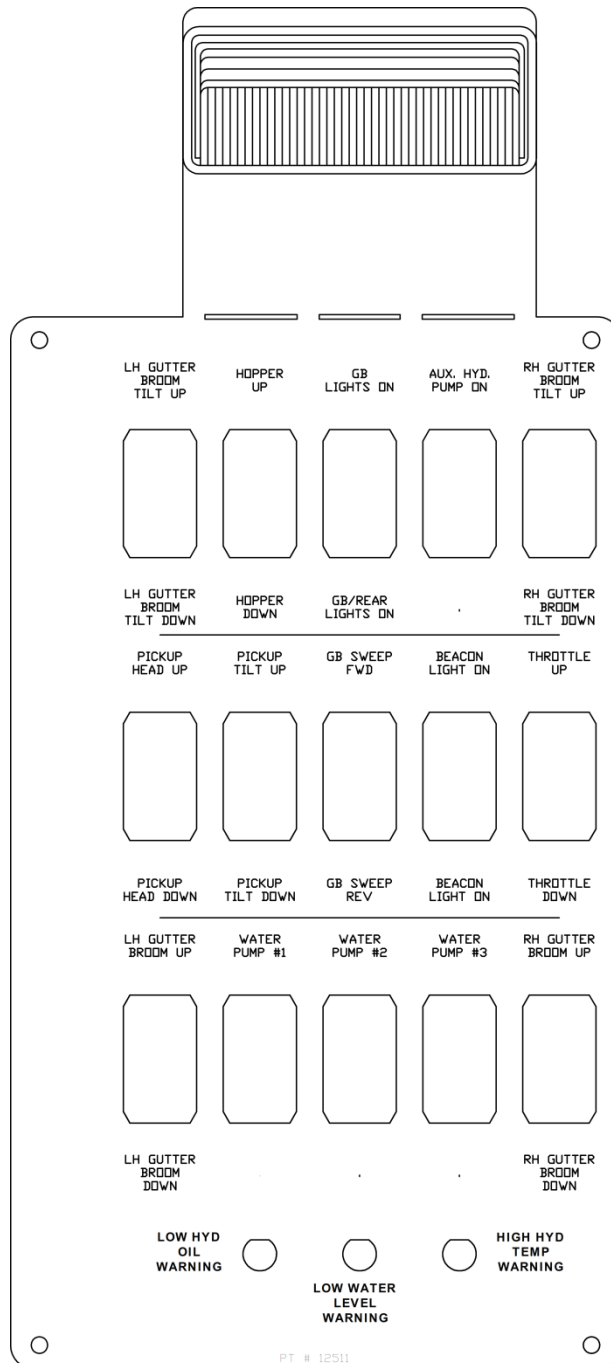

80209 SWEEPER CONTROL PANEL

ITEM	PART #	DESCRIPTION	QTY
1	1101	SHOCK MOUNT	4
2	62505	BOX	1
3	12510	PANEL	1
4	12511	PANEL DECAL	1
5	1947	RELAYS (NOT SHOWN)	7
6	12515	HARNESS	1
7	1686	SWITCH (M-O-M)	5
8	1684	SWITCH (S-O-S)	6
9	1685	SWITCH (S-O-M)	3
10	1689	HOLE PLUG	2
11	1969	RED SWITCH COVERS	14
12	1968	GREEN SWITCH COVERS	1
13	62511	SWITCH BOX HARNESS	1
14	1971	PCB	1
15	1691	LED	2
16	1796	MAP LIGHT	1
17	1769	CAMERA MONITOR SYS	1

CAB PANEL MOUNTING

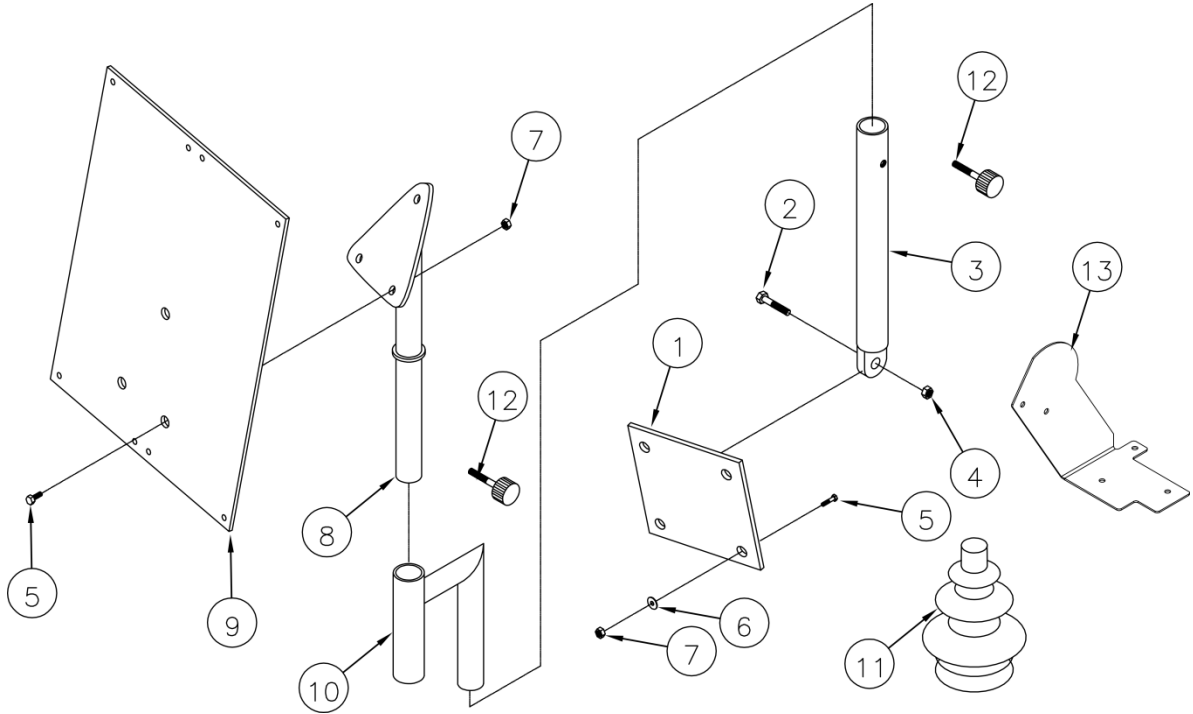

ITEM	PART #	DESCRIPTION	QTY
1	42501	ADAPTER PLATE	1
2	1546	BOLT	1
3	42502	SUPPORT POST	1
4	1505	NUT	1
5	1531	BOLT	7
6	1520	WASHER	4
7	1501	NUT	7
8	42503	TOP MOUNT	1
9	42506	BOX MOUNT PLATE	1
10	42510	OFFSET POST	1
11	1233	ELECT. BOOT	1
12	1194	PEDISTAL KNOB	2
13	15809	BLEEDER DOOR CONTROL MOUNT	1

80207 AUXILIARY CONTROL BOX LAYOUT

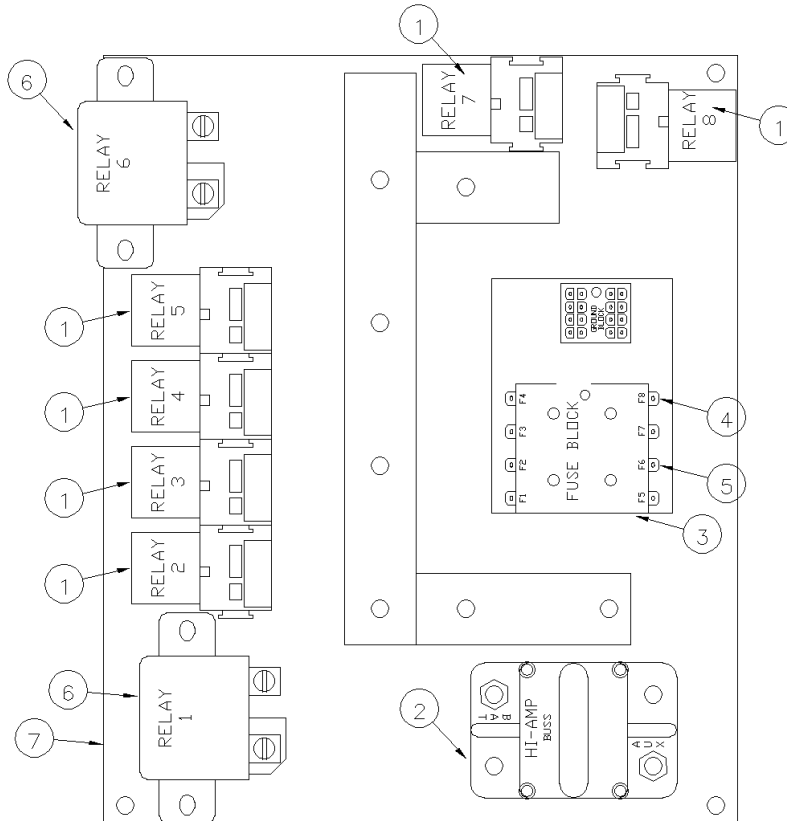

ITEM	PART #	DESCRIPTION	QTY
1	1947	RELAY	6
2	2043	CIRCUIT BREAKER	1
3	2041	FUSE HOLDER 8 POSITION	1
4	2042	FUSE 15 AMP F1-5/7/8	7
5	1193	FUSE 5 AMP F6	1
6	1946	RELAY	2
7	62507	AUX BOX MOUNTING PLATE	1
8	12512	HARNESS (NOT SHOWN)	1

12512 AUXILIARY CONTROL BOX SCHEMATIC

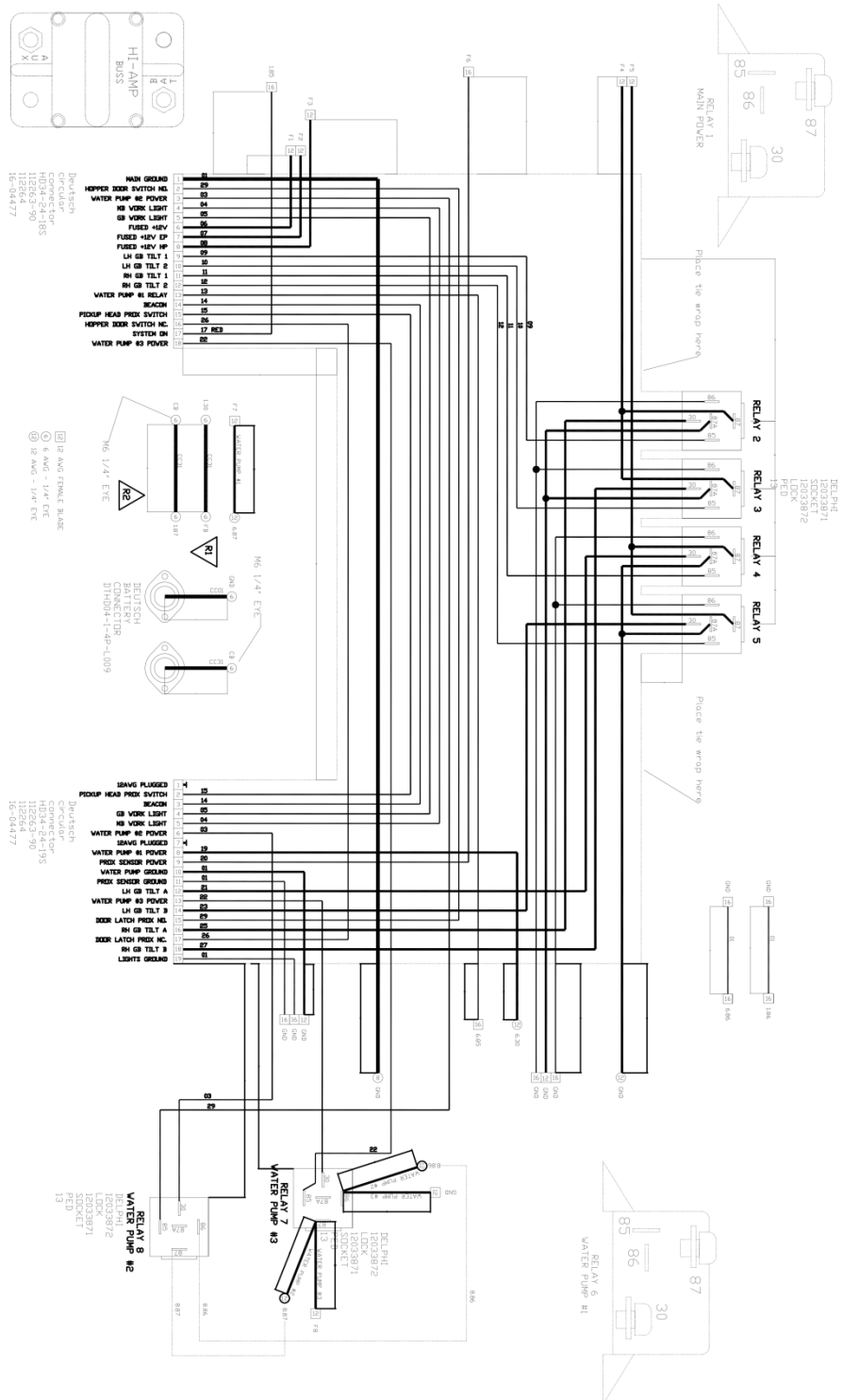

12514 VALVE HARNESS SCHEMATIC

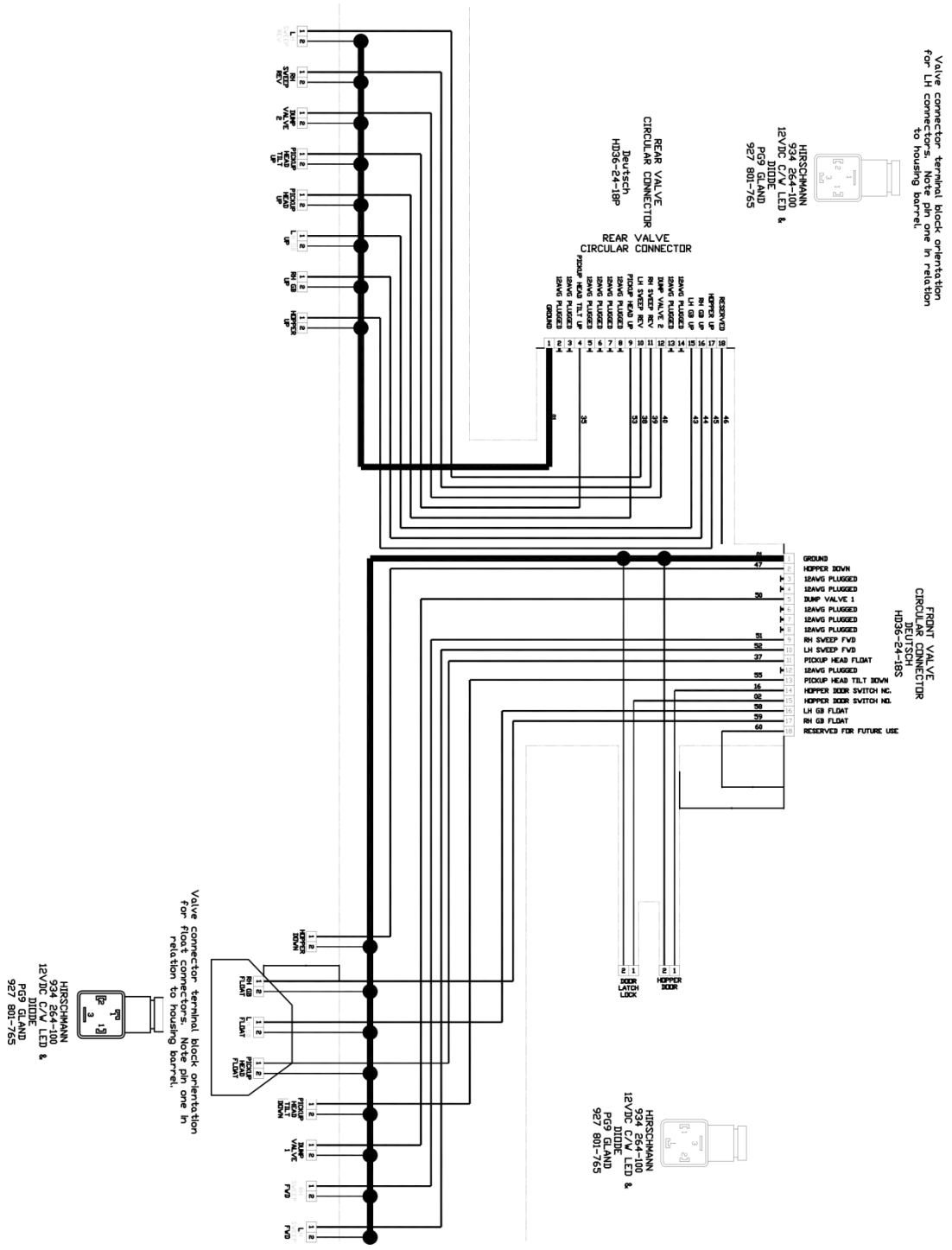

12513
BODY HARNESS
SCHEMATIC

12515 SWITCH BOX HARNESS SCHEMATIC

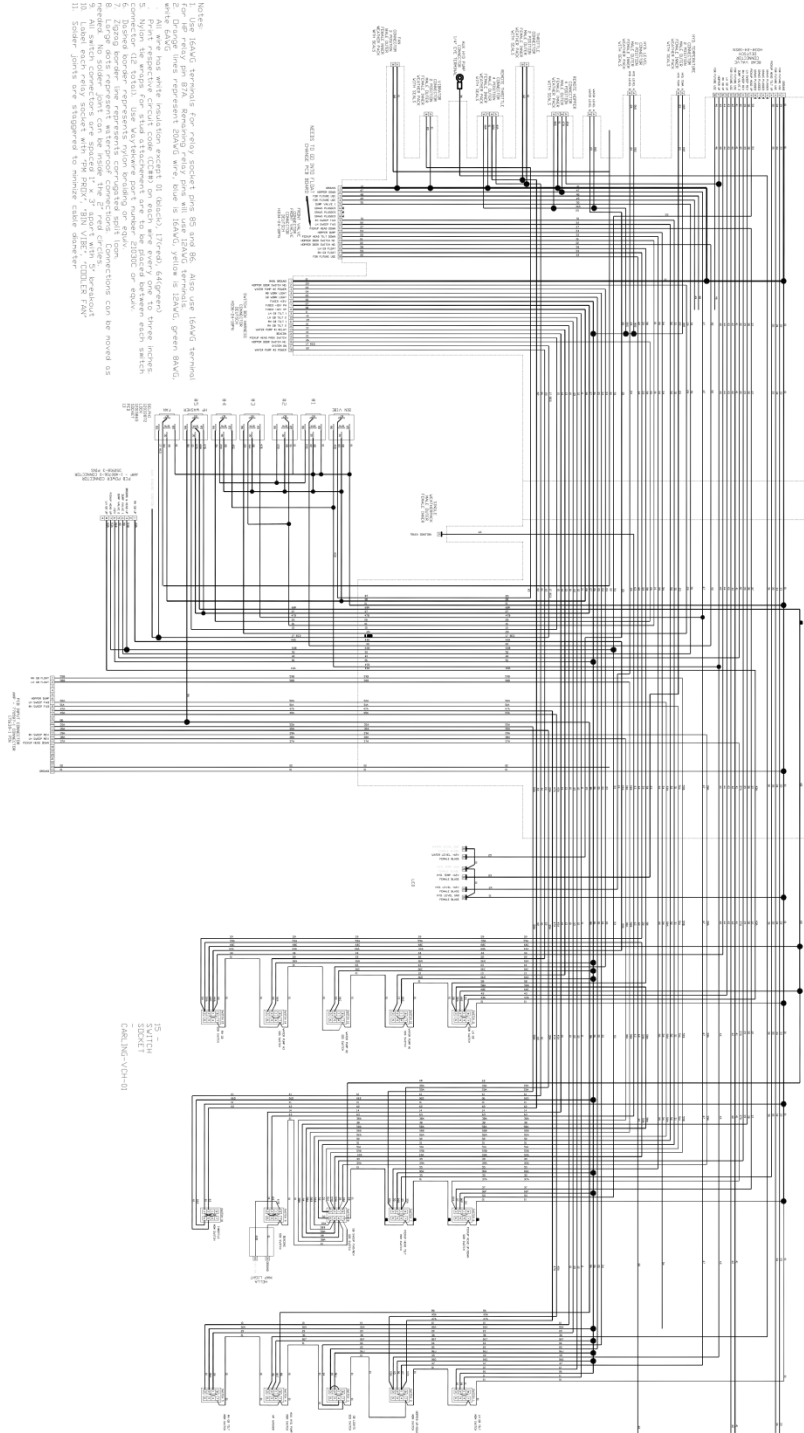

12517 BUMPER HARNESS SCHEMATIC

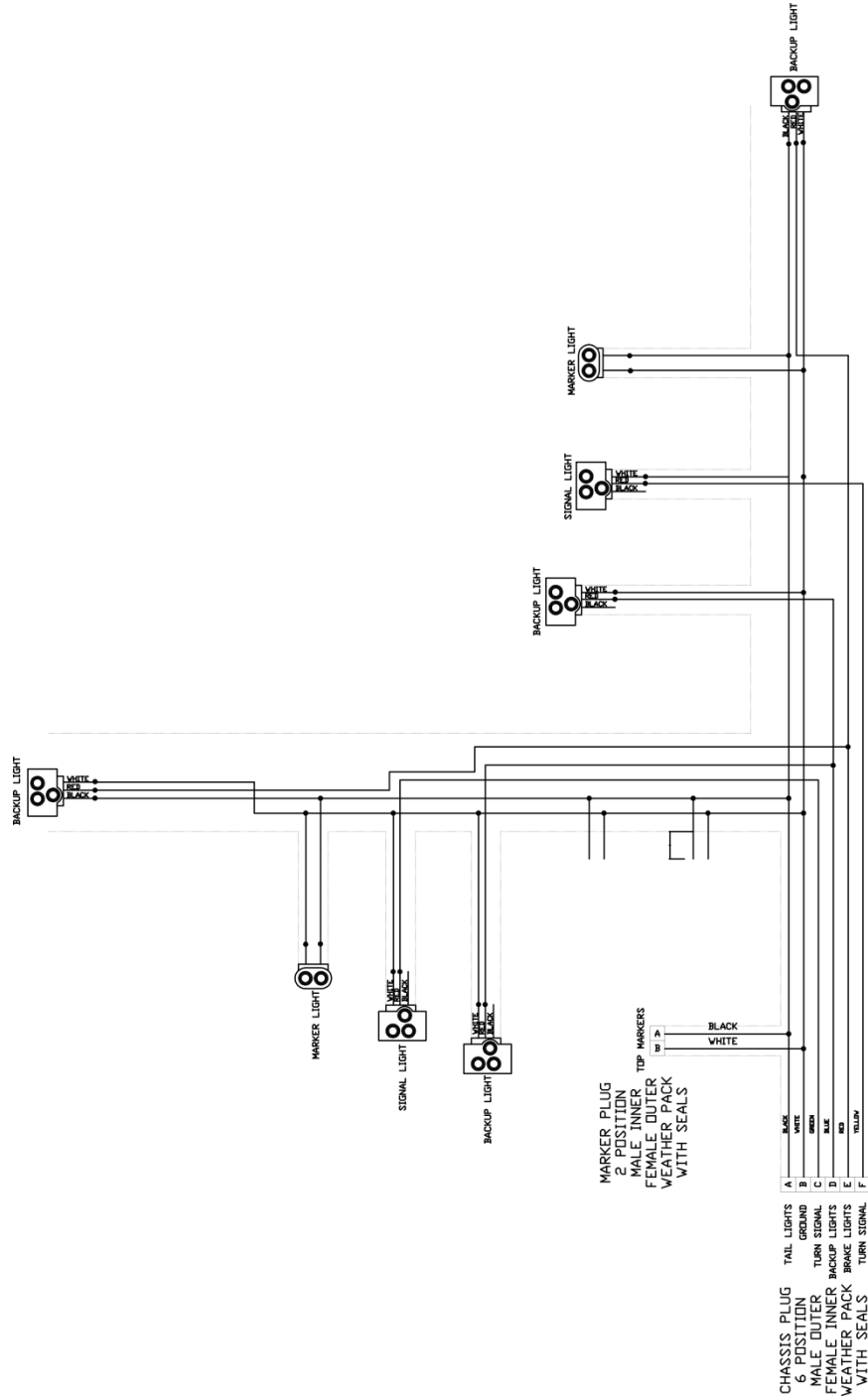

12518 TOP MARKER HARNESS SCHEMATIC

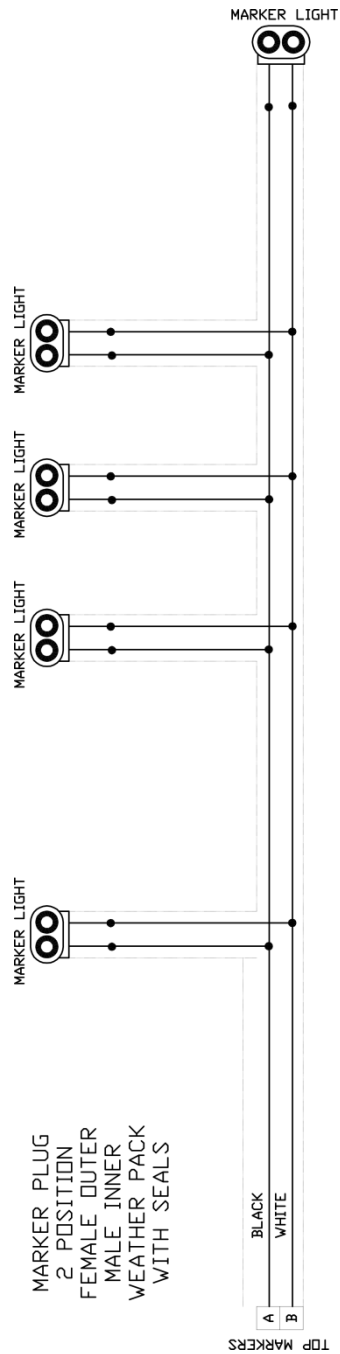

12519 TOP BEACON HARNESS SCHEMATIC

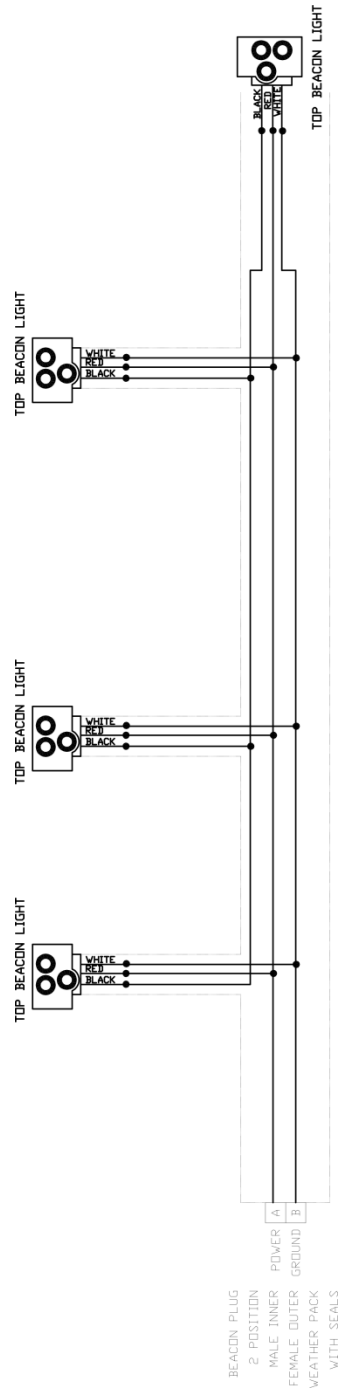



**HAND HOSE
ASSEMBLY
(OPTIONAL)**

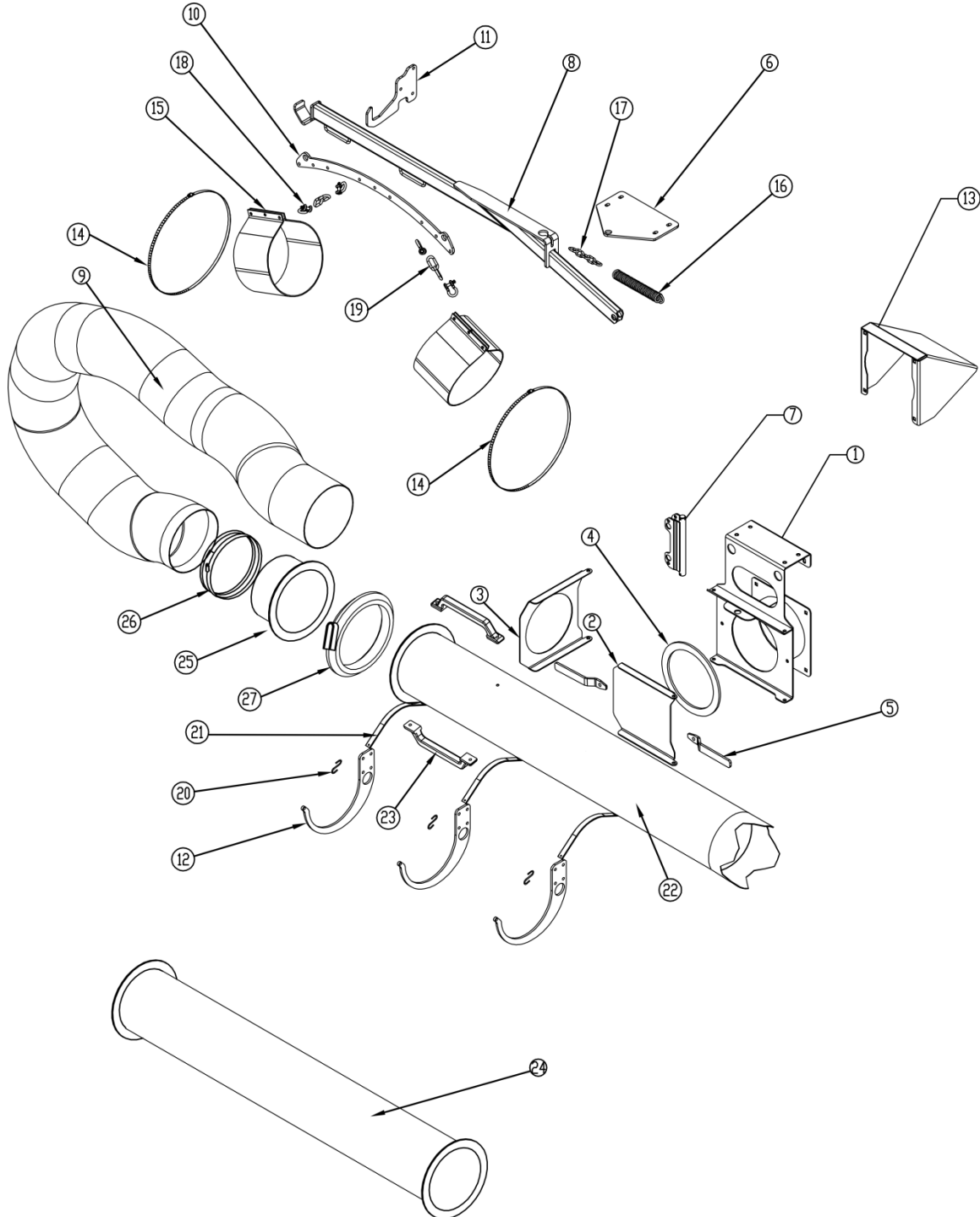

HAND HOSE ASSEMBLY

ITEM	PART #	DESCRIPTION	QTY
1	15700	MOUNTING BRACKET	1
2	15702	COVER DOOR	1
3	15701	TRANSITION DOOR	1
4	9072	RUBBER SEAL	1
5	15703	LATCH HANDLE	2
6	15704	UPPER HINGE PLATE	1
7	15705	PIVOT BRACKET	1
8	15714	SPRING BOOM ARM	1
9	9113	8" HAND HOSE SECTION	1
10	15707	BRIDGE PLATE	1
11	15708	BOOM ARM REST	1
12	15709	HOSE BRACKET	3
13	15710	DEFLECTOR REAR DOOR	1
14	9134	HOSE CLAMP	2
15	15711	RUBBER HANGER	2
16	9109	EXTENSION SPRING	1
17	9059	3/16 CHAIN	1
18	9082	SHACKLE	4
19	9058	CHAIN LINK	2
20	9118	S-HOOK	3
21	9119	BUNGEE STRAP	3
22	9267	WAND TUBE	1
23	9116	PLASTIC HANDLE	2
24	9266	WAND EXTENSION (OPTIONAL)	1
25	9268	HOSE CONNECTION FLANGE	1
26	9269	HOSE CLAMP	1
27	9269	HOSE CLAMP (2 NEEDED FOR EXTENSION)	1

R-6 DECALS

To Order:

CALL toll free: 800-482-2302

Call Direct: 717 901-5600

[7am to 5pm eastern]

Send Fax: 717-901-2326

[24/7/365]

Email: parts@stewart-amos.com



PT # 43201 10/UNIT



PT # 43205 4/UNIT



PT # 43207 3/UNIT



PT # 43211 4/UNIT

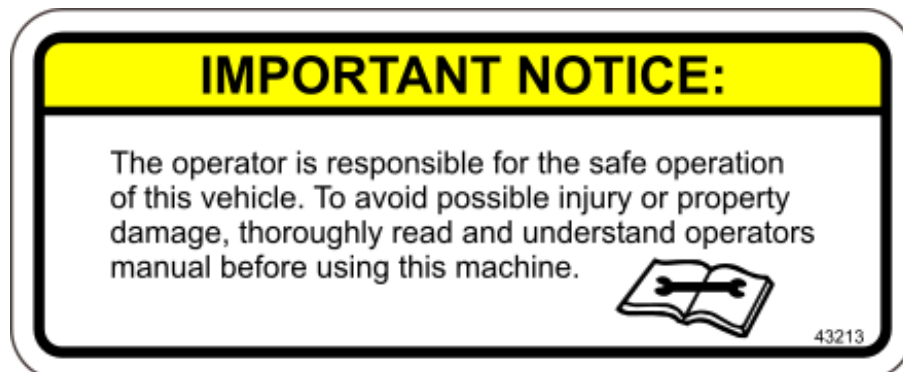

PT # 43213 1/UNIT



PT # 43215 6/UNIT



PT # 43217 2/UNIT



PT # 43219 1/UNIT



PT # 43221 1/UNIT



PT # 43223 5/UNIT

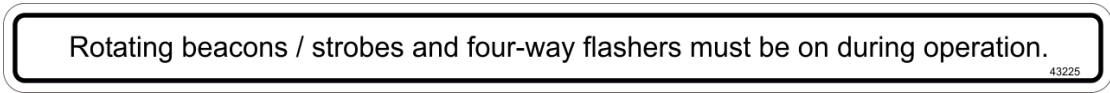

PT # 43225 1/UNIT

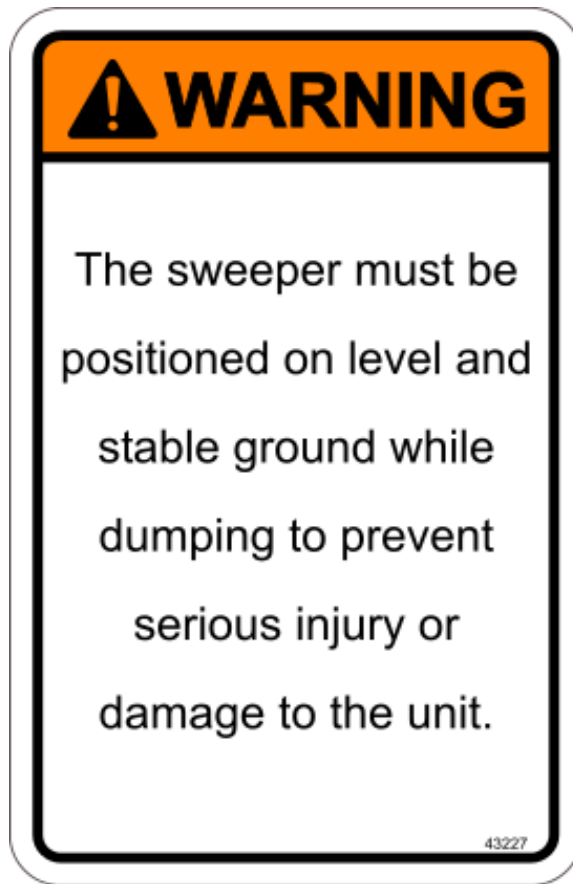

PT # 43227 2/UNIT

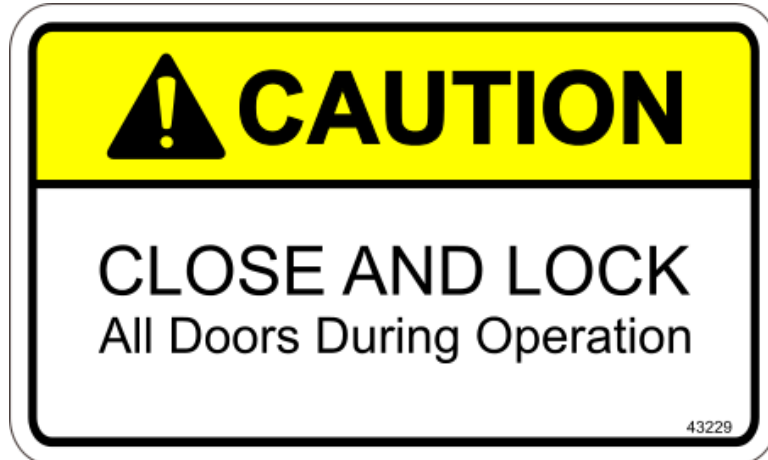

PT # 43229 7/UNIT

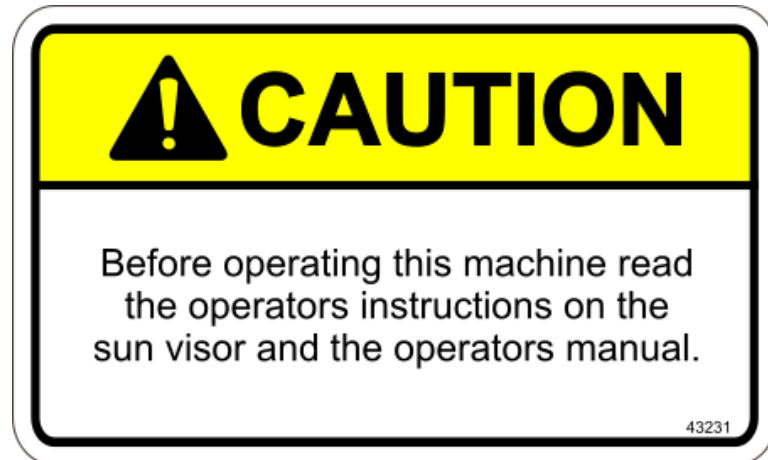

PT # 43231 1/UNIT



PT # 43233 2/UNIT

WATER ONLY

PT # 43235 1/UNIT

DUMP ON LEVEL GROUND ONLY

43237

PT # 43237 1/UNIT

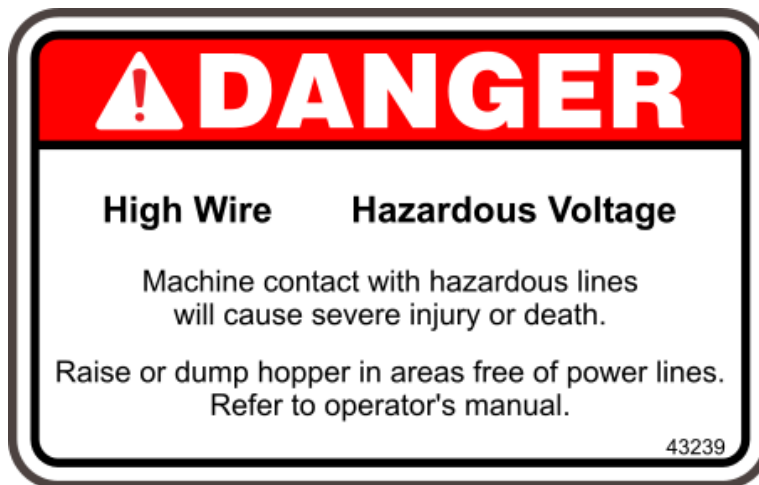

PT # 43239 1/UNIT

Driving at low speeds for sustained periods of time may overheat the transmission fluid. Driver should select "L" position during low speed operation, under 11mph (18kmh)

PT # 43244 1/UNIT

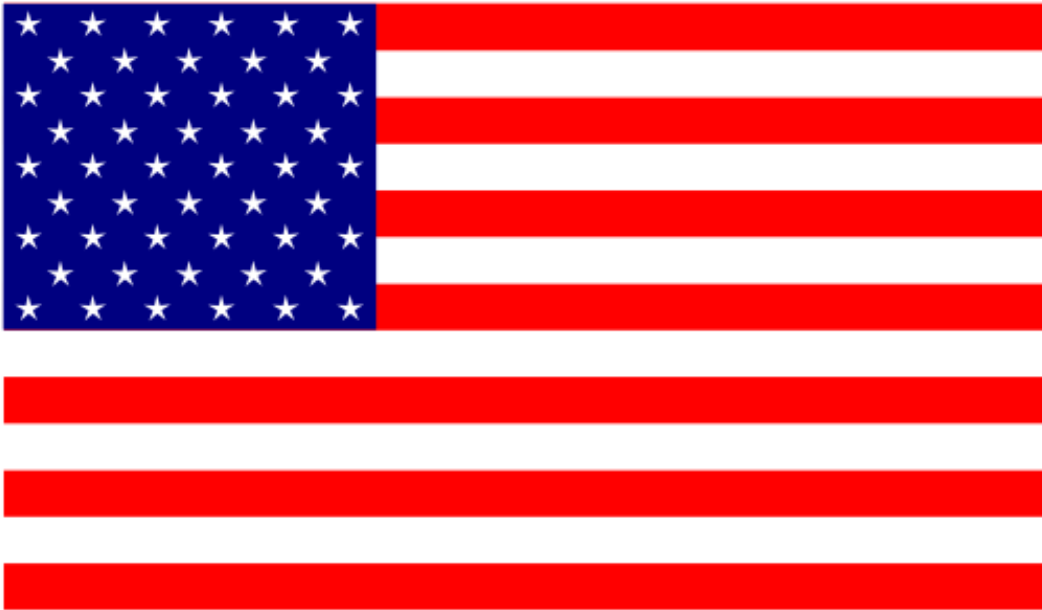

PROUDLY MADE IN THE U.S.A.

PT # 43245 1/UNIT



GALAXY R-6

PT # 43263 1/UNIT



GALAXY R-6

PT # 43258 1/UNIT



PT # 43254 1/UNIT

SA
STEWART-AMOS
Sweeper Co.

PT # 43262 1/UNIT



PT # 43255 1/UNIT



PT # 43256 1/UNIT

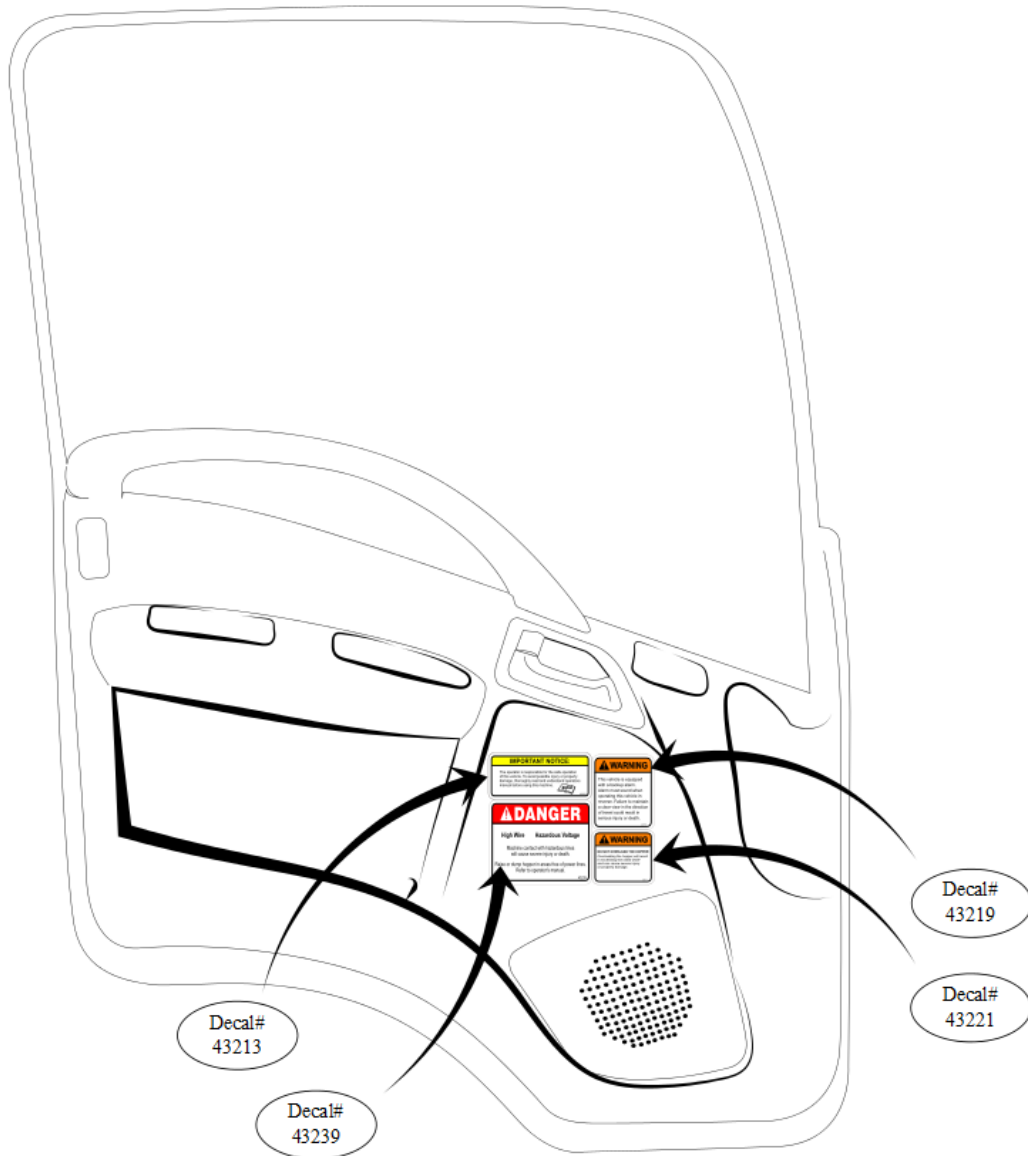

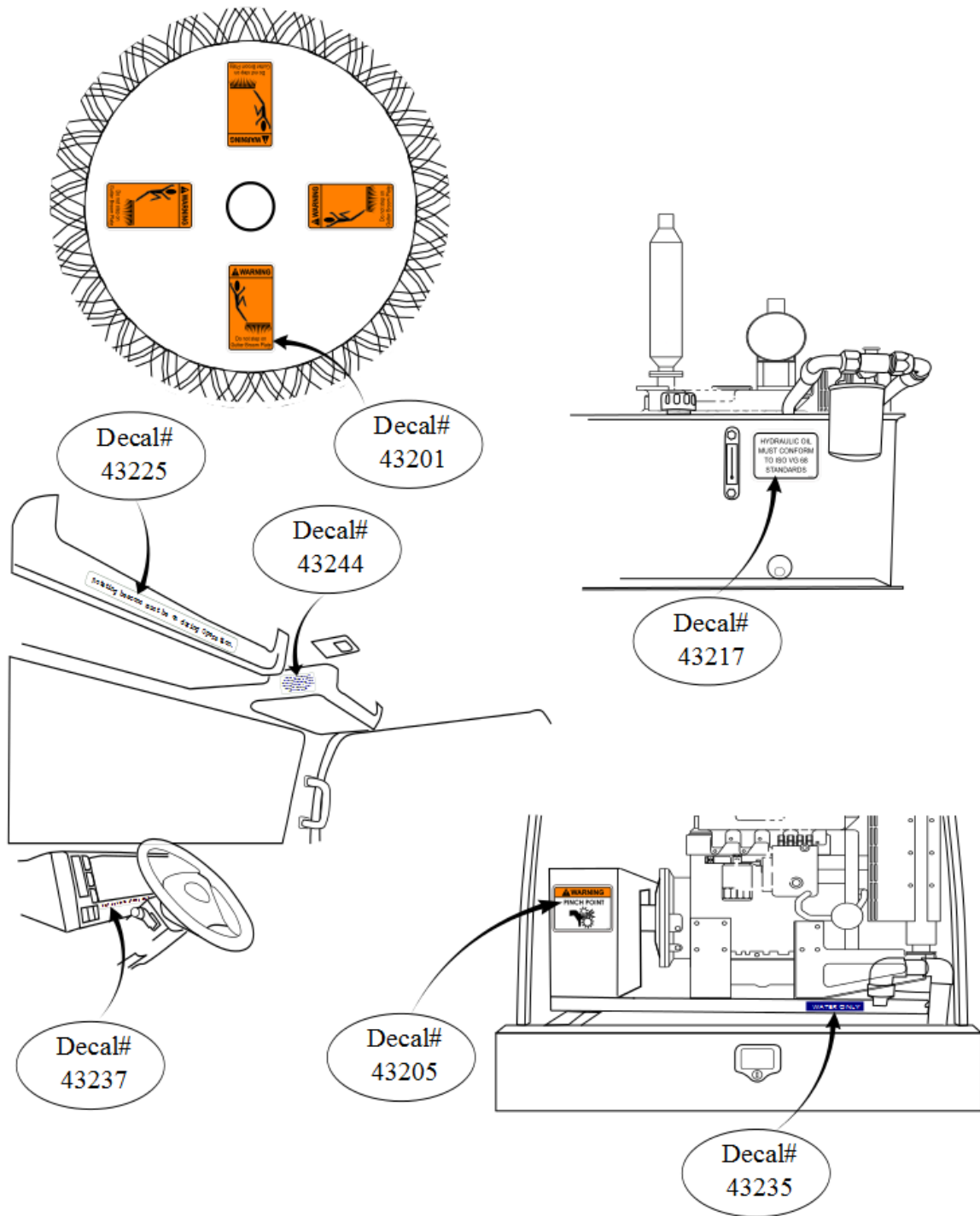

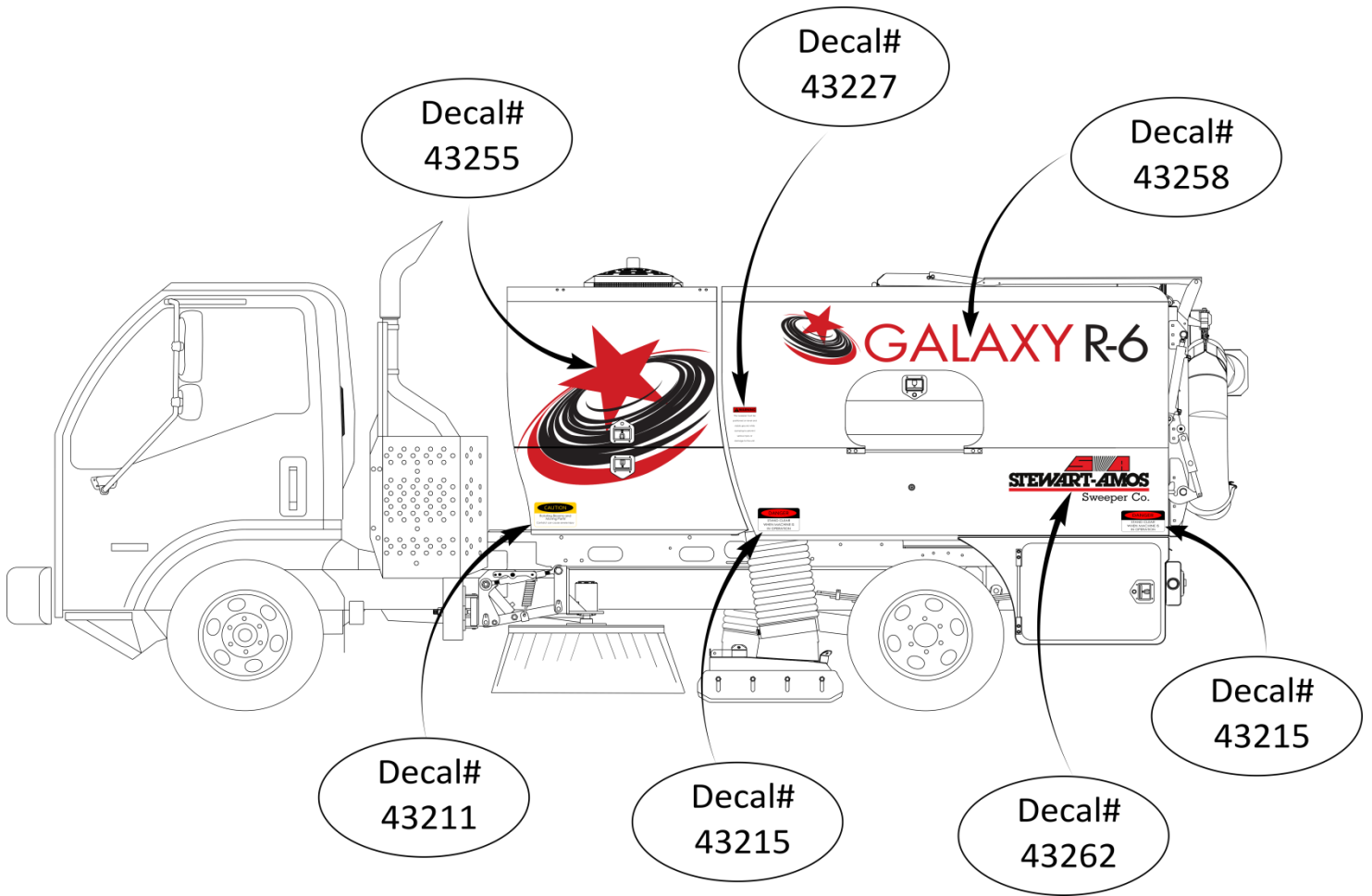

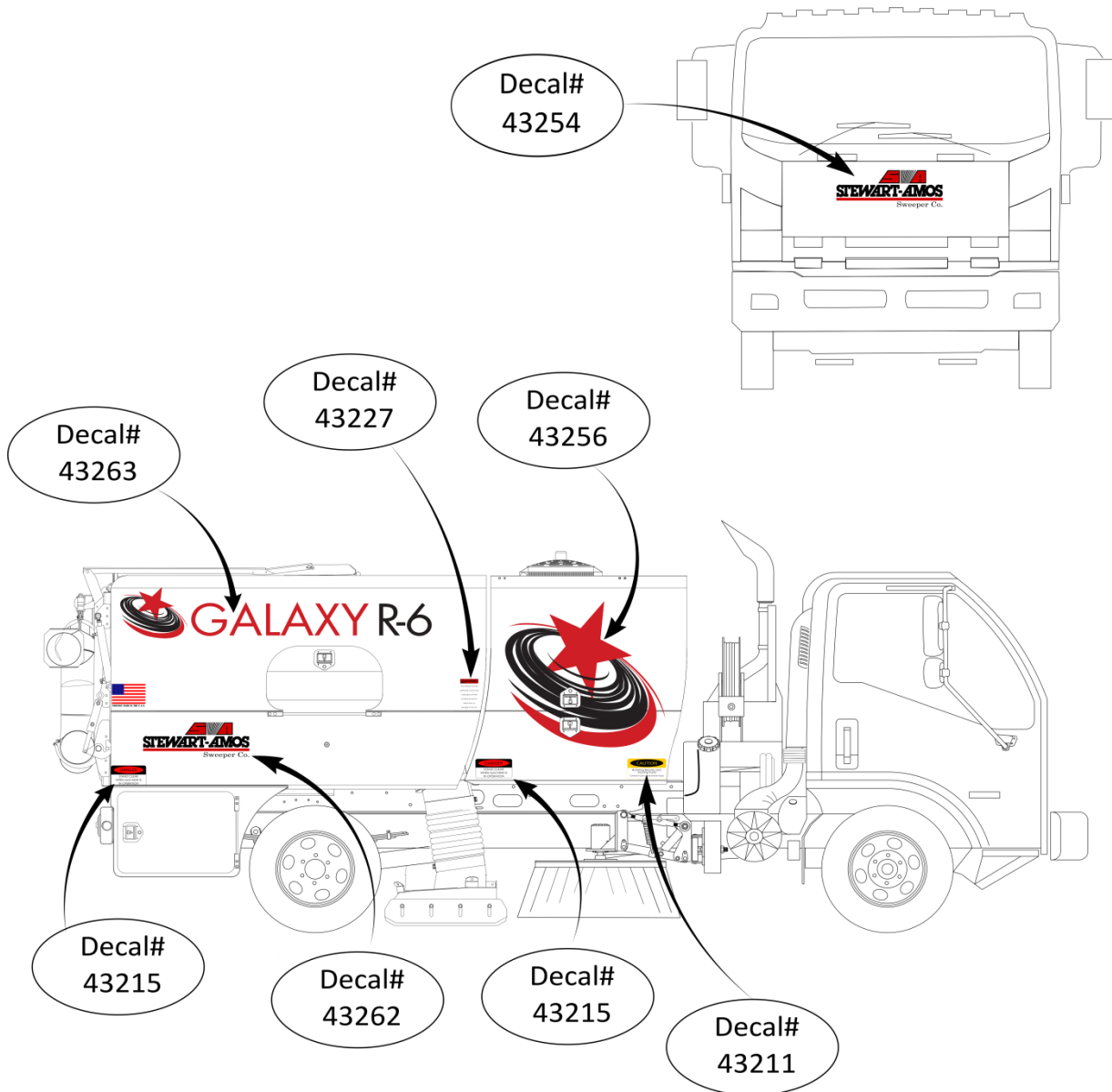

80216		SAFETY DECAL KIT	
	10	43201	DO NOT STEP
	4	43205	PINCH POINT
	3	43207	DANGER SAFETY SUPPORT IN PLACE
	4	43211	CAUTION ROTATING BROOMS
	1	43213	IMPORTANT OPERATOR IS RESPONSIBLE
	6	43215	DANGER STAND CLEAR
	2	43217	HYDRAULIC OIL MUST CONFORM
	1	43219	WARNING THIS VEHICLE IS EQUIPED
	1	43221	WARNING DO NOT OVERLOAD
	5	43223	SAFETY SUPPORT
	1	43225	ROTATING BEACONS AND STROBES
	2	43227	WARNING SWEEPER MUST BE LEVEL
	7	43229	CAUTION CLOSE AND LOCK
	1	43231	CAUTION BEFORE OPERATING
	2	43233	PINCH POINT Strp
	1	43235	WATER ONLY
	1	43237	DUMP ON LEVEL GROUND ONLY
	1	43239	DANGER HIGH WIRE HAZARD VOLTAGE
	1	43244	LOW SPEED WARNING
	1	43245	MADE IN USA

80221		R-6 DECAL KIT	
	1	43254	Lg STEWART-AMOS DECAL
	1	43255	R-4/R-6 LH Lg GALAXY LOGO
	1	43256	R-4/R-6 RH Lg GALAXY LOGO
	1	43258	LH R-6 GALAXY DECALS & LOGO ON SIDES
	1	43263	RH R-6 GALAXY DECALS & LOGO ON SIDES
	1	43237	DUMP ON LEVEL GROUND ONLY
	2	43262	SM STEWART-AMOS DECALSIDES
	1	43254	Lg STEWART-AMOS DECAL

INDEX BY PAGE

PT #	DESCRIPTION	QTY	PG #
9066	RUBBER EDGE TRIM 17"	4	106
9122	DUMP CYLINDER	2	106
9129	INTAKE TRANSITION SEAL	1	106
15100	BOLT PLATE TRANSITION	1	106
15101	MAIN FRAME WELDMENT	1	106
15102	REAR BUMPER MOUNTING BRACKET	1	106
15103	TRANSITION MOUNTING BRACKET	1	106
15104	MIDDLE TIE DOWN MAIN FRAME	2	106
15105	HEAD SPRING HANGER	2	106
15106	HEAD SPRING HANGER	4	106
15107	R-6 DRAG ARM BRACKET	2	106
15108	4 INTAKE TRANSITION TUBE WELDMEN	1	106
15109	HINGE BOLT ASSY R-6 MAIN FRAME	2	106
15110	SAFTY CHAULK HOPPER DUMP	2	106
9169	BLEEDER DOOR CABLE	1	108
15000	R-6 MOUNTING PLATE PM	2	108
15001	R-6 POWER MODULE WELDMENT	1	108
15004	WATER RESERVOIR 200 GAL	1	108
15005	HYDRANT FILL TUBE WELDMENT	1	108
15015	FUEL FILLER BRACKET	1	108
62512	AUX BOX	1	108
80183	HYDRAULIC RESERVOIR	1	108
80187	FAN ASSEMBLY	1	108
80189	ENGINE SKID ASSEMBLY	1	108
80210	HYDRAULIC VALVES	1	108
1299	THROTTLE GUIDE	1	110
1387	THROTTLE ACTUATOR	1	110
1388	THROTTLE ACTUATOR CABLE	1	110
2071	ENGINE	1	110
2072	DRIVE	1	110
2073	COUPLING	1	110
2074	HYDRAULIC PUMP	1	110
2254	MUFFLER FLANGE	1	110
2257	ALTERNATOR (NOT SHOWN)	1	110
2258	STARTER (NOT SHOWN)	1	110
2259	FUEL FILTER (NOT SHOWN)	1	110
2260	SOLENOID (NOT SHOWN)	1	110
2262	AIR CLEANER	1	110
2264	COVER	1	110
2267	FILTER PRIMARY	1	110
2268	FILTER SECONDARY	1	110
2271	INLET HOOD	1	110
2272	MOUNTING BAND	1	110
2276	MUFFLER	1	110
2277	STACK CAP	1	110

PT #	DESCRIPTION	QTY	PG #
2278	MUFFLER MOUNTING BAND	1	110
9017	BEARING	1	110
9031	BUSHING	2	110
9086	PULLEY	1	110
9087	PULLEY	1	110
9094	BELT	1	110
9096	VIBRATION ISOLATOR	6	110
9108	FAN SHAFT	1	110
15006	SLIDE BAR ENGINE SKID	2	110
15007	ENGINE SKID	1	110
15008	BELT GUARD	1	110
15009	HEAD WASHER	6	110
15010	TAIL WASHER	6	110
15021	THROTTLE ARM	1	110
15801	PUMP MOUNT	1	110
9076	HOSE CLAMP (NOT SHOWN)	1	112
9084	CLAMPING U-BOLT	2	112
9102	FIRE HOSE (NOT SHOWN)	1	112
9103	KING NIPPLE (NOT SHOWN)	1	112
9104	ASS HYDRANT COUPLING (NOT SHOW	1	112
9105	QUICK DISCONNECT	1	112
9106	QUICK DISCONNECT (NOT SHOWN)	1	112
9107	ALUMINUM DUST CAP (NOT SHOWN)	1	112
15005	HYDRANT FILL TUBE	1	112
1989	H GUTTER BROOM LIFT CYLINDER VALV	1	113
1989	H GUTTER BROOM LIFT CYLINDER VALV	1	113
1989	PICKUP HEAD LIFT	1	113
1990	FLOAT VALVE	3	113
1992	TAPPING PLATE	1	113
2000	RELIEF VALVE	1	113
2001	HOPPER LIFT CYLINDER VALVE	1	113
2001	PICKUP HEAD TILT	1	113
2005	DUMP VALVE	1	113
2005	LH GB MOTOR	1	113
2006	MANIFOLD	1	113
2005	RH GB MOTOR	1	113
2006	MANIFOLD	1	114
1411	HYD. FILTER BASE	1	114
1416	HYD. FILTER	1	114
9020	SUCTION SCREEN	1	114
3203	AUXILIARY HYD. PUMP	1	114
2074	HYD. PUMP	1	114
2219	INLINE CHECK VALVE	1	114
2221	INLINE CHECK VALVE	1	114
1068	FLOAT VALVE	1	114

PT #	DESCRIPTION	QTY	PG #
2222	SEQUENCE VALVE	1	114
3243	GB MOTOR	2	114
1955	HYD. OIL COOLER	1	114
9329	HOSE (COOLER TO TANK)	1	114
9328	HOSE (MANIFOLD TO COOLER)	1	114
9330	HOSE (TANK TO AUX HYD PUMP)	1	114
9331	HOSE (AUX HYD PUMP TO MANIFOLD)	1	114
9326	HOSE (TANK TO PUMP)	1	114
9327	HOSE (PUMP TO MANIFOLD)	1	114
9313	HOSE (MANIFOLD TO DUMP VALVE)	1	114
9314	HOSE (MANIFOLD TO SEQUENCE VALV)	1	114
9320	HOSE (MANIFOLD TO RH GB CYL)	3	114
9319	HOSE (MANIFOLD TO RH GB CYL)	1	114
1428	HOSE (GB CYL TO RETRACT CYL)	4	114
9323	HOSE (MANIFOLD TO LH GB CYL)	1	114
9322	HOSE (MANIFOLD TO LH GB CYL)	1	114
9315	HOSE (MANIFOLD TO PICKUP HEAD)	2	114
9316	HOSE (PICKUP HEAD TEE TO CYL)	4	114
9317	SE (MANIFOLD TO PICKUP HEAD TILT C	1	114
9318	HOSE (MANIFOLD TO GB MOTORS)	4	114
9339	HOSE (RH CASE DRAIN TO MANIFOLD)	1	114
9340	HOSE (LH CASE DRAIN TO MANIFOLD)	1	114
9312	HOSE (DUMP VALVE TO DUMP CYL)	2	114
9301	HOSE (DUMP VALVE TO DUMP CYL)	1	114
9300	HOSE (DUMP VALVE TO DUMP CYL)	3	114
9302	HOSE (TEE TO FLOOR BULKHEADS)	8	114
9303	HOSE (HOPPER INSIDE CORNER)	4	114
9304	HOSE (HOPPER INSIDE CORNER)	2	114
9305	HOSE (HOPPER INSIDE CORNER)	2	114
9308	HOSE (OUTSIDE DOOR CYL)	2	114
9309	HOSE (OUTSIDE DOOR CYL)	2	114
9306	HOSE (OUTSIDE LATCH CYL)	2	114
9307	HOSE (OUTSIDE LATCH CYL)	2	114
9332	HOSE (PSI GUAGE)	1	114
2082	PSI GUAGE	1	114
1411	HYD. FILTER BASE	1	116
1416	HYD. FILTER	1	116
1955	HYD. OIL COOLER	1	116
2030	RESTRICTOR	1	116
3243	MOTOR	6	116
9020	SUCTION SCREEN	1	116
9164	1/2" NY ONE WAY CHECK VALVE	1	116
9165	3/4" NY ONE WAY CHECK VALVE	1	116
1062	SIGHT GAUGE	1	116
1411	FILLTER BASE	1	116
1416	FILTER	1	116

PT #	DESCRIPTION	QTY	PG #
2082	PRESSURE INDICATOR	1	116
3203	AUX HYD PUMP	1	116
9020	SUCTION STRAINER	1	116
9030	VALVE	1	116
9041	BRASS PLUG	1	116
9074	FLUID LEVEL SENSOR	1	116
9075	TEMPERATURE SWITCH	1	116
9080	CONNECTOR	1	116
9098	HYDRAULIC TANK BREATHER	1	116
15002	HYD RESERVOIR	1	116
15003	INSPECTION COVER	1	116
9000	FAN SEAL	1	118
9034	BUSHING	1	118
15011	PORT COVER	1	118
15012	R4 FAN HOUSING 30IN	1	118
15013	BACKPLATE WELDMENT	1	118
15014	30" FAN S-SERIES	1	118
80190	LINER KIT FAN HOUSING	1	118
9004	WASH SPRING LOCK	40	119
9005	HEX NUT	40	119
9007	ELEVATOR BOLT	40	119
15019	RUBBER LINER	1	119
1916	BEACON	1	120
1968	CAMERA CABLE	2	120
1969	CAMERA/MONITOR	1	120
1970	CAMERA	2	120
9067	RUBBER BUMPER	2	120
15200	HINGE, ALUMINUM BLACK	8	120
15201	RUBBER HINGE SEPARATOR DOOR	1	120
15203	AIR VANE SEPARATOR	1	120
15204	SEPARATOR DOOR HOPPER	1	120
15205	HOPPER INTAKE TUBE	1	120
15206	REAR SEPARATOR COVER	1	120
15220	HOPPER FRAME WELDMENT	1	120
15221	SCREEN FRAME WELDMENT	2	120
15222	DUMP DOOR HINGE BRACKET	2	120
15223	STRIKER LATCH REAR DOOR	2	120
15224	HINGE PIN	2	120
15225	CONNECTOR ARM	2	120
15243	FRONT HOPPER SEPARATOR BRACE	1	120
15244	ACCESS COVER PLATE HOPPER	3	120
15245	DUMP DOOR CYLINDER	2	120
15258	ACCESS COVER	2	120
15260	RH DUMP DOOR CYL MOUNT	1	120
15265	LH DUMP DOOR CYL MOUNT	2	120
15817	LIMB GUARD	1	120

PT #	DESCRIPTION	QTY	PG #
80193	HOPPER ASSEMBLY	1	120
80194	HOPPER INSPECTION DOOR	2	120
80195	HOPPER TOP DOOR	1	120
80196	DUMP DOOR	1	120
15200	HINGE, ALUMINUM BLACK	8	121
80197	REAR LIGHT BAR	1	122
15207	LOWER BASIN SEPARATOR	1	122
15208	RH SEPARATOR WRAP	1	122
15209	LH SEPARATOR WRAP	1	122
15210	UPPER SIDE BRACE	2	122
15211	LH UPPER HOPPER SIDE	1	122
15212	RH UPPER HOPPER SIDE	1	122
15213	LH LOWER HOPPER SIDE	1	122
15214	RH LOWER HOPPER SIDE	1	122
15215	FRONT HOPPER	1	122
15216	HOPPER FLOOR	1	122
15217	LH DUMP GUSSET	1	122
15218	RH DUMP GUSSET	1	122
15219	BOLT PLATE REAR HOPPER	1	122
15247	REAR HOPPER	1	122
15248	SCROLL HOPPER SEPARATOR	1	122
15249	UPPER SEAL REAR BULKHEAD	1	122
15258	A ACCESS COVER DUMP GUSSET	2	122
9037	HAIR PIN COTTER	2	124
15227	HINGE	2	124
15250	TOP DOOR SKIN	1	124
15251	TOP DOOR BRACE	5	124
15255	LIFTING ROD	1	124
9072-202	SEAL	1	124
9081	SS SHROUD LATCH	1	125
15226	HOPPER INSPECTION DOOR	1	125
9072-68	INSPECTION DOOR D SEAL 68"	1	125
1393	2" STRANER	1	126
9110	HYD CYL 1-1/2 X 4	1	126
15228	DUMP DOOR HINGE	2	126
15229	LH LATCH CAM	1	126
15230	RH CAM LATCH	1	126
15231	LATCH CYLINDER MOUNTING BRACKET	2	126
15233	CONNECTING BAR HINGE PLATE	4	126
15234	LATCH ROD	2	126
15235	RETAINER PLATE LATCH ROD	2	126
15236	CYLINDER PIN ROD	2	126
15237	SUPPORT PLATE	2	126
15238	COVER PLATE (W/O HAND HOSE)	1	126
15240	LATCH ROD COUPLING	1	126
15241	DOOR CYLINDER ROD COUPLING	1	126

PT #	DESCRIPTION	QTY	PG #
15252	HOPPER DUMP DOOR PANEL	1	126
15253	INNER VERTICAL BRACE	5	126
15256	HOSE RACK	1	126
15257	DRAIN HOLE COVER	1	126
15710	HAND HOSE DEFLECTOR	1	126
15804	DOOR PROXIMITY MOUNT	1	126
15805	PROX MOUNT LATCH	1	126
15805	LATCH PROXIMITY MOUNT	1	126
1087-3	PROXIMITY SWITCH	2	126
9114-242	RECTANGLE SEAL	1	126
1028	CLEARANCE LIGHT (LED)	5	128
1131	GROMMET	5	128
9052	OVAL LIGHT GROMMET	4	128
9115	OVAL AMBER STROBE LIGHT	4	128
12518	TOP MARKER HARNESS	1	128
15242	LIGHT BAR REAR HOPPER	1	128
15400	FRONT FLAP	1	129
15401	MIDDLE FLAP	1	129
15402	REAR FLAP	2	129
15403	BLAST ORIFICE FLAP	1	129
1045	EYE BOLT	4	130
6133	CLEVIS BOLT	2	130
9019	RUBBER BUMPER	2	130
9073	EXTENSION SPRING	2	130
9089	CLAMP	2	130
9109	EXTENSION SPRING	2	130
9123	INTAKE TUBE STD	1	130
9134	HOSE CLAMP	2	130
9135	INTAKE TUBE HEV	1	130
15400	FRONT FLAP	1	130
15401	MIDDLE FLAP	1	130
15402	REAR FLAP	3	130
15403	BLAST ORIFICE FLAP	1	130
15404	HEAD CHANNEL	1	130
15405	DRAG SHOE	2	130
15406	HEAD INTAKE EXTENSION	1	130
15407	DEFLECTOR FLAP WELDMENT	1	130
15408	DEFLECTOR FLAP BACKING STRIP	1	130
15409	DEFLECTOR FLAP	1	130
15412	HEAD MOUNTING BRACKET	1	130
15413	CYLINDER	1	130
15414	CYLINDER	1	130
15415	BACKING STRIP	5	130
15417	LINK	2	130
15418	DRAG ARM	2	130
80211	HEAD FLAP KIT (ALL HEAD FLAPS)		130

PT #	DESCRIPTION	QTY	PG #
1137-07	CHAIN	4	130
1137-09	CHAIN	2	130
1137-26	CHAIN	1	130
1028	CLEARANCE LIGHT (LED)	2	132
1131	GROMMET	2	132
1908	LICENCE LAMP	2	132
1909	BACKUP	2	132
1910	TURN AMBER	4	132
1911	BACK-UP	2	132
1912	GROMMET	6	132
9029	LICENSE PLATE SCREW RECEPTACLE	2	132
12500	REAR BUMPER	1	132
12517	BUMPER WIRING HARNESS	1	132
15602	CROSSOVER TUBE	1	133
15603	REAR MOUNTING TUBE	1	133
15604	LH FRONT MOUNT	1	133
15605	RH FRONT MOUNT	1	133
80202	LH TOOLBOX ASSY	1	133
80204	RH TOOLBOX ASSY	1	133
1916	STROBE	1	133
1955	HYDRAULIC COOLER	1	133
9081	SHROUD LATCH	4	133
9095	GAS SPRING 58#	4	134
15300	SHROUD FRAME WELDMENT	1	134
15308	PIANO HINGE	6	134
42107	LIMB GUARD	1	134
80198	LH UPPER SHROUD DOOR	1	134
80199	LH LOWER SHROUD DOOR	1	134
80200	RH UPPER SHROUD DOOR	1	134
80201	RH LOWER SHROUD DOOR	1	134
1018	SUSPENSION SPRING	2	136
1019	RETRACT SPRING	1	136
1020	BUSHING	4	136
1022	TURN BUCKLE	2	136
1023	TURN BUCKLE	1	136
1042	QUICK LINK	4	136
1185	BUSHING	4	136
1379	CYLINDER	2	136
1503	NUT	2	136
1505	NUT	1	136
1506	NUT	5	136
1507	NUT	7	136
1508	NUT	1	136
1526	WASHER	2	136
1537	BOLT	3	136
1540	BOLT	2	136

PT #	DESCRIPTION	QTY	PG #
1556	BOLT	2	136
1559	BOLT	5	136
1560	BOLT	2	136
1561	BOLT	1	136
1574	BOLT	1	136
1581	WASHER	1	136
1640	NUT	1	136
1642	NUT	2	136
1670	WASHER	3	136
1822	WASHERS	3	136
9137	LANYARD	2	136
41205	LINKAGE MOUNT (LEFT)	1	136
41211	PIN	2	136
41215	SPRING BELL CRANK	1	136
41221	LINK	1	136
41230	EXTEND SPRING MOUNT	1	136
41316	LINKAGE MOUNT (RIGHT)	1	136
61201	GB MOUNT (LEFT HAND)	1	136
61203	GB PIVOT (LEFT)	1	136
61213	PIN	1	136
61235	RETRACT PLATE (LEFT)	1	136
61301	GB MOUNT (RIGHT HAND)	1	136
61303	GB PIVOT (RIGHT)	1	136
61335	RETRACT PLATE (RIGHT)	1	136
43219	WARNING THIS VEHICLE IS EQUIPED	1	136
1078	LINEAR ACTUATOR	1	138
1148	GB BRUSH SET FOR 32" PLATE	1	138
1505	NUT	2	138
1506	NUT	4	138
1525	WASHER	2	138
1526	WASHER	1	138
1537	BOLT	3	138
1540	BOLT	24	138
1546	BOLT	2	138
1549	BOLT	4	138
1670	WASHER	5	138
1683	KEY	1	138
1822	WASHERS	1	138
3243	MOTOR	1	138
3248	BUSHING C/W 3-BOLT, 3-LW	1	138
41207	MOTOR BRACKET (LEFT)	1	138
41209	DRIVE HUB	1	138
41227	32" PLATE	1	138
41318	MOTOR BRACKET (RIGHT)	1	138
42316	WASHER	2	138
1076	12 VOLT 7 GPM WATER PUMP	1	140

PT #	DESCRIPTION	QTY	PG #
1116	HOSE	35'	140
1117	WATER FILTER HOUSING	1	140
1130	WATER TANK ELBOW	1	140
1158	HOSE BARB FITTING	4	140
1159	BALL VALVE	1	140
1160	NIPPLE	1	140
1163	HOSE BARB TEE ADAPTER	5	140
1166	HOSE	50'	140
1167	HOSE BARB FITTING	2	140
1168	U BOLT	8	140
1169	HOSE CLAMP	28	140
1172	WATER FILTER ELEMENT	1	140
1185	PLUG	1	140
1203	HOSE CLAMP	4	140
1204	BALL VALVE	4	140
2081	PRESSURE WASHER PUMP	1	140
2083	REEL	1	140
3232	WATER PUMP	3	140
9035	WATER PUMP	1	140
9216	ADAPTER/NOZZLE ASSY	12	140
9217	NOZZLE	12	140
15026	WATER PUMP DISTRIBUTION BAR	1	140
42201	SPRAY BAR	2	140
42205	SPRAY BAR HANGER	4	140
62216	GB SPRAY BAR	2	140
80223	WAND KIT	1	140
1090	OIL PRESSURE GAUGE	1	142
1091	WATER TEMP GAUGE	1	142
1092	TACH/HOUR METER	1	142
1094	SHUT DOWN MODULE	1	142
1095	IGNITION SWITCH	1	142
42527	ENGINE CONTROL	1	142
1101	SHOCK MOUNT	4	144
1684	SWITCH (S-O-S)	6	144
1685	SWITCH (S-O-M)	3	144
1686	SWITCH (M-O-M)	5	144
1689	HOLE PLUG	2	144
1691	LED	2	144
1769	CAMERA MONITOR SYS	1	144
1796	MAP LIGHT	1	144
1947	RELAYS (NOT SHOWN)	7	144
1968	GREEN SWITCH COVERS	1	144
1969	RED SWITCH COVERS	14	144
1971	PCB	1	144
12510	PANEL	1	144
12511	PANEL DECAL	1	144
12515	HARNES	1	144
62505	BOX	1	144
62511	SWITCH BOX HARNES	1	144
80209	SWEEPER CONTROL	1	144
1194	PEDISTAL KNOB	2	146
1233	ELECT. BOOT	1	146

PT #	DESCRIPTION	QTY	PG #
1501	NUT	7	146
1505	NUT	1	146
1520	WASHER	4	146
1531	BOLT	7	146
1546	BOLT	1	146
42501	ADAPTER PLATE	1	146
42502	SUPPORT POST	1	146
42503	TOP MOUNT	1	146
42506	BOX MOUNT PLATE	1	146
42510	OFFSET POST	1	146
1193	FUSE 5 amp F6	2	147
1946	RELAY	1	147
1947	RELAY	1	147
2041	FUSE HOLDER 8 POSITION	7	147
2042	FUSE 15 amp F1-5/7/8	1	147
2043	CIRCUIT BREAKER	1	147
12512	Harness (not shown)	1	147
62507	Aux. Box Mounting Plate	1	147
80207	AUXILIARY CONTROL BOX	6	147
12512	AUXILIARY CONTROL	1	148
12514	VALVE HARNES	1	149
12513	BODY HARNES	1	150
12515	SWITCH BOX HARNES	1	151
12517	BUMPER HARNES	1	152
12518	TOP MARKER HARNES	1	153
12519	TOP BEACON HARNES	1	154
9058	CHAIN LINK	2	156
9059	3/16 CHAIN	1	156
9072	RUBBER SEAL	1	156
9082	SHACKLE	4	156
9109	EXTENSION SPRING	1	156
9113	8" HAND HOSE SECTION	1	156
9116	PLASTIC HANDLE	2	156
9118	S-HOOK	3	156
9119	BUNGEE STRAP	3	156
9134	HOSE CLAMP	2	156
9263	AND CLAMP (2 NEEDED FOR EXTENSION)	2	156
9266	WAND EXTENSION (OPTIONAL)	1	156
9267	WAND TUBE	1	156
9268	HOSE CONNECTION FLANGE	1	156
9269	HOSE CLAMP	1	156
15700	MOUNTING BRACKET	1	156
15701	TRANSITION DOOR	1	156
15702	COVER DOOR	1	156
15703	LATCH HANDLE	2	156
15704	UPPER HINGE PLATE	1	156
15705	PIVOT BRACKET	1	156
15707	BRIDGE PLATE	1	156
15708	BOOM ARM REST	1	156
15709	HOSE BRACKET	3	156
15710	DEFLECTOR REAR DOOR	1	156
15711	RUBBER HANGER	2	156

INDEX BY PART#

PT #	DESCRIPTION	QTY	PG #
1018	SUSPENSION SPRING	2	136
1019	RETRACT SPRING	1	136
1020	BUSHING	4	136
1022	TURN BUCKLE	2	136
1023	TURN BUCKLE	1	136
1028	CLEARANCE LIGHT (LED)	5	128
1028	CLEARANCE LIGHT (LED)	2	132
1042	QUICK LINK	4	136
1045	EYE BOLT	4	130
1062	SIGHT GAUGE	1	116
1068	FLOAT VALVE	1	114
1076	12 VOLT 7 GPM WATER PUMP	1	140
1078	LINEAR ACTUATOR	1	138
1087-3	PROXIMITY SWITCH	2	126
1090	OIL PRESSURE GAUGE	1	142
1091	WATER TEMP GAUGE	1	142
1092	TACH/HOUR METER	1	142
1094	SHUT DOWN MODULE	1	142
1095	IGNITION SWITCH	1	142
1101	SHOCK MOUNT	4	144
1116	HOSE	35'	140
1117	WATER FILTER HOUSING	1	140
1130	WATER TANK ELBOW	1	140
1131	GROMMET	5	128
1131	GROMMET	2	132
1137-07	CHAIN	4	130
1137-09	CHAIN	2	130
1137-26	CHAIN	1	130
1148	GB BRUSH SET FOR 32" PLATE	1	138
1158	HOSE BARB FITTING	4	140
1159	BALL VALVE	1	140
1160	NIPPLE	1	140
1163	HOSE BARB TEE ADAPTER	5	140
1166	HOSE	50'	140
1167	HOSE BARB FITTING	2	140
1168	U BOLT	8	140
1169	HOSE CLAMP	28	140
1172	WATER FILTER ELEMENT	1	140
1185	BUSHING	4	136
1185	PLUG	1	140
1193	FUSE 5 amp F6	2	147
1194	PEDISTAL KNOB	2	146
1203	HOSE CLAMP	4	140
1204	BALL VALVE	4	140
1233	ELECT. BOOT	1	146
1299	THROTTLE GUIDE	1	110
1379	CYLINDER	2	136
1387	THROTTLE ACTUATOR	1	110
1388	THROTTLE ACTUATOR CABLE	1	110
1393	2" STRAINER	1	126
1411	HYD. FILTER BASE	1	114
1411	HYD. FILTER BASE	1	116

PT #	DESCRIPTION	QTY	PG #
1411	FILLTER BASE	1	116
1416	HYD. FILTER	1	114
1416	HYD. FILTER	1	116
1416	FILTER	1	116
1428	HOSE (GB CYL TO RETRACT CYL)	4	114
1501	NUT	7	146
1503	NUT	2	136
1505	NUT	1	136
1505	NUT	2	138
1505	NUT	1	146
1506	NUT	5	136
1506	NUT	4	138
1507	NUT	7	136
1508	NUT	1	136
1520	WASHER	4	146
1525	WASHER	2	138
1526	WASHER	2	136
1526	WASHER	1	138
1531	BOLT	7	146
1537	BOLT	3	136
1537	BOLT	3	138
1540	BOLT	2	136
1540	BOLT	24	138
1546	BOLT	2	138
1546	BOLT	1	146
1549	BOLT	4	138
1556	BOLT	2	136
1559	BOLT	5	136
1560	BOLT	2	136
1561	BOLT	1	136
1574	BOLT	1	136
1581	WASHER	1	136
1640	NUT	1	136
1642	NUT	2	136
1670	WASHER	3	136
1670	WASHER	5	138
1683	KEY	1	138
1684	SWITCH (S-O-S)	6	144
1685	SWITCH (S-O-M)	3	144
1686	SWITCH (M-O-M)	5	144
1689	HOLE PLUG	2	144
1691	LED	2	144
1769	CAMERA MONITOR SYS	1	144
1796	MAP LIGHT	1	144
1822	WASHERS	3	136
1822	WASHERS	1	138
1908	LICENCE LAMP	2	132
1909	BACKUP	2	132
1910	TURN AMBER	4	132
1911	BACK-UP	2	132
1912	GROMMET	6	132
1916	BEACON	1	120

1916	STROBE	1	133
1946	RELAY	1	147
1947	RELAYS (NOT SHOWN)	7	144
1947	RELAY	1	147
1955	HYD. OIL COOLER	1	114
1955	HYD. OIL COOLER	1	116
1955	HYDRAULIC COOLER	1	133
1968	CAMERA CABLE	2	120
1968	GREEN SWITCH COVERS	1	144
1969	CAMERA/MONITOR	1	120
1969	RED SWITCH COVERS	14	144
1970	CAMERA	2	120
1971	PCB	1	144
1989	H GUTTER BROOM LIFT CYLINDER VALV	1	113
1989	H GUTTER BROOM LIFT CYLINDER VALV	1	113
1989	PICKUP HEAD LIFT	1	113
1990	FLOAT VALVE	3	113
1992	TAPPING PLATE	1	113
2000	RELIEF VALVE	1	113
2001	HOPPER LIFT CYLINDER VALVE	1	113
2001	PICKUP HEAD TILT	1	113
2005	DUMP VALVE	1	113
2005	LH GB MOTOR	1	113
2005	RH GB MOTOR	1	113
2006	MANIFOLD	1	113
2006	MANIFOLD	1	114
2030	RESTRICTOR	1	116
2041	FUSE HOLDER 8 POSITION	7	147
2042	FUSE 15 amp F1-5/7/8	1	147
2043	CIRCUIT BREAKER	1	147
2071	ENGINE	1	110
2072	DRIVE	1	110
2073	COUPLING	1	110
2074	HYDRAULIC PUMP	1	110
2074	HYD. PUMP	1	114
2081	PRESSURE WASHER PUMP	1	140
2082	PSI GAUGE	1	114
2082	PRESSURE INDICATOR	1	116
2083	REEL	1	140
2219	INLINE CHECK VALVE	1	114
2221	INLINE CHECK VALVE	1	114
2222	SEQUENCE VALVE	1	114
2254	MUFFLER FLANGE	1	110
2257	ALTERNATOR (NOT SHOWN)	1	110
2258	STARTER (NOT SHOWN)	1	110
2259	FUEL FILTER (NOT SHOWN)	1	110
2260	SOLENOID (NOT SHOWN)	1	110
2262	AIR CLEANER	1	110
2264	COVER	1	110
2267	FILTER PRIMARY	1	110
2268	FILTER SECONDARY	1	110
2271	INLET HOOD	1	110
2272	MOUNTING BAND	1	110

2276	MUFFLER	1	110
2277	STACK CAP	1	110
2278	MUFFLER MOUNTING BAND	1	110
3203	AUXILIARY HYD. PUMP	1	114
3203	AUX HYD PUMP	1	116
3232	WATER PUMP	3	140
3243	GB MOTOR	2	114
3243	MOTOR	6	116
3243	MOTOR	1	138
3248	BUSHING C/W 3-BOLT, 3-LW	1	138
6133	CLEVIS BOLT	2	130
9000	FAN SEAL	1	118
9004	WASH SPRING LOCK	40	119
9005	HEX NUT	40	119
9007	ELEVATOR BOLT	40	119
9017	BEARING	1	110
9019	RUBBER BUMPER	2	130
9020	SUCTION SCREEN	1	114
9020	SUCTION SCREEN	1	116
9020	SUCTION STRAINER	1	116
9029	LICENSE PLATE SCREW RECEPTACLE	2	132
9030	VALVE	1	116
9031	BUSHING	2	110
9034	BUSHING	1	118
9035	WATER PUMP	1	140
9037	HAIR PIN COTTER	2	124
9041	BRASS PLUG	1	116
9052	OVAL LIGHT GROMMET	4	128
9058	CHAIN LINK	2	156
9059	3/16 CHAIN	1	156
9066	RUBBER EDGE TRIM 17"	4	106
9067	RUBBER BUMPER	2	120
9072	RUBBER SEAL	1	156
9072-202	SEAL	1	124
9072-68	INSPECTION DOOR D SEAL 68"	1	125
9073	EXTENSION SPRING	2	130
9074	FLUID LEVEL SENSOR	1	116
9075	TEMPERATURE SWITCH	1	116
9076	HOSE CLAMP (NOT SHOWN)	1	112
9080	CONNECTOR	1	116
9081	SS SHROUD LATCH	1	125
9081	SHROUD LATCH	4	133
9082	SHACKLE	4	156
9084	CLAMPING U-BOLT	2	112
9086	PULLEY	1	110
9087	PULLEY	1	110
9089	CLAMP	2	130
9094	BELT	1	110
9095	GAS SPRING 58#	4	134
9096	VIBRATION ISOLATOR	6	110
9098	HYDRAULIC TANK BREATHER	1	116
9102	FIRE HOSE (NOT SHOWN)	1	112
9103	KING NIPPLE (NOT SHOWN)	1	112

PT #	DESCRIPTION	QTY	PG #
9104	WASS HYDRANT COUPLING (NOT SHOW	1	112
9105	QUICK DISCONNECT	1	112
9106	QUICK DISCONNECT (NOT SHOWN)	1	112
9107	ALUMINUM DUST CAP (NOT SHOWN)	1	112
9108	FAN SHAFT	1	110
9109	EXTENSION SPRING	2	130
9109	EXTENSION SPRING	1	156
9110	HYD CYL 1-1/2 X 4	1	126
9113	8" HAND HOSE SECTION	1	156
9114-242	RECTANGLE SEAL	1	126
9115	OVAL AMBER STROBE LIGHT	4	128
9116	PLASTIC HANDLE	2	156
9118	S-HOOK	3	156
9119	BUNGEE STRAP	3	156
9122	DUMP CYLINDER	2	106
9123	INTAKE TUBE STD	1	130
9129	INTAKE TRANSITION SEAL	1	106
9134	HOSE CLAMP	2	130
9134	HOSE CLAMP	2	156
9135	INTAKE TUBE HEV	1	130
9137	LANYARD	2	136
9164	1/2" NY ONE WAY CHECK VALVE	1	116
9165	3/4" NY ONE WAY CHECK VALVE	1	116
9169	BLEEDER DOOR CABLE	1	108
9216	ADAPTER/NOZZLE ASSY	12	140
9217	NOZZLE	12	140
9263	WAND CLAMP (2 NEEDED FOR EXTENSION)	2	156
9266	WAND EXTENSION (OPTIONAL)	1	156
9267	WAND TUBE	1	156
9268	HOSE CONNECTION FLANGE	1	156
9269	HOSE CLAMP	1	156
9300	HOSE (DUMP VALVE TO DUMP CYL)	3	114
9301	HOSE (DUMP VALVE TO DUMP CYL)	1	114
9302	HOSE (TEE TO FLOOR BULKHEADS)	8	114
9303	HOSE (HOPPER INSIDE CORNER)	4	114
9304	HOSE (HOPPER INSIDE CORNER)	2	114
9305	HOSE (HOPPER INSIDE CORNER)	2	114
9306	HOSE (OUTSIDE LATCH CYL)	2	114
9307	HOSE (OUTSIDE LATCH CYL)	2	114
9308	HOSE (OUTSIDE DOOR CYL)	2	114
9309	HOSE (OUTSIDE DOOR CYL)	2	114
9312	HOSE (DUMP VALVE TO DUMP CYL)	2	114
9313	HOSE (MANIFOLD TO DUMP VALVE	1	114
9314	HOSE (MANIFOLD TO SEQUENCE VALV	1	114
9315	HOSE (MANIFOLD TO PICKUP HEAD)	2	114
9316	HOSE (PICKUP HEAD TEE TO CYL)	4	114
9317	HOSE (MANIFOLD TO PICKUP HEAD TILT C	1	114
9318	HOSE (MANIFOLD TO GB MOTORS)	4	114
9319	HOSE (MANIFOLD TO RH GB CYL)	1	114
9320	HOSE (MANIFOLD TO RH GB CYL)	3	114
9322	HOSE (MANIFOLD TO LH GB CYL)	1	114
9323	HOSE (MANIFOLD TO LH GB CYL)	1	114
9326	HOSE (TANK TO PUMP)	1	114

PT #	DESCRIPTION	QTY	PG #
9327	HOSE (PUMP TO MANIFOLD)	1	114
9328	HOSE (MANIFOLD TO COOLER)	1	114
9329	HOSE (COOLER TO TANK)	1	114
9330	HOSE (TANK TO AUX HYD PUMP)	1	114
9331	HOSE (AUX HYD PUMP TO MANIFOLD)	1	114
9332	HOSE (PSI GAUGE)	1	114
9339	HOSE (RH CASE DRAIN TO MANIFOLD)	1	114
9340	HOSE (LH CASE DRAIN TO MANIFOLD)	1	114
12500	REAR BUMPER	1	132
12510	PANEL	1	144
12511	PANEL DECAL	1	144
12512	Harness (not shown)	1	147
12512	AUXILIARY CONTROL	1	148
12513	BODY HARNESS	1	150
12514	VALVE HARNESS	1	149
12515	HARNESS	1	144
12515	SWITCH BOX HARNESS	1	151
12517	BUMPER WIRING HARNESS	1	132
12517	BUMPER HARNESS	1	152
12518	TOP MARKER HARNESS	1	128
12518	TOP MARKER HARNESS	1	153
12519	TOP BEACON HARNESS	1	154
15000	R-6 MOUNTING PLATE PM	2	108
15001	R-6 POWER MODULE WELDMENT	1	108
15002	HYD RESERVOIR	1	116
15003	INSPECTION COVER	1	116
15004	WATER RESERVOIR 200 GAL	1	108
15005	HYDRANT FILL TUBE WELDMENT	1	108
15005	HYDRANT FILL TUBE	1	112
15006	SLIDE BAR ENGINE SKID	2	110
15007	ENGINE SKID	1	110
15008	BELT GUARD	1	110
15009	HEAD WASHER	6	110
15010	TAIL WASHER	6	110
15011	PORT COVER	1	118
15012	R4 FAN HOUSING 30IN	1	118
15013	BACKPLATE WELDMENT	1	118
15014	30" FAN S-SERIES	1	118
15015	FUEL FILLER BRACKET	1	108
15019	RUBBER LINER	1	119
15021	THROTTLE ARM	1	110
15026	WATER PUMP DISTRIBUTION BAR	1	140
15100	BOLT PLATE TRANSITION	1	106
15101	MAIN FRAME WELDMENT	1	106
15102	REAR BUMPER MOUNTING BRACKET	1	106
15103	TRANSITION MOUNTING BRACKET	1	106
15104	MIDDLE TIE DOWN MAIN FRAME	2	106
15105	HEAD SPRING HANGER	2	106
15106	HEAD SPRING HANGER	4	106
15107	R-6 DRAG ARM BRACKET	2	106
15108	4 INTAKE TRANSITION TUBE WELDMENT	1	106
15109	HINGE BOLT ASSY R-6 MAIN FRAME	2	106
15110	SAFETY CHAULK HOPPER DUMP	2	106

PT #	DESCRIPTION	QTY	PG #
15200	HINGE, ALUMINUM BLACK	8	121
15200	HINGE, ALUMINUM BLACK	8	120
15201	RUBBER HINGE SEPARATOR DOOR	1	120
15203	AIR VANE SEPARATOR	1	120
15204	SEPARATOR DOOR HOPPER	1	120
15205	HOPPER INTAKE TUBE	1	120
15206	REAR SEPARATOR COVER	1	120
15207	LOWER BASIN SEPARATOR	1	122
15208	RH SEPARATOR WRAP	1	122
15209	LH SEPARATOR WRAP	1	122
15210	UPPER SIDE BRACE	2	122
15211	LH UPPER HOPPER SIDE	1	122
15212	RH UPPER HOPPER SIDE	1	122
15213	LH LOWER HOPPER SIDE	1	122
15214	RH LOWER HOPPER SIDE	1	122
15215	FRONT HOPPER	1	122
15216	HOPPER FLOOR	1	122
15217	LH DUMP GUSSET	1	122
15218	RH DUMP GUSSET	1	122
15219	BOLT PLATE REAR HOPPER	1	122
15220	HOPPER FRAME WELDMENT	1	120
15221	SCREEN FRAME WELDMENT	2	120
15222	DUMP DOOR HINGE BRACKET	2	120
15223	STRIKER LATCH REAR DOOR	2	120
15224	HINGE PIN	2	120
15225	CONNECTOR ARM	2	120
15226	HOPPER INSPECTION DOOR	1	125
15227	HINGE	2	124
15228	DUMP DOOR HINGE	2	126
15229	LH LATCH CAM	1	126
15230	RH CAM LATCH	1	126
15231	LATCH CYLINDER MOUNTING BRACKET	2	126
15233	CONNECTING BAR HINGE PLATE	4	126
15234	LATCH ROD	2	126
15235	RETAINER PLATE LATCH ROD	2	126
15236	CYLINDER PIN ROD	2	126
15237	SUPPORT PLATE	2	126
15238	COVER PLATE (W/O HAND HOSE)	1	126
15240	LATCH ROD COUPLING	1	126
15241	DOOR CYLINDER ROD COUPLING	1	126
15242	LIGHT BAR REAR HOPPER	1	128
15243	FRONT HOPPER SEPARATOR BRACE	1	120
15244	ACCESS COVER PLATE HOPPER	3	120
15245	DUMP DOOR CYLINDER	2	120
15247	REAR HOPPER	1	122
15248	SCROLL HOPPER SEPARATOR	1	122
15249	UPPER SEAL REAR BULKHEAD	1	122
15250	TOP DOOR SKIN	1	124
15251	TOP DOOR BRACE	5	124
15252	HOPPER DUMP DOOR PANEL	1	126
15253	INNER VERTICAL BRACE	5	126
15255	LIFTING ROD	1	124
15256	HOSE RACK	1	126

PT #	DESCRIPTION	QTY	PG #
15257	DRAIN HOLE COVER	1	126
15258	ACCESS COVER	2	120
15258	ACCESS COVER DUMP GUSSET	2	122
15260	RH DUMP DOOR CYL MOUNT	1	120
15265	LH DUMP DOOR CYL MOUNT	2	120
15300	SHROUD FRAME WELDMENT	1	134
15308	PIANO HINGE	6	134
15400	FRONT FLAP	1	129
15400	FRONT FLAP	1	130
15401	MIDDLE FLAP	1	129
15401	MIDDLE FLAP	1	130
15402	REAR FLAP	2	129
15402	REAR FLAP	3	130
15403	BLAST ORIFICE FLAP	1	129
15403	BLAST ORIFICE FLAP	1	130
15404	HEAD CHANNEL	1	130
15405	DRAG SHOE	2	130
15406	HEAD INTAKE EXTENSION	1	130
15407	DEFLECTOR FLAP WELDMENT	1	130
15408	DEFLECTOR FLAP BACKING STRIP	1	130
15409	DEFLECTOR FLAP	1	130
15412	HEAD MOUNTING BRACKET	1	130
15413	CYLINDER	1	130
15414	CYLINDER	1	130
15415	BACKING STRIP	5	130
15417	LINK	2	130
15418	DRAG ARM	2	130
15602	CROSSOVER TUBE	1	133
15603	REAR MOUNTING TUBE	1	133
15604	LH FRONT MOUNT	1	133
15605	RH FRONT MOUNT	1	133
15700	MOUNTING BRACKET	1	156
15701	TRANSITION DOOR	1	156
15702	COVER DOOR	1	156
15703	LATCH HANDLE	2	156
15704	UPPER HINGE PLATE	1	156
15705	PIVOT BRACKET	1	156
15707	BRIDGE PLATE	1	156
15708	BOOM ARM REST	1	156
15709	HOSE BRACKET	3	156
15710	HAND HOSE DEFLECTOR	1	126
15710	DEFLECTOR REAR DOOR	1	156
15711	RUBBER HANGER	2	156
15714	SPRING BOOM ARM	1	156
15801	PUMP MOUNT	1	110
15804	DOOR PROXIMITY MOUNT	1	126
15805	PROX MOUNT LATCH	1	126
15805	LATCH PROXIMITY MOUNT	1	126
15817	LIMB GUARD	1	120
41205	LINKAGE MOUNT (LEFT)	1	136
41207	MOTOR BRACKET (LEFT)	1	138
41209	DRIVE HUB	1	138
41211	PIN	2	136

