

★ STARFIRE S-4c



An Effectively Simple, Full-Featured, Heavy Duty 4 yd³ Broom Sweeper Mounted on a Highly-Maneuverable, Non-CDL Chassis



Proudly
American 

STEWART-AMOS
Sweeper Co.

★ STARFIRE S-4c

- ▶ **Highly Productive Performance**
- ▶ **Rugged and Reliable**
- ▶ **Extremely Maneuverable**

The **S-4c** is a heavy duty, full-featured 4 yd³ dual engine mechanical broom street sweeper that is mounted on a highly-maneuverable cab-over chassis. It's as productive as sweepers mounted on larger chassis yet does not require a CDL to operate. Manufactured with reliability and durability in mind, the **S-4c** is capable of traveling from jobsite to jobsite at highway speeds. Its compact design makes this sweeper the perfect choice for cleaning confined city streets, cul-de-sacs, construction sites, and milling jobs.

The environmentally conscious **S-4c** is SCAQMD PM-10 Rule 1186 [Certified](#).

At Stewart-Amos, we build every sweeper to the highest quality standards that incorporate our *effectively simple* design criteria. With ease of operation, service and maintenance in mind, we engineer and select each component and system to be rugged, reliable and uncomplicated while providing for the most effective and highest sweeping performance.

We look forward to building one for you. Please contact your local dealer for more information or to arrange a demonstration.

The Stewart-Amos Exclusive 3-Shaft Elevator

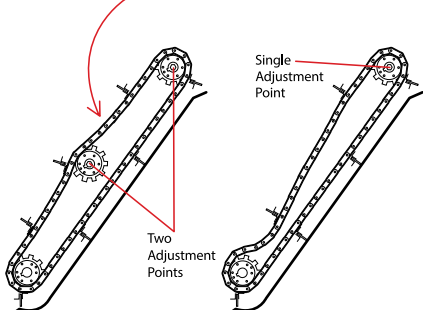

The diagram shows two side-by-side views of an elevator mechanism. The left view is labeled 'Two Adjustment Points' and shows a chain drive with two gears. The right view is labeled 'Single Adjustment Point' and shows a chain drive with three gears. A red arrow points from the text to the 3-shaft diagram.

7 Extended Chain Life. 3rd shaft provides proper return (upper) chain support. This allows chains to run as loose as possible dramatically improving chain wear life versus similar 2-shaft designs.

Reduced Maintenance Costs. 3rd shaft provides twice the number of chain adjustment points. Together with reduced chain wear, this significantly reduces maintenance downtime & costs versus 2-shaft designs.

Better Loading/Sweeping Performance. Eliminates chain clapping common in 2-shaft designs. 3rd shaft optimizes chain spacing, reduces clogging & ensures more effective sweeping of large, bulky debris.

S-4c Standard Performance, Productivity & Safety Features:

- 1** 200 gallon polyethylene water tank with 3.6 gpm diaphragm pump & elevator wash-down system come standard. Spray nozzles: 2 per curb broom, 4 on main broom & 4 on front spray bar.
- 2** One-piece all steel main frame consists of HD tube, C-channel, and thick plates. This structure allows for rugged & reliable durability.
- 3** Elevator auto pivots up to 10" over fixed obstructions preventing impact damage. No operator judgment required.
- 4** Cast iron gear pump is more tolerant of heat and contaminants, making it simple & economical to troubleshoot, repair or replace.
- 5** 59 HP Kubota turbo-charged diesel engine with high temperature/ low oil pressure auto shutdown. This engine is quiet & fuel efficient.
- 6** *Effectively simple* electric-over hydraulic system with built-in hydraulic pressure gauges for ease of service.
- 8** Electric-powered, continuous-running hydraulic oil cooler is roof-mounted to prevent clogging & provide maximum cooling.
- 9** Color camera system keeps operator facing forward. Sweeper comes standard with dashboard-mounted 7" color monitor with right gutter broom & rear backup cameras. Optional hopper dump observation & hopper inside loading view cameras are available.
- 10** Mounted on a 19,500# GVWR cab-over chassis with short 109" wheelbase. This unit offers extremely tight (16'9") turning radius & excellent forward visibility. Optional air ride suspension is available.
- 11** Larger 36-gallon fuel tank allows for longer run time & increased productivity.
- 12** Front & rear lockable canopies protect components from passing branches, elements & vandalism. Canopies prevent algae growth in the water tank which can clog spray nozzles.

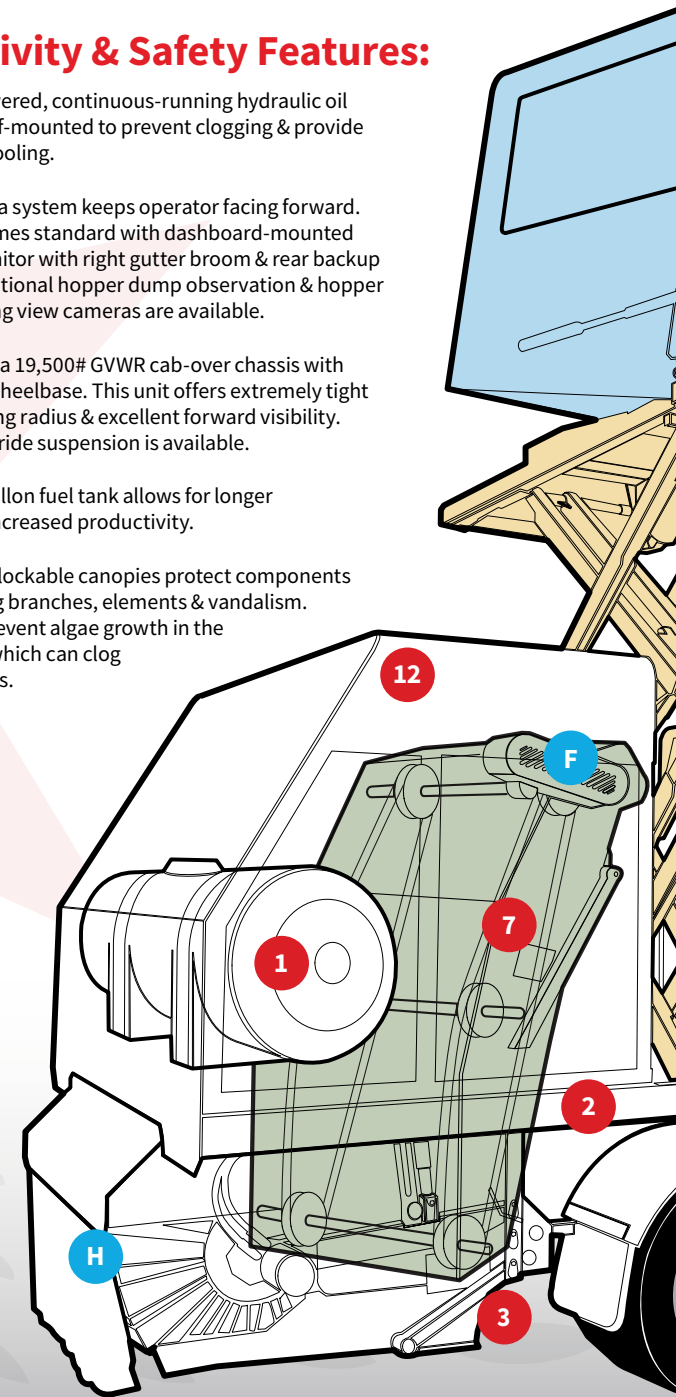

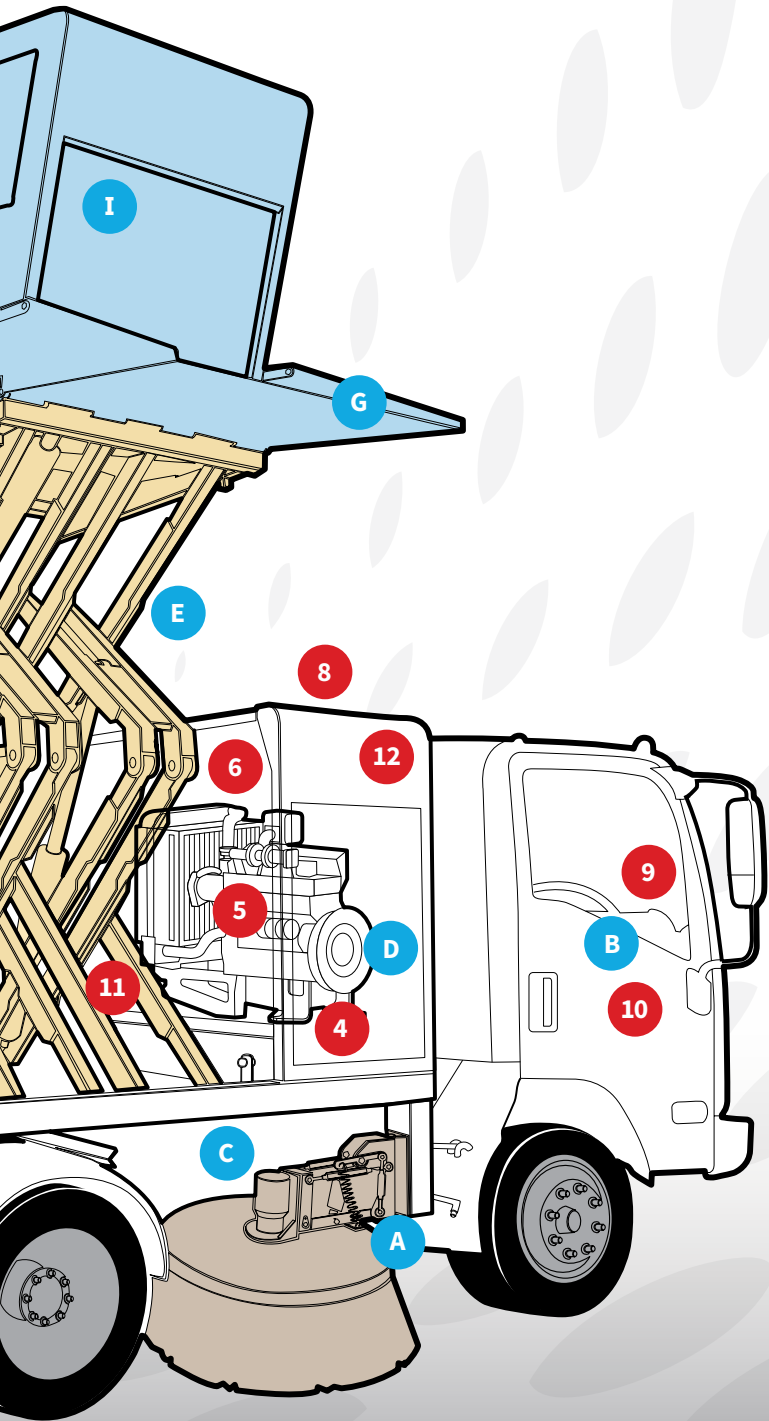

A Spring-Balanced Brooms



Spring-balanced, free-floating main & gutter brooms automatically apply correct surface pressure for maximum broom wear life. In-cab gutter broom electric tilt is standard.

B Ergonomic Controls



Vertically-mounted control panel is 6-way adjustable for easy & ergonomic viewing. One-touch sweeping allows operator to preset functions. Brooms raise automatically in reverse.

C Case Drains



Case drains on all the hydraulic motors protect shaft seals from pressure leaks minimizing repairs & replacements.

D Simplified Wiring



Electrical relays & fuses are protected from the elements in a sealed NEMA 4 enclosure. The wiring is heat stamped with numbers for easy identification.

E Massive Lift Scissors



Massive "X" style lift scissors & 4-corner hopper lift ensure exceptional hopper stability when dumping wet, unbalanced, or sticky debris.

F Off-set Drive Motor



Off-set hydraulic elevator drive motor is protected against impacts.

G High Dump Hopper



Variable dump height hopper (up to 11' high) with 44" extra-long dump door easily reaches most dump trucks.

H Main Broom Channeler



Main broom channeler (optional) effectively sweeps large quantities of bulky & light debris (leaves/pine straw). Self-adjusting as main broom wears.

I Left or Right Side Dump



Left (street) or Right (curb) side dump available depending on which side best matches your visibility, safety & productivity needs. Dump side must be chosen at time of purchase.

S-4c SPECIFICATIONS

General:

Sweeping Path: 10' maximum
Debris Hopper: 4.0 cubic yards volumetric
Dump Height (variable): 16" to 132"
Turning Radius: 16' 9"
Overall Length: 19' 5"
Overall Height: 102.5" including strobe lights
GWR: 19,500#

Main Broom:

Length: 58" Diameter: 36"
Type: Chevron poly-wire combo
Drive: Hydraulic motor/direct drive & reversible
Mounting: Full-floating, trailing arm, with shocks
Lift Control: Hydraulic, in-cab
Speed: Variable with auxiliary engine rpm
Dirt Shoes: Carbide, 2" wide

Dual Gutter Brooms:

Diameter: 42"
Type: Spring-balanced, auto wear compensating
Drive: Hydraulic & reversible
Mounting: Free-floating, trailing arm
Lift Control: Hydraulic, in-cab
Tilt control: In-cab (electric)
Speed: Variable with auxiliary engine rpm
Dual Float Protected

Elevator System:

Type: 7-flight squeegee with replaceable rubber edging
Liner: Bolt-in, 2 piece AR steel plates
Chain: HD constant radius roller chain
Sprockets: Urethane
Shafts: Three
Drive: Hydraulic, in-cab, & reversible
Lift Control: Hydraulic, in-cab
Elevator Jam Warning: Buzzer & light in-cab
Flushing System: Built-in

Debris Hopper:

Volumetric Capacity: 4.0 cubic yards
Dump Height (variable): 16" to 132"
Hopper Door Reach from Side: 44"
Inspection door, window, & safety props standard
4 Corner hopper lift
Quad (4) "X" style lift scissors
Right (curb) side hopper dump

Hydraulic System:

Pump: Dual tandem gear
Capacity: 22 gpm @ 2000 rpm
Reservoir: 40 gallons
Hydraulic Oil Filter: 10 micron
Oil Cooler: Electric remote mounted
Integral hydraulic pressure gauges

Water Spray System:

Tank Capacity: 200 gallons
Construction: Polyethylene
Pump: 3.6 gpm electric diaphragm
Spray Nozzles:

- 4 on front spray bar
- 2 on each gutter broom
- 4 on main broom

Fill Hose: 20' with NST coupler with anti-siphon air gap
Water Pump Prefilter: 80 mesh

Electrical System:

Alternator: 120 AMP Voltage: 12 volt
LED Lights: front & rear strobes; gutter brooms & rear-mounted working lights; license plate;
2 stop/turn/tail; & clearance lights
Backup alarm

Camera & Monitor Safety System:

7" Color monitor with right side gutter broom & rear backup color cameras

Instrumentation & Controls:

Sweeper function rocker switches
Elevator stall alarm & light
Auxiliary engine hour meter & tachometer
Electric throttle
Console night light

Sweeper Engine:

Make: Kubota V2403-M-T-E3 T4 Interim
Horsepower: 59 @ 2700 rpm
Type: in-line, four-cylinder turbo diesel

Paint:

Body: Standard white high-gloss urethane enamel
Undercarriage: Flat black enamel

Standard Accessories:

Auto pickup in reverse
Auto shutdown for high temperature/low pressure
Independent left & right gutter broom operation
36 gallon, common fuel tank
Operators, parts & maintenance manuals
Top mounted, front & back amber LED lights

Limited Warranty Policy:

The Starfire S-4c sweeper is guaranteed to be free from defects due to faulty materials and/or workmanship for a period of 12 months, or 1,000 hours (whichever occurs first). Liability is limited to replacement of defect parts at factory or authorized dealer. The standard warranty of the chassis manufacturer and auxiliary engine applies. Isuzu chassis includes extended 5-year/150,000 mile Isuzu drive-train warranty. *Please read full warranty statement for details and limitations.*

Available Options: (not included in base price)

Arrow board
Automatic lubrication systems
Left (driver-side) hopper dump
Bristle strips dirt-shoe brushes
Camera—hopper dump observation
Camera—hopper inside loading view
Camera lens washer per location
Epoxy hopper liner
Front mounted magnet
Hopper vibrator
Hydraulic system—high oil temperature warning
Hydraulic system—low oil level warning
Main broom motor guard
Main broom debris channeler
On-board high pressure spray wash-down system with hose reel; 50' of hose and wand
Reverse ultrasonic obstacle detection system
Strobe light protectors
Water pump; additional 3.6 gpm

The Starfire S-4c has built a reputation for rugged, reliability and superior sweeping performance. Let us build one for you. Call your dealer today to arrange for a demonstration.

Available on:

HGACBuy
THE SMART PURCHASING SOLUTION

GSA Schedule
Contract GS-30F-021AA

Sold and Supported Locally by:



The Right Sweepers to Match Your Needs

Whatever your sweeping challenge, Stewart-Amos has the right sweeper to match your needs. We offer a full line of *effectively simple* mechanical broom and regenerative air street sweepers.

STEWART-AMOS
Sweeper Co.

Harrisburg, PA USA
800.482.2302
stewart-amos.com

Specifications are subject to change without notice.
Copyright © Stewart-Amos Sweeper Co. / 2017